



LEISTUNGSERKLÄRUNG

DoP W0003

für fischer Power-Fast-Schrauben und fischer-Holzbauschrauben

DE

1. Eindeutiger Kenncode des Produkttyps: DoP W0003
2. Verwendungszweck(e): Selbstbohrende Schrauben zur Verwendung in Holzkonstruktionen, siehe Anhang, insbesondere die Anhänge 1, 2.
3. Hersteller: fischerwerke GmbH & Co. KG, Klaus-Fischer-Str. 1, 72178 Waldachtal, Deutschland
4. Bevollmächtigter: -
5. AVCP - System/e: 3
6. Europäisches Bewertungsdokument: EAD 130118-00-0603
Europäische Technische Bewertung: ETA-11/0027; 2019-01-02
Technische Bewertungsstelle: ETA-Danmark A/S
Notifizierte Stelle(n): 0769 Karlsruher Institut für Technologie (KIT)
7. Erklärte Leistung(en):
Mechanische Festigkeit und Standsicherheit (BWR 1), Sicherheit und Barrierefreiheit bei der Nutzung (BWR 4)
Abmessungen: Anhänge 13-32
Charakteristisches Fließmoment: Anhang 5
Biegewinkel: Anhang 1
Charakteristischer Ausziehparameter: Anhänge 5,6
Charakteristischer Kopfdurchziehparameter: Anhang 6
Charakteristische Zugfestigkeit: Anhang 3
Charakteristische Streckgrenze: Anhang 7
Charakteristische Torsionsfestigkeit: Anhang 3
Einschraubmoment: Anhang 3
Achsabstände, End- und Randabstände der Schrauben und Mindestdicke des Holzmaterials: Anhänge 10,11,39

Verschiebungsmodul für hauptsächlich axial belastete Schrauben: Anhang 8
Beständigkeit gegen Korrosion: Anhänge 1,2,9,10,13-32

Sicherheit im Brandfall (BWR 2)
Brandverhalten: Klasse (A1)
8. Angemessene Technische Dokumentation und/oder Spezifische Technische Dokumentation: -

Die Leistung des vorstehenden Produkts entspricht der erklärten Leistung/den erklärten Leistungen. Für die Erstellung der Leistungserklärung im Einklang mit der Verordnung (EU) Nr. 305/2011 ist allein der obengenannte Hersteller verantwortlich.

Unterzeichnet für den Hersteller und im Namen des Herstellers von:

Dr.-Ing. Oliver Geibig, Geschäftsführer Business Units & Engineering
Tumlingen, 2021-01-16

Jürgen Grün, Geschäftsführer Chemie & Qualität

Diese Leistungserklärung wurde in mehreren Sprachen erstellt. Für alle Streitigkeiten, die sich aus der Auslegung ergeben, ist die Fassung in englischer Sprache maßgeblich.

Der Anhang enthält freiwillige und ergänzende Informationen in englischer Sprache, die über die (sprachneutral festgelegten) gesetzlichen Anforderungen hinausgehen.

II BESONDERER TEIL DER EUROPÄISCHEN TECHNISCHEN BEWERTUNG

1 Beschreibung des Produkts und des Verwendungszwecks

Technische Beschreibung des Produkts

„fischer Power-Fast“-Schrauben und „fischer-Holzbauschrauben“ sind selbstbohrende Schrauben, die in Holzkonstruktionen verwendet werden. „fischer Power-Fast“-Schrauben haben ein Teilgewinde oder ein Vollgewinde, „fischer-Holzbauschrauben“ haben ebenfalls ein Teilgewinde oder ein Vollgewinde. Schrauben aus Kohlenstoffstahl-Draht werden mit einem Nenndurchmesser von 3,0 mm bis 12,0 mm gefertigt. Schrauben aus rostfreiem Stahldraht werden mit einem Nenndurchmesser von 3,0 mm bis 8,0 mm gefertigt. Die Materialspezifikation der Edelstahlschrauben ist bei der ETA-Danmark hinterlegt. Ist ein Korrosionsschutz erforderlich, so müssen Material bzw. Beschichtung mit den relevanten in Anhang A der EN 14592 angeführten Spezifikationen übereinstimmen.

Geometrie und Material

Der Nenndurchmesser (Gewindeaußendurchmesser), d , darf nicht kleiner als 3,0 mm und nicht größer als 12,0 mm sein. Die Gesamtlänge der Schrauben l_s darf nicht kürzer als 20 mm und nicht länger als 600 mm sein. Die sonstigen Maße sind in Anhang A1 bis Anhang A18 angegeben.

Das Verhältnis des Kerndurchmessers zum Gewindeaußendurchmesser d_1/d reicht von 0,59 bis 0,69.

Die Schrauben haben eine Mindestgewindelänge l_g von $4,0 \cdot d$ (d.h. $l_g \geq 4,0 \cdot d$).

Die Gewindesteigung p (Abstand zwischen zwei nebeneinander liegenden Gewindeflanken) reicht von $0,50 \cdot d$ bis $0,67 \cdot d$.

Bei einem Biegewinkel α von weniger als $(45/d^{0,7} + 20)$ Grad dürfen die Schrauben keine Risse aufweisen.

Die Materialspezifikation der Edelstahlschrauben ist bei der ETA-Danmark hinterlegt.

2 Beschreibung des bestimmungsgemäßen Gebrauchs laut geltender EAD

Die Schrauben sind für die Verwendung in tragenden Holzkonstruktionen zur Verbindung von Teilen aus Vollholz (Nadel- und Laubholz) sowie aus Brettschichtholz, Brettsperrholz, Furnierschichtholz,

ähnlichen verleimten Holzbauteilen, Holzwerkstoffplatten oder von Stahlteilen bestimmt.

Zudem können „fischer Power-Fast“-Schrauben mit einem Durchmesser von 6 mm, 8 mm, 10 mm und 12 mm auch zur Befestigung von Aufdachdämmsystemen auf Sparren und zur Befestigung von Wärmedämmung an vertikalen Fassaden verwendet werden.

Stahlbleche und Holzwerkstoffplatten dürfen, mit Ausnahme von Vollholz-, und Brettsperrholzplatten, Egger OSB Eurostrand 4 TOP, nur auf der Seite des Schraubenkopfes angebracht werden. Nachstehende Holzwerkstoffplatten können verwendet werden:

- Sperrholz gemäß EN 636 oder ETA
- Spanplatten gemäß EN 312 oder ETA
- Grobspanplatten des Typs OSB/3 und OSB/4 gemäß EN 300 oder ETA
- Faserplatten gemäß EN 622-2 und 622-3 oder ETA (Mindestrohddichte 650 kg/m^3)
- Zementgebundene Spanplatten gemäß ETA
- Vollholzplatten gemäß EN 13353 und EN 13986, sowie Brettsperrholz gemäß ETA
- Furnierschichtholz gemäß EN 14374 oder ETA
- Verarbeitete Holzwerkstoff-Produkte gemäß ETA, sofern diese Regelungen für die Verwendung von selbstbohrenden Schrauben enthält und die Vorgaben der für das verarbeitete Holzwerkstoff-Produkt ausgestellten ETA eingehalten sind.

Die Schrauben dürfen in Nadelholz mit oder ohne Vorbohren eingedreht werden, wobei der Bohrdurchmesser der Vorbohrung über die gesamte Länge des Gewindebereichs nicht größer als der Kerndurchmesser und im Bereich des glatten Schafts nicht größer als der Schaftdurchmesser sein darf. In Laubholz sind die Schrauben mit Vorbohren einzudrehen, wobei der Durchmesser der Vorbohrung einen angemessenen Durchmesser wie in Abschnitt 3.11 vorgegeben aufweisen muss.

Die Schrauben sind für Holzverbindungen vorgesehen, welche die Anforderungen an mechanische Beständigkeit, Stabilität und Gebrauchssicherheit im Sinne der grundlegenden Anforderungen 1 und 4 der Verordnung 305/2011 erfüllen.

Form und Maße der Unterlegscheiben sind in Anhang A19 vorgegeben. Die Unterlegscheiben müssen aus Stahl sein.

Die Bemessung der Verbindungen muss auf den charakteristischen Werten der Tragfähigkeit der Schrauben basieren. Die Tragfähigkeiten sind von den charakteristischen Werten gemäß Eurocode 5 oder einer entsprechenden nationalen Norm (z. B. DIN 1052:2008-12) abzuleiten. Hinsichtlich der Umweltbedingungen finden die auf der Baustelle geltenden, nationalen Rechtsvorschriften Anwendung.

Die Schrauben sind für die Verwendung in Verbindungen mit ruhender oder vorwiegend ruhender Belastung vorgesehen.

Zinkbeschichtete Schrauben sind für die Verwendung in Holzkonstruktionen unter trockenen Innenraumbedingungen wie in den Nutzungsklassen 1 und 2 der EN 1995-1-1:2008 (Eurocode 5) definiert, vorgesehen.

Aus Edelstahl gefertigte Schrauben erfüllen die Anforderungen des Eurocode 5 (EN 1995-1-1:2008) für die Verwendung in Konstruktionen, die gemäß Definition in Nutzungsklasse 3 feuchten Bedingungen ausgesetzt sind.

Der Anwendungsbereich der Schrauben hinsichtlich Korrosionsbeständigkeit ist nach den nationalen Vorschriften für Umweltbedingungen am Einbauort zu definieren.

Die Bestimmungen dieser Europäischen Technischen Bewertung beruhen auf der Annahme einer vorgesehenen Nutzungsdauer der Schrauben von 50 Jahren.

Die Angaben zur Nutzungsdauer können nicht als eine Garantie des Herstellers ausgelegt werden, sondern dienen lediglich als Hilfsmittel zur Auswahl der geeigneten Produkte im Hinblick auf die erwartete, wirtschaftlich vernünftige Nutzungsdauer des Bauwerks.

Leistung des Produkts und Verweise auf die Bewertungsverfahren

Merkmal	Beurteilung des Merkmals
3.1 Mechanische Beständigkeit und Stabilität*) (BWR1)	
Zugtragfähigkeit Schrauben aus Kohlenstoffstahl	Charakteristischer Wert $f_{tens,k}$: Schraube d = 3,0 mm: 2,7 kN Schraube d = 3,5 mm: 3,7 kN Schraube d = 4,0 mm: 4,8 kN Schraube d = 4,5 mm: 6,0 kN Schraube d = 5,0 mm: 7,5 kN Schraube d = 6,0 mm: 10,7 kN Schraube d = 8,0 mm: 19,1 kN Schraube d = 10,0 mm: 29,8 kN Schraube d = 12,0 mm: 32,7 kN
Schrauben aus Edelstahl	Schraube d = 3,0 mm: 1,6 kN Schraube d = 3,5 mm: 2,1 kN Schraube d = 4,0 mm: 2,8 kN Schraube d = 4,5 mm: 3,5 kN Schraube d = 5,0 mm: 4,3 kN Schraube d = 6,0 mm: 6,2 kN Schraube d = 8,0 mm: 13,0 kN
Einschraubmoment	Verhältnis des charakteristischen Werts des Bruchdrehmoments zum mittleren Einschraubmoment: $f_{tor,k} / R_{tor,mean} \geq 1,5$
Bruchdrehmoment Schrauben aus Kohlenstoffstahl	Charakteristischer Wert $f_{tor,k}$: Schraube d = 3,0 mm: 1,3 Nm Schraube d = 3,5 mm: 2,0 Nm Schraube d = 4,0 mm: 3,0 Nm Schraube d = 4,5 mm: 4,3 Nm Schraube d = 5,0 mm: 6,0 Nm Schraube d = 6,0 mm: 9,5 Nm Schraube d = 8,0 mm: 25,0 Nm Schraube d = 10,0 mm: 40,0 Nm Schraube d = 12,0 mm: 55,0 Nm
Schrauben aus Edelstahl	Schraube d = 3,0 mm: 0,9 Nm Schraube d = 3,5 mm: 1,3 Nm Schraube d = 4,0 mm: 1,9 Nm Schraube d = 4,5 mm: 2,6 Nm Schraube d = 5,0 mm: 3,7 Nm Schraube d = 6,0 mm: 6,5 Nm Schraube d = 8,0 mm: 16,0 Nm
3.2 Sicherheit im Brandfall (BWR2)	
Brandverhalten	Die Schrauben bestehen aus Stahl der Euroklasse A1 gemäß EN 13501-1 und Verordnung der Kommission 2016/364.

Merkmal	Beurteilung des Merkmals
3.3 Hygiene, Gesundheit und Umwelt (BWR3)	
Beeinflussung der Luftqualität	Das Produkt enthält keine der in TR 034 vom Oktober 2015 **) angegebenen gefährlichen Stoffe und setzt auch keine solchen frei.
3.7 Nachhaltige Nutzung natürlicher Ressourcen (BWR7)	Keine Leistung festgelegt
3.8 Allgemeine Aspekte der Gebrauchstauglichkeit des Produkts	Die Schrauben weisen bei der Verwendung in Holzkonstruktionen, bei denen Holztypen gemäß Eurocode 5 und den Vorgaben der Nutzungsklassen 1, 2 und 3 zum Einsatz kommen, eine zufriedenstellende Haltbarkeit und Gebrauchstauglichkeit auf.
Identifikation	Siehe Anhang A

*) Siehe zusätzliche Angaben in den Abschnitten 3.9-3.12.

**) Zusätzlich zu den in dieser Europäischen Technischen Bewertung enthaltenen Sonderbestimmungen über gefährliche Stoffe können die Produkte im Geltungsbereich dieser Bewertung weiteren Anforderungen unterliegen (z. B. umgesetzter europäischer Gesetzgebung und nationalen Rechts- und Verwaltungsvorschriften). Für eine Einhaltung der Vorschriften der Bauproduktrichtlinie müssen auch diese Anforderungen erfüllt sein, wenn und wo sie bestehen.

3.9 Mechanische Beständigkeit und Stabilität

Die Tragfähigkeiten der „fischer Power-Fast“-Schrauben und „fischer-Holzbauschrauben“ gelten ebenfalls für die in Abschnitt 1 genannten Holzwerkstoffe, wenn auch nachstehend nur der Begriff Holz verwendet wird.

Der charakteristische Wert der Quertragfähigkeit und der charakteristische Wert der axialen Ausziehtragfähigkeit der „fischer Power-Fast“-Schrauben und der „fischer-Holzbauschrauben“ sollten bei Konstruktionen gemäß Eurocode 5 oder einer entsprechenden nationalen Norm verwendet werden.

Die Eindringtiefe des Gewindeteils ab Schraubenspitze muss $l_{ef} \geq 4 \cdot d$, betragen, wobei d der Gewindeaußendurchmesser der Schraube ist. Zur Befestigung von Sparren muss die Eindringtiefe ab Schraubenspitze mindestens 40 mm, $l_{ef} \geq 40$ mm betragen.

Etwaige für die tragenden Bauteile geltende ETA sind gegebenenfalls zu berücksichtigen.

Etwaige für die Holzwerkstoffplatten geltende ETA sind gegebenenfalls zu berücksichtigen.

Tragfähigkeit rechtwinklig zur Schraubenachse

Der charakteristische Wert der Quertragfähigkeit der „fischer Power-Fast“-Schrauben und „fischer-Holzbauschrauben“ ist nach EN 1995-1-1:2008 (Eurocode 5) mit dem Gewindeaußendurchmesser d als Nenndurchmesser der Schraube zu berechnen. Die Wirkung des Seileinhangeffekts darf dabei berücksichtigt werden.

Der charakteristische Wert des Fließmoments ist wie folgt zu berechnen:

Schrauben aus Kohlenstoffstahl mit $3,0 \text{ mm} \leq d \leq 5,0 \text{ mm}$ und $12,0 \text{ mm}$:

$$M_{y,k} = 0,15 \cdot 500 \text{ (N/mm}^2\text{)} \cdot d^{2,6}$$

[Nmm]

Schrauben aus Kohlenstoffstahl mit $6,0 \text{ mm} \leq d \leq 10,0 \text{ mm}$:

$$M_{y,k} = 0,15 \cdot 600 \text{ (N/mm}^2\text{)} \cdot d^{2,6}$$

[Nmm]

Schrauben aus Edelstahl mit $3,0 \text{ mm} < d < 6,0 \text{ mm}$:

$$M_{y,k} = 0,15 \cdot 350 \text{ (N/mm}^2\text{)} \cdot d^{2,6}$$

[Nmm]

Schrauben aus Edelstahl mit $d = 8,0 \text{ mm}$:

$$M_{y,k} = 0,15 \cdot 400 \text{ (N/mm}^2\text{)} \cdot d^{2,6}$$

[Nmm]

Darin ist

d Gewindeaußendurchmesser [mm]

Die charakteristische Lochleibungsfestigkeit der Schrauben in nicht vorgebohrten Löchern folgt bei einem Winkel der Schraubenachse zur Faser von $0^\circ \leq \alpha \leq 90^\circ$ aus:

$$f_{h,k} = \frac{0,082 \cdot \rho_k \cdot d^{-0,3}}{2,5 \cdot \cos^2 \alpha + \sin^2 \alpha} \quad [\text{N/mm}^2]$$

und folgt dementsprechend für Schrauben in vorgebohrten Löchern aus:

$$f_{h,k} = \frac{0,082 \cdot \rho_k \cdot (1 - 0,01 \cdot d)}{2,5 \cdot \cos^2 \alpha + \sin^2 \alpha} \quad [\text{N/mm}^2]$$

Darin sind

ρ_k charakteristische Rohdichte [kg/m^3];

d Gewindeaußendurchmesser [mm];

α Winkel zwischen Schraubenachse und Faserrichtung.

Die Lochleibungsfestigkeit von parallel zur Plattenebene von in Brettsperrholz eingedrehten Schrauben ergibt sich, unabhängig vom Winkel zwischen Schraubenachse und Faserrichtung

$0^\circ \leq \alpha \leq 90^\circ$ zu:

$$f_{h,k} = 20 \cdot d^{-0,5} \quad [\text{N/mm}^2]$$

Darin ist

d Gewindeaußendurchmesser [mm]

Die Lochleibungsfestigkeit von in der Seitenfläche von Brettsperrholz eingedrehten Schrauben sollte wie bei Bauteilen aus Vollholz auf Basis der charakteristischen Rohdichte der äußeren Lage berücksichtigt werden. Soweit relevant, ist der Winkel zwischen Krafrichtung und Faserrichtung der äußeren Lage zu berücksichtigen.

Die Querkraft soll senkrecht zur Schraubenachse und parallel zur Seitenfläche des Bauteils aus Brettsperrholz wirken.

Axialer Auszieh Widerstand

Der charakteristische Wert des axialen Auszieh Widerstandes der „fischer Power-Fast“-Schrauben und der „fischer-Holzbauschrauben“ in Bauteilen aus Vollholz (Nadelholz sowie Esche, Buche oder Eiche), Brettchichtholz (Nadelholz und Laubholz, Esche, Buche oder Eiche) oder Furnierschichtholz (Nadelholz oder Laubholz Buche) oder Bauteilen aus Brettsperrholz bei einem Winkel von $0^\circ \leq \alpha \leq 90^\circ$ zur Faserrichtung oder in Egger Eurostrand OSB 4 TOP in einem Winkel von $\alpha=90^\circ$ zur Seitenfläche ist nach folgender Gleichung zu berechnen:

$$F_{ax,\alpha,Rk} = n_{ef} \cdot k_{ax} \cdot f_{ax,k} \cdot d \cdot l_{ef} \cdot \left(\frac{\rho_k}{350} \right)^{0,8} \quad [N]$$

Darin sind

$F_{ax,\alpha,Rk}$ Charakteristischer Auszieh Widerstand der Verbindung unter einem Winkel α zur Faserrichtung [N]

n_{ef} Effektive Anzahl der Schrauben gemäß EN 1995-1-1

Geneigte Schrauben: $n_{ef} = \max \{ n^{0,9}; 0,9 \cdot n \}$

k_{ax} Faktor zur Berücksichtigung des Winkels α zwischen Schraubenachse und Faserrichtung
 $k_{ax} = 1,0$ for $45^\circ \leq \alpha < 90^\circ$

$k_{ax} = 0,3 + \frac{0,7 \cdot \alpha}{45}$ for $0^\circ \leq \alpha < 45^\circ$

$f_{ax,k}$ Charakteristischer Ausziehparameter für Massivholz [N/mm²] Schrauben $d = 3,0$ mm:

$f_{ax,k} = 13,8$ N/mm²

Schrauben $d = 3,5$ mm: $f_{ax,k} = 13,4$ N/mm²

Schrauben $d = 4,0$ mm: $f_{ax,k} = 13,0$ N/mm²

Schrauben $d = 4,5$ mm: $f_{ax,k} = 12,6$ N/mm²

Schrauben $d = 5,0$ mm: $f_{ax,k} = 12,2$ N/mm²

Schrauben $d = 6,0$ mm: $f_{ax,k} = 11,6$ N/mm²

Schrauben $d \geq 8,0$ mm: $f_{ax,k} = 10,0$ N/mm²

für Egger Eurostrand OSB 4 TOP mit einer Mindestdicke $t=12$ mm und Schrauben

$5,0\text{mm} \leq d \leq 10,0\text{mm}$: $f_{ax,k} = 10,0$ N/mm²

d Gewindeaußendurchmesser [mm]

l_{ef} Eindringtiefe des Gewindeteils ab Schraubenspitze gemäß EN 1995-1-1:2008 [mm]

α Winkel zwischen Faserrichtung und Schraubenachse ($^\circ$)

ρ_k Charakteristische Rohdichte [kg/m³], für Laubholz darf die angesetzte charakteristische Rohdichte 730 kg/m³ nicht überschreiten

Bei Schrauben, angeordnet unter einem Winkel von weniger als 90° zwischen Schraubenachse und Faserrichtung, beträgt die Mindesteindringtiefe des Gewindeteils:

$$l_{ef} \geq \min (4 \cdot d / \sin \alpha ; 20 \cdot d)$$

Bei Schrauben, die bei Bauteilen aus Brettsperrholz in mehr als eine Schicht eindringen, dürfen die verschiedenen Schichten entsprechend berücksichtigt werden.

Der Auszieh Widerstand wird durch den Kopfdurchzieh Widerstand der Schraube bzw. der Unterlegscheibe und der Zugtragfähigkeit der Schraube begrenzt.

Bei axial beanspruchten Schrauben unter Zugbelastung und einer äußeren Kraft parallel zur Schraubenachse gilt die in EN 1995-1-1, 8.7.2 (8) aufgeführte Regel.

Bei schräg angeordneten Schrauben in Holz-Holz- oder Stahl-Holz-Scherverbindungen, in denen die Schrauben in einem Winkel von $30^\circ \leq \alpha \leq 60^\circ$ zwischen Scherfläche und Schraubenachse angeordnet werden, ist die effektiv wirksame Zahl der Schrauben n_{ef} folgendermaßen zu bestimmen:

Für eine Reihe mit n parallel zur Lasteinwirkung angeordneten Schrauben ist die Tragfähigkeit unter Einbeziehung der effektiv wirksamen Anzahl der Befestigungselemente, n_{ef} , zu ermitteln, wobei

$$n_{ef} = \max \{ n^{0,9}; 0,9 \cdot n \}$$

und n die Anzahl der in einer Reihe geneigt angeordneten Schrauben beschreibt. Bei gekreuzt angeordneten Schraubenpaaren in Holz-Holz-Konstruktionen ist n die Anzahl der in einer Reihe gekreuzt angeordneten Schraubenpaare.

Bitte beachten:

Für Schrauben als Verbindung in nachgiebig verbundenen Balken oder Stützen bzw. bei der Befestigung von Aufdachdämmsystemen gilt $n_{ef} = n$

Kopfdurchzieh Widerstand

Der charakteristische Durchzieh Widerstand der „fischer Power-Fast“-Schrauben und der „fischer-Holzbauschrauben“ ist gemäß EN 1995-1-1:2008 nach folgender Gleichung zu ermitteln:

$$F_{ax,\alpha,Rk} = n_{ef} \cdot f_{head,k} \cdot d_h^2 \cdot \left(\frac{\rho_k}{350} \right)^{0,8} \quad [N]$$

Darin sind

$F_{ax,\alpha,Rk}$ der charakteristische Durchzieh Widerstand der Verbindung bei einem Winkel $\alpha \geq 30^\circ$ zur Faserrichtung [N]

n_{ef} die effektiv wirksame Anzahl der Schrauben gemäß EN 1995-1-1

Geneigte Schrauben: $n_{ef} = \max \{ n^{0,9}; 0,9 \cdot n \}$

(siehe unter axialer Auszieh Widerstand)

$f_{head,k}$ der charakteristische Durchziehparameter [N/mm²]

d_h der Schraubenkopfdurchmesser [mm]

ρ_k die charakteristische Rohdichte [kg/m³], für Holzwerkstoffplatten $\rho_k = 380$ kg/m³

Charakteristischer Durchziehparameter für Schrauben mit einem Schraubendurchmesser ≤ 21 mm in Verbindungen mit Holz und Holzwerkstoffen mit einer Dicke von über 20 mm:

$$f_{\text{head},k} = 12 \text{ N/mm}^2$$

Charakteristischer Durchziehparameter für Schrauben mit einem Schraubendurchmesser $21 \text{ mm} < d_h \leq 35$ mm in Verbindungen mit Holz und Holzwerkstoffen mit einer Dicke von über 20 mm:

$$f_{\text{head},k} = 10 \text{ N/mm}^2$$

Charakteristischer Durchziehparameter für Schrauben in Verbindungen mit Holzwerkstoffen mit einer Stärke zwischen 12 mm und 20 mm:

$$f_{\text{head},k} = 8 \text{ N/mm}^2$$

Schrauben in Verbindungen mit Holzwerkstoffen mit einer Dicke von unter 12 mm (Mindestdicke für Holzwerkstoffe beträgt $1,2 \cdot d$, wobei d den Gewindeaußendurchmesser beschreibt):

$$f_{\text{head},k} = 8 \text{ N/mm}^2$$

begrenzt auf $F_{\text{ax},\alpha,\text{Rk}} = 400 \text{ N}$

Der Schraubendurchmesser d_h muss größer sein als $1,8 d_s$, wobei d_s dem glatten Schraubenschaft bzw. dem Drahtdurchmesser entspricht. Ansonsten beträgt der charakteristische Durchziehparameter $F_{\text{ax},\alpha,\text{Rk}} = 0$.

Außendurchmesser der Unterlegscheiben von $d_h > 35$ mm dürfen nicht berücksichtigt werden.

Die Mindeststärken der Holzwerkstoffplatten gemäß Abschnitt 3.9 sind einzuhalten.

In Stahl-Holz-Verbindungen ist der Durchziehparameter nicht maßgebend.

Zugtragfähigkeit

Der charakteristische Wert der Zugtragfähigkeit $f_{\text{tens},k}$ der „fischer Power-Fast“-Schrauben und der „fischer-Holzbauschrauben“ beträgt:

Schrauben aus Kohlenstoffstahl:

Schraube d = 3,0 mm:	2,7 kN
Schraube d = 3,5 mm:	3,7 kN
Schraube d = 4,0 mm:	4,3 kN
Schraube d = 4,5 mm:	5,5 kN
Schraube d = 5,0 mm:	6,8 kN
Schraube d = 6,0 mm:	10,7 kN
Schraube d = 8,0 mm:	19,1 kN
Schraube d = 10,0 mm:	29,8 kN
Schraube d = 12,0 mm:	32,7 kN

Schrauben aus Edelstahl:

Schraube d = 3,0 mm:	1,6 kN
Schraube d = 3,5 mm:	2,1 kN

Schraube d = 4,0 mm: 2,8 kN

Schraube d = 4,5 mm: 3,5 kN

Schraube d = 5,0 mm: 4,3 kN

Schraube d = 6,0 mm: 6,2 kN

Schraube d = 8,0 mm: 13,0 kN

Bei Schrauben, die in Verbindungen mit Stahlplatten verwendet werden, muss die Abreißfestigkeit des Schraubenkopfes größer sein als die Zugfestigkeit der Schraube.

Beanspruchung auf Druck

Die charakteristische Tragfähigkeit auf Druck $F_{\text{ax},\text{Rk}}$ von „fischer Power-Fast“-Schrauben, deren Kopf lt. Anhang D zwischen zwei Aluminium- Stahl- oder Edelstahlplatten eingespannt ist, und deren Gewinde vollständig und senkrecht zur Faserrichtung des Holzes eingeschraubt ist, wird wie folgt ermittelt:

$$F_{\text{ax},\text{Rk}} = \min \left\{ f_{\text{ax},k} \cdot d \cdot \ell_{\text{ef}} \cdot \left(\frac{P_k}{350} \right)^{0,8} ; \kappa_c \cdot N_{\text{pl},k} \right\} \quad [\text{N}]$$

hierin gilt

$$\kappa_c = \begin{cases} 1 & \text{für } \bar{\lambda}_k \leq 0,2 \\ \frac{1}{k + \sqrt{k^2 - \bar{\lambda}_k^2}} & \text{für } \bar{\lambda}_k > 0,2 \end{cases}$$

$$k = 0,5 \cdot \left[1 + 0,49 \cdot (\bar{\lambda}_k - 0,2) + \bar{\lambda}_k^2 \right]$$

Der bezogene Schlankheitsgrad wird wie folgt ermittelt:

$$\bar{\lambda}_k = \sqrt{\frac{N_{\text{pl},k}}{N_{\text{ki},k}}}$$

wobei

$$N_{\text{pl},k} = \pi \cdot \frac{d_s^2}{4} \cdot f_{y,k} \quad [\text{N}]$$

der charakteristische Wert der plastischen Normalkraft-Tragfähigkeit des glatten Schaftbereichs ist.

$$N_{\text{ki},k} = \frac{\pi^2 \cdot EI_s}{\ell_{\text{ef}}^2} \quad [\text{N}]$$

ist die charakteristische ideal-elastische Knicklast.

Die charakteristische Streckgrenze für Schrauben aus Kohlenstoffstahl beträgt:

$$f_{y,k} = 1000 \quad [\text{N/mm}^2]$$

Die charakteristische Streckgrenze für Schrauben aus Edelstahlstahl beträgt:

$$f_{y,k} = 500 \quad [\text{N/mm}^2]$$

Der Elastizitätsmodul für Schrauben aus Kohlenstoffstahl beträgt:

$$E_s = 210000 \quad [\text{N/mm}^2]$$

Der Elastizitätsmodul für Schrauben aus Edelstahl beträgt:

$$E_s = 160000 \quad [\text{N/mm}^2]$$

Flächenträgheitsmoment:

$$I_s = \frac{\pi}{64} \cdot d_s^4 \quad [\text{mm}^4]$$

d_s = glatter Schaftdurchmesser [mm]

$\ell_{ef} = 0,7 \cdot \ell$ Knicklänge [mm]

ℓ = freie Schraubenlänge, entspricht dem aus dem Holzbauteil herausstehenden Teil der Schraube inklusive Schraubenkopf [mm]

Hinweis: Bei der Bestimmung des Bemessungswertes für die Tragfähigkeit auf Druckbeanspruchung muss beachtet werden, dass $f_{ax,d}$ mit k_{mod} und γ_M für Holz gemäß EN1995 zu ermitteln ist, während $N_{pl,d}$ mit $\gamma_{M,1}$ für Ausknicken des Stahls nach EN 1993 berechnet wird.

Schrauben mit kombinierter Quer- und Zugbeanspruchung

Bei Verschraubungen, die einer kombinierten axialen und Querbeanspruchung ausgesetzt sind, muss die folgende Bedingung erfüllt sein:

$$\left(\frac{F_{ax,Ed}}{F_{ax,Rd}} \right)^2 + \left(\frac{F_{la,Ed}}{F_{la,Rd}} \right)^2 \leq 1$$

Darin sind

$F_{ax,Ed}$ Bemessungswert der einwirkenden Last in

Achsrichtung der Schraube

$F_{la,Ed}$ Bemessungswert der einwirkenden Last rechtwinklig zur Schraubenachse

$F_{ax,Rd}$ Bemessungswert der Zugtragfähigkeit der

Schraube

$F_{la,Rd}$ Bemessungswert der Quertragfähigkeit der Schraube

Verschiebungsmodul

Der Verschiebungsmodul K_{ser} des Gewindeteils einer Schraube beträgt für den Grenzzustand der Gebrauchstauglichkeit unabhängig vom Winkel zur Faserrichtung:

$$C = K_{ser} = 780 \cdot d^{0,2} \cdot \ell_{ef}^{0,4} \quad [\text{N/mm}]$$

Darin sind

d Gewindeaußendurchmesser [mm]

ℓ_{ef} Eindringtiefe in das Holzbauteil [mm]

Befestigung von Aufdachdämmsystemen

„fischer Power-Fast“-Schrauben und „fischer-Holzbauschrauben“ mit einem Gewindeaußendurchmesser von $d = 6$ mm, 8 mm, 10 mm und 12 mm können für die Befestigung von Aufdachdämmsystemen verwendet werden.

Die Dämmstoffdicke darf bis zu 400 mm betragen. Die Aufdachdämmung ist auf Sparren aus Vollholz oder Brettschichtholz oder Bauteilen aus Brettsperrholz anzubringen und mittels parallel zu den Sparren angeordneter Konterlatten oder auf der Dämmschicht angebrachter Holzwerkstoffplatten zu befestigen. Dies gilt sinngemäß auch für die Dämmung vertikaler Fassaden.

Die Schrauben sind ohne Vorbohren in einem Arbeitsgang durch die Konterlatten oder -platten und den Dämmstoff in die Sparren einzuschrauben.

Der Winkel α zwischen der Schraubenachse und der Faserrichtung der Sparren sollte zwischen 30° und 90° betragen.

Die Latten müssen aus Vollholz (Nadelholz) gemäß EN 338:2003-04 bestehen. Die Mindestdicke der Latten beträgt 80 mm, die Mindestbreite 100 mm für Schrauben mit einem Gewindeaußendurchmesser $d = 12$ mm. Die Mindestdicke der Latten beträgt 40 mm, die Mindestbreite 60 mm für Schrauben mit einem Gewindeaußendurchmesser $d = 10$ mm. Für Schrauben mit einem Gewindeaußendurchmesser $d = 6$ mm und 8 mm beträgt die Mindestdicke der Latten 30 mm und die Mindestbreite 50 mm.

Als Alternative zu den Latten können, jeweils mit einer Mindestdicke von 20 mm, auch Sperrholzplatten gemäß EN 636, Spanplatten gemäß EN 312, Grobspanplatten des Typs OSB/3 und OSB/4 gemäß EN 300 oder ETA und Vollholzplatten gemäß EN 13353 verwendet werden.

Die Sparren müssen aus Vollholz (Nadelholz) gemäß EN 338, Brettschichtholz gemäß EN 14081, Brettsperrholz, Furnierschichtholz gemäß EN 14374 oder ETA oder ähnlichen verleimten Holzbauteilen gemäß ETA bestehen und eine Mindestbreite von 60 mm aufweisen.

Der Dämmstoff muss einer ETA entsprechen.

Der Dämmstoff muss eine Druckspannung von mindestens $\sigma_{10\%} = 0,05$ N/mm² bei 10 % Stauchung gemäß EN 826:1996-05 aufweisen.

Die Befestigung des Dämmstoffs und der Konterlatten bzw. Platten kann anhand des in Anhang B dargestellten Statik-Modells rechnerisch erfasst werden. Die Latten bzw. Platten müssen eine ausreichende Festigkeit und Steifigkeit aufweisen. Der maximale Druck zwischen

Latten bzw. Platten und Dämmstoff darf $1,1 \cdot \sigma_{10\%}$ nicht übersteigen.

Der charakteristische Wert der axialen Ausziehtragfähigkeit der Schrauben bei Aufsparren- oder Fassadendämmung errechnet sich wie folgt:

$$F_{ax,\alpha,Rk} = \min \left\{ \begin{array}{l} k_{ax} * f_{ax,k} * d * l_{ef} * k_1 * k_2 * \left(\frac{\rho_k}{350}\right)^{0,8} \\ f_{head,k} * d_h^2 * \left(\frac{\rho_k}{350}\right)^{0,8} \\ f_{tens,k} \end{array} \right. \quad [N]$$

Darin sind

$F_{ax,\alpha,Rk}$ Charakteristischer Auszieh Widerstand der Verbindung bei einem Winkel α zur Faserrichtung [N]

k_{ax} Faktor zur Berücksichtigung des Winkels zwischen Schraubenachse und Faserrichtung
 $k_{ax} = 1,0$ for $45^\circ \leq \alpha < 90^\circ$

$$k_{ax} = 0,3 + \frac{0,7 \cdot \alpha}{45} \quad \text{for } 0^\circ \leq \alpha < 45^\circ$$

$f_{ax,k}$ Charakteristischer Ausziehparameter [N/mm²]

d Gewindeaußendurchmesser [mm]

l_{ef} Eindringtiefe des Gewindeteils ab Schraubenspitze gemäß EN 1995-1-1:2008 [mm]

α Winkel zwischen Faserrichtung und Schraubenachse ($\alpha \geq 30^\circ$)

$$k_1 = \min \{1; 220/t_{HI}\}$$

$$k_2 = \min \{1; \sigma_{10\%}/0,12\}$$

t_{HI} Dämmstoffdicke [mm]

$\sigma_{10\%}$ Druckspannung des Dämmstoffs bei 10 % Stauchung [N/mm²]
 $\sigma_{10\%} \geq 0,05$ N/mm²

$f_{head,k}$ Charakteristischer Durchziehparameter [N/mm²]

d_h Außendurchmesser des Schraubenkopfes [mm]

ρ_k Charakteristische Rohdichte [kg/m³]

$f_{tens,k}$ Charakteristische Zugtragfähigkeit der Schraube [N]

Reibungskräfte sind bei der Ermittlung des charakteristischen Werts des Auszieh Widerstands der Schrauben nicht zu berücksichtigen.

Die Verankerung gegen Windsogkräfte sowie die Biegespannungen in den Konterlatten bzw. Platten sind bei der Bemessung zu berücksichtigen. Falls erforderlich können zusätzliche Schrauben senkrecht zur Faserrichtung der Sparren (Winkel $\alpha = 90^\circ$) eingeschraubt werden.

Zur Verankerung der Aufsparrendämmung sind die Schrauben gemäß Anhang B anzuordnen.

Der Schraubenabstand darf maximal $e_s = 1,75$ m betragen.

3.10 Aspekte betreffend der Leistungsbeständigkeit des Produkts

3.10.1 Korrosionsschutz in Nutzungsklasse 1, 2 und 3.

„fischer Power-Fast“-Schrauben und „fischer-Holzbauschrauben“ werden aus Kohlenstoffstahl draht hergestellt. Aus Kohlenstoffstahl hergestellte Schrauben sind galvanisch verzinkt und gelb oder blau chromatiert.

Die mittlere Dicke der Zinkschicht beträgt 5 μ m.

Angaben über die Güte der Schrauben aus Edelstahl sind bei der ETA-Danmark hinterlegt.

3.11 Allgemeine Aspekte zum Verwendungszweck des Produkts

Diese Schrauben werden gemäß den Bestimmungen dieser Europäischen Technischen Bewertung unter Anwendung des Herstellungsverfahrens hergestellt, welches in der technischen Dokumentation hinterlegt ist.

Der Einbau hat gemäß Eurocode 5 oder einer entsprechenden nationalen Norm zu erfolgen, es sei denn, nachstehend werden andere Festlegungen getroffen.

Die Einbauanleitungen der Firma fischerwerke GmbH & Co. KG sollten berücksichtigt werden.

Die Schrauben sind in tragenden Holzkonstruktionen zur Verbindung von Teilen aus Vollholz (Nadel- und Laubholz), Brettschichtholz (Nadel- und Laubholz), Brettsperrholz (Minstdurchmesser $d=6,0$ mm, Nadel- und Laubholz), Furnierschichtholz (Nadel- und Laubholz) sowie ähnlich verleimten Holzbauteilen (Nadel- und Laubholz), Holzwerkstoffplatten und Stahlteilen bestimmt.

Die Schrauben können in tragenden Holzkonstruktionen zur Verbindung von Bauteilen gemäß einer etwaigen ETA des Bauteils verwendet werden, sofern gemäß der ETA des betreffenden Bauteils der Anbau an tragende Holzkonstruktionen mit Schrauben gemäß ETA zulässig ist.

Zudem können die Schrauben mit Durchmesser von 6 mm bis 12 mm zur Befestigung von Aufdach-Dämmsystemen auf Sparren oder zur Befestigung von Wärmedämmung an vertikalen Fassaden eingesetzt werden.

Bei Verbindungen in tragenden Holzkonstruktionen sind jeweils mindestens zwei Schrauben zu verwenden. Eine einzelne Schraube kann für tragenden Verbindungen verwendet werden, wenn die Eindringtiefe der Schraube einschließlich des glatten Schaftteils mindestens $20 \cdot d$ beträgt und die Schraube nur axial belastet wird. In

diesem Fall ist die Tragfähigkeit der einzelnen Schraube um 50% zu reduzieren.

Eine einzelne Schraube pro Verbindung kann auch verwendet werden, wenn das Bauteil mit mindestens zwei Schrauben angeschlossen ist und die Schrauben zur Befestigung von Schalungen, Latten (Trag- und Konterlatten) und Windrispen oder zur Befestigung von Sparren, Pfetten und dergleichen auf Bindern und Rähmen sowie von Querriegeln an Rahmenhölzern verwendet wird.

Die Mindesteindringtiefe in Bauteile aus Vollholz, Brettschichtholz oder Brettsperrholz beträgt $4 \cdot d$.

Holzwerkstoffplatten - ausgenommen Egger Eurostrand OSB 4 TOP - und Stahlbleche sollten nur auf der Seite des Schraubenkopfes angeordnet werden.

Holzwerkstoffplatten sollten eine Dicke von mindestens $1,2 \cdot d$ aufweisen. Zudem sollten bei folgenden Holzwerkstoffen die jeweiligen Mindestdicken beachtet werden:

- Sperrholz, Faserplatten: 6 mm
- Spanplatten, OSB-Platten, zementgebundene Spanplatten: 8 mm
- Vollholzplatten: 12 mm

Für Bauteile nach ETA sind die Bedingungen der jeweils einschlägigen ETA zu berücksichtigen.

Werden Schrauben mit einem Gewindeaußendurchmesser von $d \geq 8$ mm in tragenden Holzkonstruktionen verwendet, so müssen das Vollholz, Brettschichtholz, Furnierschichtholz und ähnlich verleimte Bauteile aus Fichten-, Kiefern- oder Tannenholz bestehen. Dies gilt nicht für das Einschrauben in vorgebohrte Löcher.

Der Winkel zwischen der Schraubenachse und der Faserrichtung muss mindestens $\alpha = 0^\circ$ betragen.

Schrauben dürfen mit oder ohne Vorbohren in Nadelholz eingedreht werden. Die Schrauben sind nach Vorbohren in Laubholz mit einer maximalen Rohdichte von 730 kg/m^3 einzudrehen.

Die Durchmesser der Vorbohrung betragen:

Gewindeaußendurchmesser	Bohrlochdurchmesser	
	Nadelholz	Laubholz
4,0	2,5	3,0
4,5	2,5	3,0
5,0	3,0	3,0
6,0	4,0	4,0
8,0	5,0	6,0
10,0	6,0	7,0

12,0	7,0	8,0
------	-----	-----

Bei Stahlteilen sind die Löcher mit einem angemessenen Durchmesser vorzubohren.

Für das Eindrehen der Schrauben ist ausschließlich das von der fischerwerke GmbH & Co. KG benannte Werkzeug zu verwenden.

In Verbindungen mit Senkkopfschrauben gemäß Anhang A1, A5, A6, A7, A11, A13 und A17 muss der Schraubenkopf bündig mit der Oberfläche des Anbauteils abschließen. Ein tieferes Versenken ist nicht zulässig.

Senkkopfschrauben aus Kohlenstoff- und Edelstahl nach Anhang A1, A2, A5, A6, A7, A11, A13, A14 und A17 können zusammen mit Unterlegscheiben gemäß Anhang A19 verwendet werden. Unterlegscheiben nach EN ISO 7094 können zusammen mit Unterlegscheiben nach Anhang A19 verwendet werden.

Schrauben nach Anhang A3, A4, A8, A9, A10, A12, A15, A16 und A18 können zusammen mit Unterlegscheiben nach EN ISO 7094 verwendet werden.

Unterlegscheiben aus Kohlenstoffstahl sollten zusammen mit Schrauben aus Kohlenstoffstahl, Unterlegscheiben aus Edelstahl zusammen mit Edelstahlschrauben verwendet werden. Die Unterlegscheiben müssen vollflächig anliegen.

Für Holzbauteile sind die in EN 1995-1-1:2008 (Eurocode 5) in Absatz 8.3.1.2 und Tabelle 8.2 angegebenen Mindeststrand- und Mindestachsabstände für Schrauben in vorgebohrten Löchern wie bei Nägeln in vorgebohrten Löchern einzuhalten. Dabei ist der Gewindeaußendurchmesser d anzusetzen.

EN 1995-1-1:2008 (Eurocode 5) gibt in Abschnitt 8.3.1.2 sowie in Tabelle 8.2 jeweils Mindestabstände für Schrauben ohne Vorbohren wie für Nägel ohne Vorbohren an.

Alternativ können die Mindeststrand- und Achsabstände von ausschließlich axial beanspruchten "fischer Power-Fast"-Schrauben in nicht vorgebohrten Bauteilen aus Vollholz (Nadel- und Laubholz), Brettschichtholz oder ähnlichen verleimten Holzbauteilen (Nadel- und Laubholz) mit einer Mindestdicke $t = 12 \cdot d$ und einer Mindestbreite von $8 \cdot d$ oder 60 mm (es gilt der jeweils höhere Wert) wie folgt ermittelt werden:

Achsabstand a_1 parallel zur Faserrichtung $a_1 = 5 \cdot d$
 Achsabstand a_2 senkrecht zur Faserrichtung $a_2 = 5 \cdot d$
 Abstand $a_{3,c}$ vom Schwerpunkt des im Holz eingedrehten Schraubenteils zum Hirnholzende $a_{3,c} = 9 \cdot d$
 Abstand $a_{4,c}$ vom Schwerpunkt des im Holz eingedrehten Schraubenteils

zum seitlichen Rand $a_{4,c} = 4 \cdot d$
 Der Achsabstand a_2 senkrecht zur Faserrichtung kann von $5 \cdot d$ auf $2,5 \cdot d$ verringert werden, sofern die Bedingung $a_1 \cdot a_2 \geq 25 \cdot d^2$ erfüllt ist.

Bei Bauteilen aus Douglasie sind die Mindeststrand- und Achsabstände parallel zur Faserrichtung um 50 % zu vergrößern.

Der Mindestabstand zum beanspruchten oder unbeanspruchten Hirnholzende muss bei nicht vorgebohrten Löchern und Schrauben mit einem Gewindeaußendurchmesser von $d > 8$ mm sowie einer Holzdicke $t < 5 \cdot d$ mindestens $15 \cdot d$ betragen.

Der Mindestabstand zum unbeanspruchten Rand senkrecht zur Faserrichtung kann auch bei einer Holzdicke $t < 5 \cdot d$ auf $3 \cdot d$ verringert werden, sofern der Abstand der Schrauben in Faserrichtung und zum Hirnholzende mindestens $25 \cdot d$ beträgt.

Soweit in der technischen Spezifikation (ETA oder hEN) von Brettsperrholz keine anderen Vorgaben enthalten sind, lassen sich für Schrauben, die in die Seitenfläche von Bauteilen aus Brettsperrholz mit einer Mindestdicke $t = 10 \cdot d$ eingeschraubt werden, jeweils folgende Werte für die Mindeststrand- und Achsabstände (vgl. Anhang C) ermitteln:

Achsabstand a_1 parallel zur Faser	$a_1 = 4 \cdot d$
Achsabstand a_2 senkrecht zur Faser	$a_2 = 2,5 \cdot d$
Abstand $a_{3,c}$ vom Schwerpunkt des im Holz eingedrehten Schraubenteils zum unbeanspruchten Hirnholzende der Decklage	$a_{3,c} = 6 \cdot d$
Abstand $a_{3,t}$ vom Schwerpunkt des im Holz eingedrehten Schraubenteils zum beanspruchten Hirnholzende der Decklage	$a_{3,t} = 6 \cdot d$
Abstand $a_{4,c}$ vom Schwerpunkt des im Holz eingedrehten Schraubenteils zur unbeanspruchten Schmalfläche	$a_{4,c} = 2,5 \cdot d$
Abstand $a_{4,t}$ vom Schwerpunkt des im Holz eingedrehten Schraubenteils zur beanspruchten Schmalfläche	$a_{4,t} = 6 \cdot d$

Soweit die technische Spezifikation (ETA oder hEN) für Brettsperrholz nichts anderes vorgibt, sind die Mindeststrand- und Mindestachsabstände von in der Schmalfläche von Brettsperrholzteilen mit einer Mindestdicke von $t = 10 \cdot d$ und mit einer Mindesteindringtiefe rechtwinklig zur Schmalfläche von $10 \cdot d$ eingedrehten Schrauben wie folgt zu ermitteln (siehe Anhang C):

Achsabstand a_1 parallel zur Seitenfläche des Brettsperrholzes	$a_1 = 10 \cdot d$
Achsabstand a_2 senkrecht zur Seitenfläche	

des Brettsperrholzes	$a_2 = 4 \cdot d$
Abstand $a_{3,c}$ vom Schwerpunkt des im Holz eingedrehten Schraubenteils zur unbeanspruchten Schmalfläche	$a_{3,c} = 7 \cdot d$
Abstand $a_{3,t}$ vom Schwerpunkt des im Holz eingedrehten Schraubenteils bis zur beanspruchten Schmalfläche	$a_{3,t} = 12 \cdot d$
Abstand $a_{4,c}$ vom Schwerpunkt des im Holz eingedrehten Schraubenteils zur unbeanspruchten Seitenfläche	$a_{4,c} = 3 \cdot d$
Abstand $a_{4,t}$ vom Schwerpunkt des im Holz eingedrehten Schraubenteils zur beanspruchten Seitenfläche	$a_{4,t} = 6 \cdot d$

Bei gekreuzt angeordneten Schraubenpaaren beträgt der Mindestachsabstand der gekreuzten Schrauben $1,5 \cdot d$.

Die Mindestdicke der Holzbauteile beträgt $t = 24$ mm für Schrauben mit einem Gewindeaußendurchmesser $d < 8$ mm, $t = 30$ mm für Schrauben mit einem Gewindeaußendurchmesser $d = 8$ mm, $t = 40$ mm für Schrauben mit einem Gewindeaußendurchmesser $d = 10$ mm und $t = 80$ mm für Schrauben mit einem Gewindeaußendurchmesser $d = 12$ mm.

4 Bescheinigung und Überprüfung der Leistungsbeständigkeit (AVCP)

4.1 AVCP-System

Gemäß Entscheidung 97/176/EG der Europäischen Kommission ist das System zur Bewertung und Überprüfung der Leistungsbeständigkeit (siehe Anhang V der Verordnung (EU) Nr. 305/2011) 3.

Schraubengrößen und Material

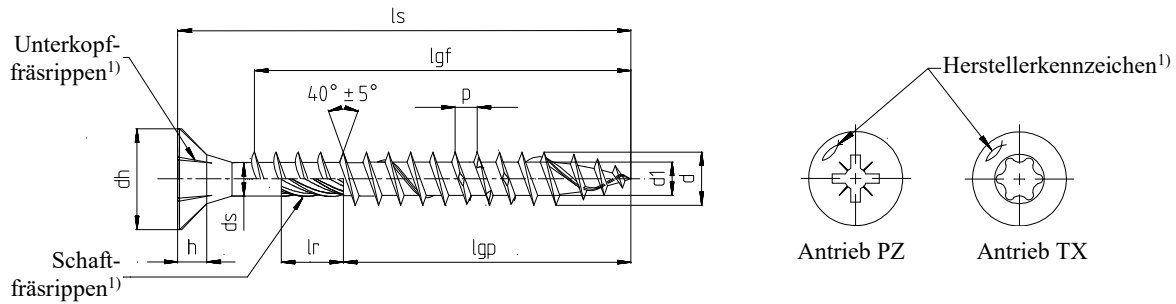

¹⁾ optional

Power-Fast selbstbohrende Schraube - Senkkopfschraube mit Voll- oder Teilgewinde

<ul style="list-style-type: none"> ▪ Kohlenstoffstahl ▪ Mögliche Oberflächenbehandlungen: galvanisch verzinkt - gelb oder blau, galvanisch verzinkt - blau $\geq 12\mu\text{m}$, Bonuszink, brüniert, vernickelt, vermessingt 																
 Nenndurchmesser		3,0	3,5	4,0	4,5	5,0	6,0									
d	Außendurchmesser	3,00	3,50	4,00	4,50	5,00	6,00									
	Zul. Abweichung	$\pm 0,30$														
d _i	Kerndurchmesser	2,00	2,20	2,50	2,70	3,00	4,00									
	Zul. Abweichung	$-0,25 / +0,10$				$\pm 0,20$										
d _h	Kopfdurchmesser	6,00	7,00	8,00	9,00	10,00	12,00									
	Zul. Abweichung	$-0,50 / +0,10$														
d _s	Schaftdurchmesser	2,25	2,60	2,90	3,25	3,60	4,20									
	Zul. Abweichung	$-0,30 / +0,10$														
h	Kopfhöhe	1,90	2,10	2,50	2,70	3,00	3,80									
	Gewindesteigung	1,50	1,80	2,00	2,20	2,50	3,00-4,50									
p	Zul. Abweichung	$\pm 10\%$														
	Schaftfräsrippenlänge	3,75	4,25	4,75	5,50	6,00	7,00									
l _r ¹⁾	Zul. Abweichung	$\pm 0,75$				$\pm 1,00$										
	Antrieb TX	10		20		20	25	30								
	Antrieb PZ	1					2		3							
Schraubenlänge l_s		Standardgewindelänge l_{gf} = Vollgewinde l_{gp} = Teilgewinde Toleranz: $\pm 2,0$²⁾														
Nennmaß	min	max	l _{gf}	l _{gp}	l _{gf}	l _{gp}	l _{gf}	l _{gp}	l _{gf}	l _{gp}	l _{gf}	l _{gp}	l _{gf}	l _{gp}		
20	18,95	21,05	16		16		16		16							
25	23,75	26,25	21		21	18	20	18	20							
30	28,75	31,25	26	18	26	18	25	18	25	18	24					
35	33,50	36,50	31	24	31	24	30	24	30	24	29	24	28			
40	38,50	41,50	36	24	36	24	35	24	35	24	34	24	33	24		
45	43,50	46,50	41	30	41	30	40	30	40	30	39	30	38	30		
50	48,50	51,50			46	30	45	30	45	30	44	30	43	30		
55	53,50	56,50					50	36	50	36	49	36	48			
60	58,50	61,50						36		36		36	53	36		
70	68,50	71,50						42		42		42	63	42		
80	78,50	81,50						50		50		50	73	50		
90	88,25	91,75										60		60		
100	98,25	101,75										60		60		
110	108,25	111,75										70		70		
120	118,25	121,75										70		70		
in Abstufungen von 10 mm																
130-300	l _s - 2,00	l _s + 2,00														70

Alle Maße in mm

- Zwischenlängen bei l_s sind möglich
 - Schrauben mit Teilgewinde > 50 mm Länge mit Schaftfräsrippen
 - Gewindelängen zwischen $4 \times d \leq l_g \leq l_{gmax}$ sind möglich
- ²⁾ $10 \text{ mm} \geq l_g \leq 18 \text{ mm} \triangleq \pm 1,5 \text{ mm}$
 $18 \text{ mm} \geq l_g \leq 30 \text{ mm} \triangleq \pm 1,7 \text{ mm}$

fischer Power-Fast und Holzbauschrauben
Abmessungen und Werkstoff

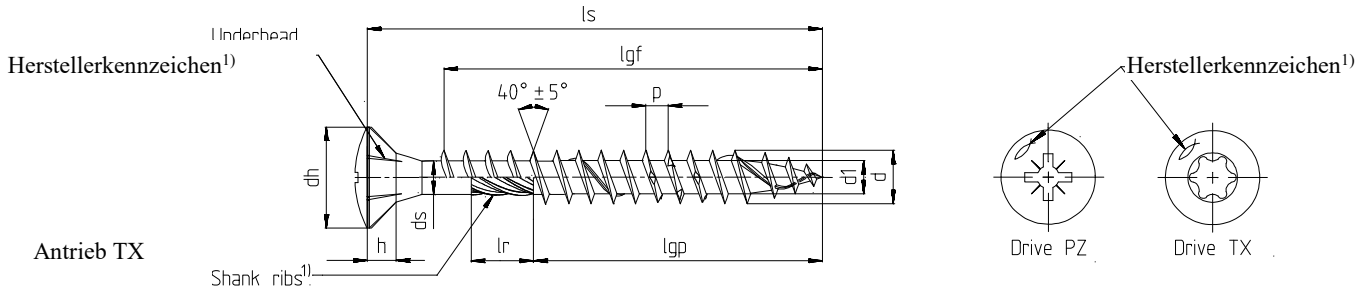

¹⁾ optional

Power-Fast selbstbohrende Schraube - Linsenkopfschraube mit Voll- oder Teilgewinde

<ul style="list-style-type: none"> ▪ Kohlenstoffstahl ▪ Mögliche Oberflächenbehandlungen: galvanisch verzinkt - gelb oder blau, galvanisch verzinkt - blau $\geq 12\mu\text{m}$, Bonuszink, brüniert, vernickelt, vermessingt 															
Nenndurchmesser		3,0	3,5	4,0	4,5	5,0	6,0								
d	Außendurchmesser	3,00	3,50	4,00	4,50	5,00	6,00								
	Zul. Abweichung	$\pm 0,30$													
d ₁	Kerndurchmesser	2,00	2,20	2,50	2,70	3,00	4,00								
	Zul. Abweichung	$-0,25 / +0,10$					$\pm 0,20$								
d _h	Kopfdurchmesser	6,00	7,00	8,00	9,00	10,00	12,00								
	Zul. Abweichung	$-0,50 / +0,10$													
d _s	Schaftdurchmesser	2,25	2,60	2,90	3,25	3,60	4,20								
	Zul. Abweichung	$-0,30 / +0,10$													
h	Kopfhöhe	1,90	2,10	2,50	2,70	3,00	3,40								
	Gewindesteigung	1,50	1,80	2,00	2,20	2,50	3,00-4,50								
p	Zul. Abweichung	$\pm 10\%$													
	Schaftfräsrippenlänge	3,75	4,25	4,75	5,50	6,00	7,00								
l _r ¹⁾	Zul. Abweichung	$\pm 0,75$					$\pm 1,00$								
	Antrieb TX	10			20			20	25	30					
Antrieb PZ	1	2					3								
Schraubenlänge l_s		Standardgewindelänge l_{gf} = Vollgewinde l_{gp} = Teilgewinde Toleranz: $\pm 2,0$²⁾													
Nennmaß	min	max	l _{gf}	l _{gp}	l _{gf}	l _{gp}	l _{gf}	l _{gp}	l _{gf}	l _{gp}	l _{gf}	l _{gp}	l _{gf}	l _{gp}	
20	18,95	21,05	16		16		16		16						
25	23,75	26,25	21		21	18	20	18	20						
30	28,75	31,25	26	18	26	18	25	18	25	18	24				
35	33,50	36,50	31	24	31	24	30	24	30	24	29	24	28		
40	38,50	41,50	36	24	36	24	35	24	35	24	34	24	33	24	
45	43,50	46,50	41	30	41	30	40	30	40	30	39	30	38	30	
50	48,50	51,50			46	30	45	30	45	30	44	30	43	30	
55	53,50	56,50					50	36	50	36	49	36	48		
60	58,50	61,50						36		36		36	53	36	
70	68,50	71,50						42		42		42	63	42	
80	78,50	81,50						50		50		50	73	50	

Alle Maße in mm

- Zwischenlängen bei l_s sind möglich
- Schrauben mit Teilgewinde > 50 mm Länge mit Schaftfräsrippen
- Gewindelängen zwischen $4 \times d \leq l_g \leq l_{gmax}$ sind möglich

²⁾ $10 \text{ mm} \geq l_g \leq 18 \text{ mm} \triangleq \pm 1,5 \text{ mm}$
 $18 \text{ mm} \geq l_g \leq 30 \text{ mm} \triangleq \pm 1,7 \text{ mm}$

fischer Power-Fast und Holzbauschrauben
Abmessungen und Werkstoff

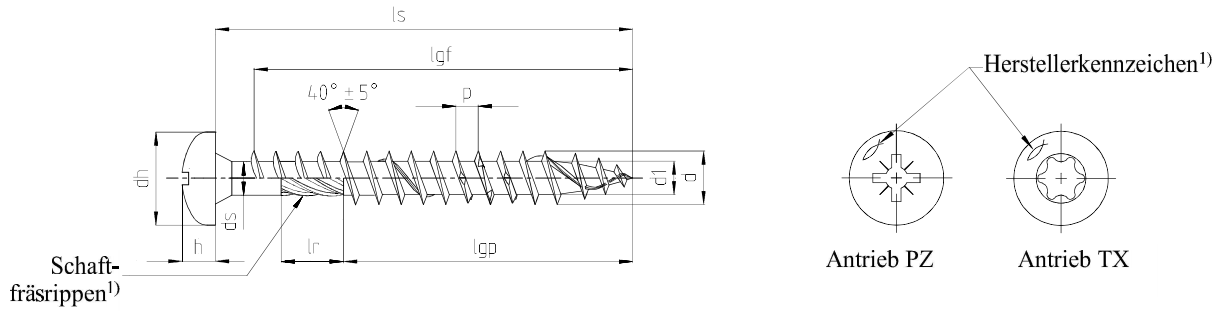

¹⁾ optional

Power-Fast selbstbohrende Schraube – Pan head Schraube mit Voll- oder Teilgewinde

<ul style="list-style-type: none"> ▪ Kohlenstoffstahl ▪ Mögliche Oberflächenbehandlungen: galvanisch verzinkt - gelb oder blau, galvanisch verzinkt - blau $\geq 12\mu\text{m}$, Bonuszink, brüniert, vernickelt, vermessingt 															
Nenndurchmesser		3,0	3,5	4,0	4,5	5,0	6,0								
d	Außendurchmesser	3,00	3,50	4,00	4,50	5,00	6,00								
	Zul. Abweichung	$\pm 0,30$													
d _i	Kerndurchmesser	2,00	2,20	2,50	2,70	3,00	4,00								
	Zul. Abweichung	$-0,25 / +0,10$					$\pm 0,20$								
d _h	Kopfdurchmesser	6,00	7,00	8,00	9,00	10,00	12,00								
	Zul. Abweichung	$-0,50 / +0,10$													
d _s	Schaftdurchmesser	2,25	2,60	2,90	3,25	3,60	4,20								
	Zul. Abweichung	$-0,30 / +0,10$													
h	Kopfhöhe	2,30	2,50	2,90	3,10	3,40	3,80								
	Gewindesteigung	1,50	1,80	2,00	2,20	2,50	3,00-4,50								
p	Zul. Abweichung	$\pm 10\%$													
	Schaftfräsrippenlänge	3,75	4,25	4,75	5,50	6,00	7,00								
l _r ¹⁾	Zul. Abweichung	$\pm 0,75$				$\pm 1,00$									
	Antrieb TX	10			20			20	25	30					
Antrieb PZ	1	2					3								
Schraubenlänge l_s		Standardgewindelänge l_{gf} = Vollgewinde l_{gp} = Teilgewinde Toleranz: $\pm 2,0$ ²⁾													
Nennmaß	min	max	l_{gf}	l_{gp}	l_{gf}	l_{gp}	l_{gf}	l_{gp}	l_{gf}	l_{gp}	l_{gf}	l_{gp}	l_{gf}	l_{gp}	
20	18,95	21,05	16		16		16		16						
25	23,75	26,25	21		21	18	20	18	20						
30	28,75	31,25	26	18	26	18	25	18	25	18	24				
35	33,50	36,50	31	24	31	24	30	24	30	24	29	24	28		
40	38,50	41,50		24	36	24	35	24	35	24	34	24	33	24	
45	43,50	46,50		30		30	40	30	40	30	39	30	38	30	
50	48,50	51,50			30	45	30	45	30	44	36	43	30		
55	53,50	56,50				50	36	50	36	49	36	48			
60	58,50	61,50					36		36		42	53	36		
70	68,50	71,50					42		42		50	63	42		
80	78,50	81,50					50		50		50	73	50		
90	88,25	91,75									60		60		
100	98,25	101,75									60		60		

Alle Maße in mm

- Zwischenlängen bei l_s sind möglich
- Schrauben mit Teilgewinde > 50 mm Länge mit Schaftfräsrippen
- Gewindelängen zwischen $4 \times d \leq l_g \leq l_{gmax}$ sind möglich

²⁾ $10 \text{ mm} \geq l_g \leq 18 \text{ mm} \triangleq \pm 1,5 \text{ mm}$
 $18 \text{ mm} \geq l_g \leq 30 \text{ mm} \triangleq \pm 1,7 \text{ mm}$

fischer Power-Fast und Holzbauschrauben
Abmessungen und Werkstoff

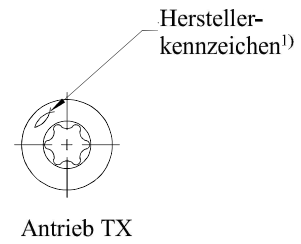
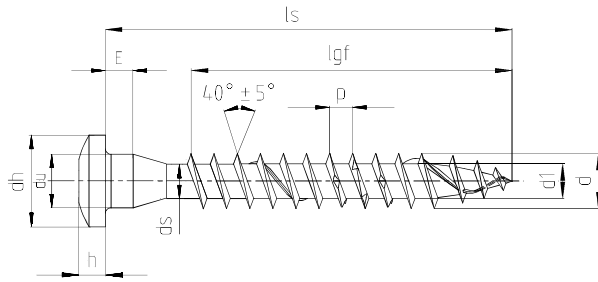

Antrieb TX

¹⁾ optional

Power-Fast selbstbohrende Schraube - Holzverbinderschraube mit Vollgewinde

<ul style="list-style-type: none"> ▪ Kohlenstoffstahl ▪ Mögliche Oberflächenbehandlungen: galvanisch verzinkt - gelb oder blau, galvanisch verzinkt - blau $\geq 12\mu\text{m}$, Bonuszink 																		
Nenndurchmesser		5,0																
d	Außendurchmesser	5,00																
	Zul. Abweichung	-0,30																
d ₁	Kerndurchmesser	3,00																
	Zul. Abweichung	$\pm 0,20$																
d _u	Unterkopfdurchmesser	5,00																
	Zul. Abweichung	-0,35																
d _h	Kopfdurchmesser	8,25																
	Zul. Abweichung	$\pm 0,40$																
E	Höhe	2,50																
	Zul. Abweichung	$\pm 0,30$																
h	Kopfhöhe	2,60																
	Zul. Abweichung	$\pm 0,40$																
p	Gewindesteigung	2,50																
	Zul. Abweichung	$\pm 10\%$																
Antrieb TX		20	25															
Schraubenlänge l _s		Standardgewindelänge l _{gf} = Vollgewinde l _{gp} =Teilgewinde Toleranz: $\pm 2,0$ ²⁾																
Nennmaß	min	max	l _{gf}	l _{gp}														
20	18,95	21,05	14															
25	23,75	26,25	19															
30	28,75	31,25	24															
35	33,50	36,50	29															
40	38,50	41,50	34															
45	43,50	46,50	39															
50	48,50	51,50	44															
55	53,50	56,50	49															
60	58,50	61,50	54															
70	68,50	71,50	64															
80	78,50	81,50	74															

Alle Maße in mm

- Zwischenlängen bei l_s sind möglich
- Gewindelängen zwischen $4 \times d \leq l_g \leq l_{gmax}$ sind möglich

²⁾ $10 \text{ mm} \geq l_g \leq 18 \text{ mm} \cong \pm 1,5 \text{ mm}$
 $18 \text{ mm} \geq l_g \leq 30 \text{ mm} \cong \pm 1,7 \text{ mm}$

fischer Power-Fast und Holzbauschrauben	
Abmessungen und Werkstoff	

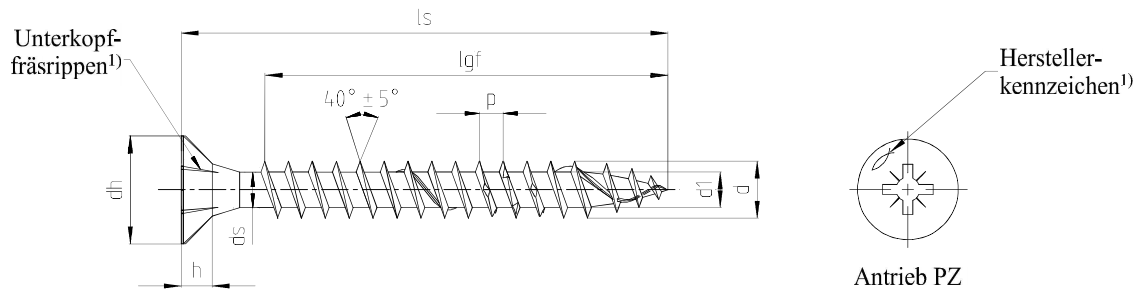

¹) optional

Power-Fast selbstbohrende Schraube – Senkkopfschraube mit kleinem Kopf und Vollgewinde

<ul style="list-style-type: none"> ▪ Kohlenstoffstahl ▪ Mögliche Oberflächenbehandlungen: galvanisch verzinkt - gelb oder blau, galvanisch verzinkt - blau $\geq 12\mu\text{m}$ 									
Nenndurchmesser		3,0	3,5	4,0					
d	Außendurchmesser	3,00	3,50	4,00					
	Zul. Abweichung	$\pm 0,30$							
d ₁	Kerndurchmesser	2,00	2,20	2,50					
	Zul. Abweichung	$-0,25 / +0,10$							
d _h	Kopfdurchmesser	5,00	6,00	7,00					
	Zul. Abweichung	$-0,50 / +0,10$							
h	Kopfhöhe	1,90	2,10	2,50					
	Gewindesteigung	1,50	1,80	2,00					
p	Zul. Abweichung	$\pm 10\%$							
	Antrieb PZ	1	2						
Schraubenlänge l _s			Standardgewindelänge l _{gf} = Vollgewinde l _{gp} =Teilgewinde Toleranz: $\pm 2,0$ ²⁾						
Nennmaß	min	max	l _{gf}	l _{gp}	l _{gf}	l _{gp}	l _{gf}	l _{gp}	
20	18,95	21,05	16		16		16		
25	23,75	26,25	21		21		20		
30	28,75	31,25	26						

Alle Maße in mm

- Zwischenlängen bei l_s sind möglich
- Gewindelängen zwischen $4 \times d \leq l_g \leq l_{gmax}$ sind möglich

²⁾ $10 \text{ mm} \geq l_g \leq 18 \text{ mm} \triangleq \pm 1,5 \text{ mm}$
 $18 \text{ mm} \geq l_g \leq 30 \text{ mm} \triangleq \pm 1,7 \text{ mm}$

fischer Power-Fast und Holzbauschrauben	
Abmessungen und Werkstoff	

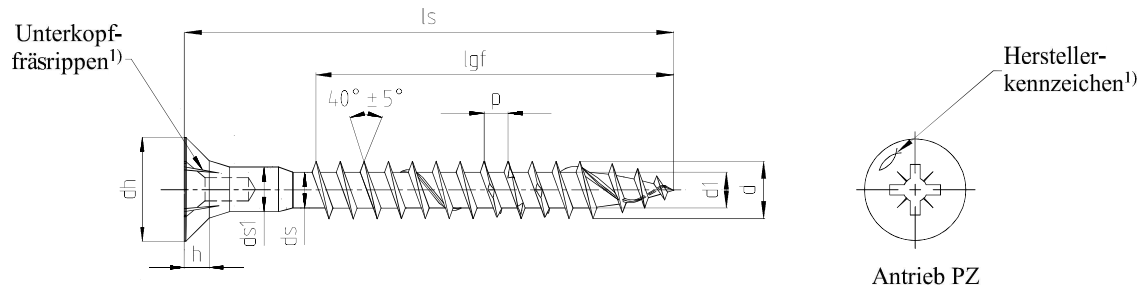

1) optional

Power-Fast selbstbohrende Schraube - Senkkopfschraube mit Kopflochbohrung und Vollgewinde

<ul style="list-style-type: none"> ▪ Kohlenstoffstahl ▪ Mögliche Oberflächenbehandlungen: galvanisch verzinkt - gelb oder blau, galvanisch verzinkt - blau $\geq 12\mu\text{m}$ 																				
Nenndurchmesser		4,0	4,5	5,0	6,0															
d	Außendurchmesser	4,00	4,50	5,00	6,00															
	Zul. Abweichung	$\pm 0,30$																		
d ₁	Kerndurchmesser	2,50	2,70	3,00	4,00															
	Zul. Abweichung	$-0,25 / +0,10$		$\pm 0,20$																
d _h	Kopfdurchmesser	8,00	9,00	10,00	12,00															
	Zul. Abweichung	$-0,50 / +0,10$																		
d _s	Schaftdurchmesser	2,90	3,25	3,60	4,30															
	Zul. Abweichung	$-0,30 / +0,10$																		
h	Kopfhöhe	2,50	2,70	3,00	3,80															
	Gewindesteigung	2,00	2,20	2,50	3,00-4,50															
p	Zul. Abweichung	$\pm 10\%$																		
	Schaftdurchmesser	3,70	3,85	4,50	4,20															
d _{s1}	Zul. Abweichung	$-0,10$																		
	Antrieb PZ	2			3															
Schraubenlänge l _s		Standardgewindelänge l _{gf} = Vollgewinde l _{gp} = Teilgewinde Toleranz: $\pm 2,0^2)$																		
Nennmaß	min	max	l _{gf}	l _{gp}	l _{gf}	l _{gp}	l _{gf}	l _{gp}	l _{gf}	l _{gp}										
25	23,75	26,25	17,5																	
27	25,75	28,25	19,5																	
30	28,75	31,25	22,5		19															
35	33,50	36,50	27,5		24															
40	38,50	41,50	32,5		29		29													
45	43,50	46,50	37,5		34		34													
50	48,50	51,50	42,5		39		39		41											
55	53,50	56,50	47,5		44		44		46											
60	58,50	61,50	50,0		49		49		51											
70	68,50	71,50			59		60		60											
80	78,50	81,50			59		60		60											
90	88,25	91,75			59		60		60											
100	98,25	101,75					60		60											

Alle Maße in mm

- Zwischenlängen bei l_s sind möglich
- Gewindelängen zwischen $4 \times d \leq l_g \leq l_{gmax}$ sind möglich

2) $10 \text{ mm} \geq l_g \leq 18 \text{ mm} \triangleq \pm 1,5 \text{ mm}$
 $18 \text{ mm} \geq l_g \leq 30 \text{ mm} \triangleq \pm 1,7 \text{ mm}$

fischer Power-Fast und Holzbauschrauben	
Abmessungen und Werkstoff	

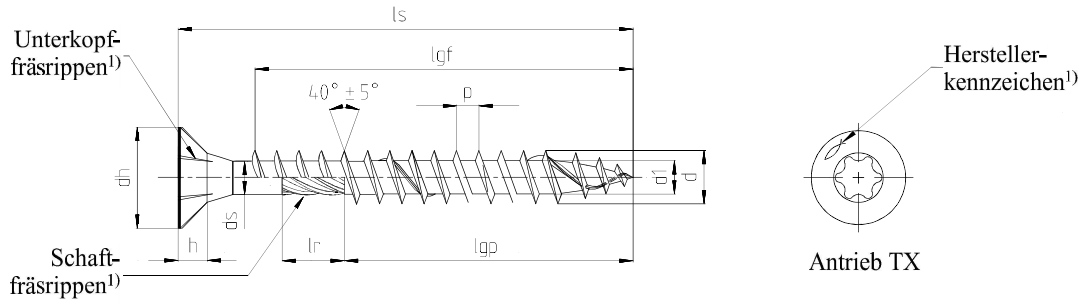

¹⁾ optional

Power-Fast Holzbauschraube - Senkkopfschraube mit Voll- oder Teilgewinde

<ul style="list-style-type: none"> ▪ Kohlenstoffstahl ▪ Mögliche Oberflächenbehandlungen: galvanisch verzinkt - gelb oder blau, galvanisch verzinkt - blau $\geq 12\mu\text{m}$, Bonuszink 																				
Nenndurchmesser		6,0	8,0	10,0	12,0															
d	Außendurchmesser	6,00	8,00	10,00	12,00															
	Zul. Abweichung	$\pm 0,30$		$\pm 0,40$	$\pm 0,50$															
d _i	Kerndurchmesser	4,00	5,40	6,40	7,60															
	Zul. Abweichung	$\pm 0,20$		$\pm 0,30$	$\pm 0,30$															
d _h	Kopfdurchmesser	12,00	14,40	18,40	22,40															
	Zul. Abweichung	$-0,50 / +0,10$	$\pm 0,40$		$\pm 0,50$															
d _s	Schaftdurchmesser	4,30	5,90	7,10	8,30															
	Zul. Abweichung	$-0,30 / +0,10$	$\pm 0,20$		$\pm 0,20$															
h	Kopfhöhe	3,80	5,10	6,10	7,20															
	Gewindesteigung	3,00-4,50	6,00	7,50																
p	Zul. Abweichung	$\pm 10\%$																		
	Schaftfräsrippenlänge	8,00	13,00																	
l _r ¹⁾	Zul. Abweichung	$-2,00$																		
	Antrieb TX	30	40		50															
Schraubenlänge l _s		Standardgewindelänge l _{gf} = Vollgewinde l _{gp} =Teilgewinde Toleranz: $\pm 2,0$																		
Nennmaß	min	max	l _{gf}	l _{gp}	l _{gf}	l _{gp}	l _{gf}	l _{gp}	l _{gf}	l _{gp}										
60	58,50	61,50	50	36				52												
80	78,50	81,50	70	50	70	50		52												
90	88,25	91,75		60	80	50														
100	98,25	101,75		60	80	50		52			60									
120	118,25	121,75		70	100	75		80			80									
140	138,00	142,00		70		75		80			80									
160	158,00	162,00		70		75		80			80									
180	178,00	182,00		70		75		100			100									
200	198,00	202,00		70		100		100			100									
220	218,00	222,00		70		100		100			100									
240	238,00	242,00		70		100		100			120									
260	258,00	262,00		70		100		100			120									
280	278,00	282,00		70		100		115			120									
300	298,00	302,00		70		100		115			120									
320	317,00	323,00				100		115												
330	327,00	333,00						115												
340	337,00	343,00					100	115												
350	347,00	353,00									145									
360	357,00	363,00				100		115												
380	377,00	383,00				100		115												
400	397,00	403,00																		
450/500	l _s -3,00	l _s +3,00				100		115			145									
550/600	l _s -3,00	l _s +3,00									145									

Alle Maße in mm

- Zwischenlängen bei l_s sind möglich
- Gewindelängen zwischen $4 \times d \leq l_g \leq l_{gmax}$ sind möglich

fischer Power-Fast und Holzbauschrauben
Abmessungen und Werkstoff

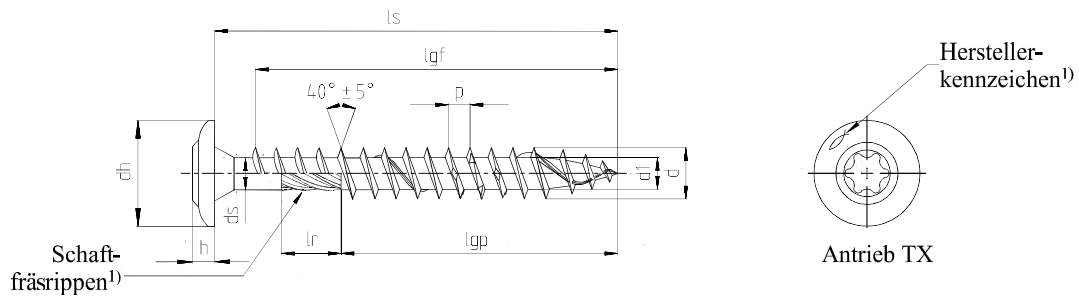

¹⁾ optional

Power-Fast Holzbauschraube - Tellerkopfschraube mit Voll- oder Teilgewinde

<ul style="list-style-type: none"> ▪ Kohlenstoffstahl ▪ Mögliche Oberflächenbehandlungen: galvanisch verzinkt - gelb oder blau, galvanisch verzinkt - blau ≥12µm, Bonuszink 																				
Nenndurchmesser		6,0	8,0	10,0	12,0															
d	Außendurchmesser	6,00	8,00	10,00	12,00															
	Zul. Abweichung	±0,30		±0,40	±0,50															
d _i	Kerndurchmesser	4,00	5,40	6,40	7,60															
	Zul. Abweichung	±0,20			±0,30															
d _h	Kopfdurchmesser	13,70	21,00	24,70	27,90															
	Zul. Abweichung	-0,70/+1,30	±1,00	-1,20/+2,80	-1,40/+2,60															
d _s	Schaftdurchmesser	4,30	5,90	7,10	8,30															
	Zul. Abweichung	-0,30/+0,10	±0,20		±0,30															
h	Kopfhöhe	3,50		5,60	6,70															
	Zul. Abweichung	±1,00		±0,50																
p	Gewindesteigung	3,00-4,50	6,00	7,50																
	Zul. Abweichung	±10%																		
l _r ¹⁾	Schaftfräsrippenlänge	8,00	13,00																	
	Zul. Abweichung	-2,00																		
Antrieb TX		30	40		50															
Schraubenlänge l _s		Standardgewindelänge l _{gf} = Vollgewinde l _{gp} =Teilgewinde Toleranz: ± 2,0																		
Nennmaß	min	max	l _{gf}	l _{gp}	l _{gf}	l _{gp}	l _{gf}	l _{gp}	l _{gf}	l _{gp}										
60	58,50	61,50	50	36																
80	78,50	81,50	70	50	70	50		52												
90	88,25	91,75		60	80	50														
100	98,25	101,75		60	80	50		52		60										
120	118,25	121,75		70	100	75		80		80										
140	138,00	142,00		70		75		80		80										
160	158,00	162,00		70		75		80		80										
180	178,00	182,00		70		75		100		100										
200	198,00	202,00		70		100				100										
220	218,00	222,00		70		100		100		100										
240	238,00	242,00		70		100		100		100										
260	258,00	262,00		70		100		100		100										
280	278,00	282,00		70		100		115		120										
300	298,00	302,00		70		100		115		120										
320	317,00	323,00				100		115												
330	327,00	333,00						115												
340	337,00	343,00				100		115												
350	347,00	353,00								145										
in Abstufungen von 10 mm																				
360-500	l _s -3,00	l _s +3,00				100		115												
in Abstufungen von 50 mm																				
550-600	l _s -3,00	l _s +3,00								145										

Alle Maße in mm

- Zwischenlängen bei l_s sind möglich
- Gewindelängen zwischen 4×d ≤ l_g ≤ l_{gmax} sind möglich

fischer Power-Fast und Holzbauschrauben
Abmessungen und Werkstoff

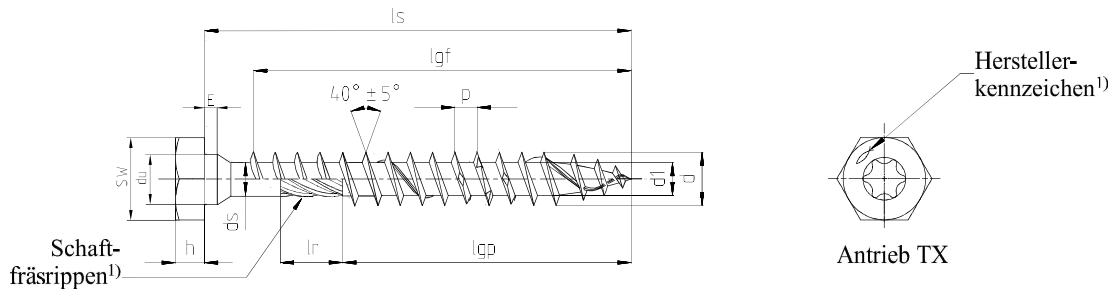

¹⁾ optional

Power-Fast Holzbauschraube - Sechskantschraube mit Voll- oder Teilgewinde

<ul style="list-style-type: none"> ▪ Kohlenstoffstahl ▪ Mögliche Oberflächenbehandlungen: galvanisch verzinkt - gelb oder blau, galvanisch verzinkt - blau >12µm, Bonuszink 															
Nenndurchmesser		6,0	8,0	10,0	12,0										
d	Außendurchmesser	6,00	8,00	10,00	12,00										
	Zul. Abweichung	±0,30		±0,40	±0,50										
di	Kerndurchmesser	4,00	5,40	6,40	7,60										
	Zul. Abweichung	±0,20			±0,30										
du	Unterkopfdurchmesser	6,25	8,25	10,30	12,40										
	Zul. Abweichung	-0,80		-0,90	-1,00										
SW	Schlüsselweite	9,90	12,80	14,80	16,80										
	Zul. Abweichung	±0,30													
E	Höhe	2,00	2,10	2,30	3,30										
	Zul. Abweichung	±0,50													
ds	Schaftdurchmesser	4,30	5,90	7,10	8,30										
	Zul. Abweichung	-0,30/+0,10		±0,20											
h	Kopfhöhe	4,00	4,50	5,20	5,70										
	Zul. Abweichung	±0,30	±0,40	±0,50											
p	Gewindesteigung	3,00-4,50		6,00	7,50										
	Zul. Abweichung	±10%													
lr ¹⁾	Schaftfräsrippenlänge	8,00		13,00											
	Zul. Abweichung	-2,00													
Antrieb TX		30		40		50									
Schraubenlänge ls		Standardgewindelänge l _{gf} = Vollgewinde l _{gp} =Teilgewinde Toleranz: ± 2,0 ²⁾													
Nennmaß	min	max	l _{gf}	l _{gp}	l _{gf}	l _{gp}	l _{gf}	l _{gp}	l _{gf}	l _{gp}					
60	58,5	61,5	50	30											
80	78,5	81,5	70	50	70	50		52							
90	88,25	91,75		60	80	50									
100	98,25	101,75		60	80	50		52		60					
120	118,25	121,75		70	100	75		80		80					
140/160	l _s -2,00	l _s +2,00		70		75		80		80					
180	178,00	182,00		70		75		100		100					
200/220	l _s -2,00	l _s +2,00		70		100		100		100					
240/260	l _s -2,00	l _s +2,00		70		100		100		120					
280/300	l _s -2,00	l _s +2,00		70		100		115		120					
320	317,00	323,00				100		115							
330	327,00	333,00						115							
340	337,00	343,00				100		115							
350	347,00	353,00								145					
360/380	l _s -3,00	l _s +3,00				100		115							
in Abstufungen von 50 mm															
400-500	l _s -3,00	l _s +3,00				100		115		145					
550/600	l _s -3,00	l _s +3,00								145					

Alle Maße in mm

- Zwischenlängen bei l_s sind möglich
- Gewindelängen zwischen 4×d ≤ l_g ≤ l_{gmax} sind möglich

²⁾ 18 mm ≥ l_g ≤ 30 mm ≅ ±1,7 mm

fischer Power-Fast und Holzbauschrauben
Abmessungen und Werkstoff

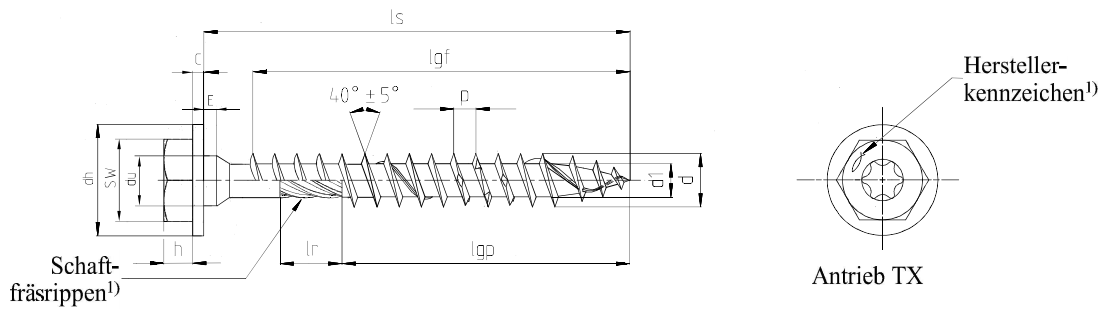

¹⁾ optional

Power-Fast Holzbauschraube - Sechskantschraube mit Scheibe und Voll- oder Teilgewinde

<ul style="list-style-type: none"> ▪ Kohlenstoffstahl ▪ Mögliche Oberflächenbehandlungen: galvanisch verzinkt - gelb oder blau, galvanisch verzinkt - blau ≥12µm, Bonuszink 															
Nenndurchmesser		6,0	8,0	10,0	12,0										
d	Außendurchmesser	6,00	8,00	10,00	12,00										
	Zul. Abweichung	±0,30		±0,40	±0,50										
d _i	Kerndurchmesser	4,00	5,40	6,40	7,60										
	Zul. Abweichung	±0,20		±0,30											
d _h	Kopfdurchmesser	15,00	18,00	21,50	23,40										
	Zul. Abweichung	1,20		1,50											
d _u	Unterkopfdurchmesser	6,25	8,25	10,30	12,40										
	Zul. Abweichung	-0,80		-0,90	-1,00										
SW	Schlüsselweite	9,90	12,80	14,80	16,80										
	Zul. Abweichung	±0,30													
c	Scheibenhöhe	1,80	2,00	2,20	2,50										
E	Höhe	2,00	2,10	2,30	3,30										
	Zul. Abweichung	±0,50													
d _s	Schaftdurchmesser	4,30	5,90	7,10	8,30										
	Zul. Abweichung	-0,30/+0,10		±0,20											
h	Kopfhöhe	4,00	4,50	5,20	5,70										
	Zul. Abweichung	±0,30	±0,40	±0,50											
p	Gewindesteigung	3,00-4,50	6,00	7,50											
	Zul. Abweichung	±10%													
l _r ¹⁾	Schaftfräsrippenlänge	8,00		13,00											
	Zul. Abweichung	-2,00													
Antrieb TX		30		40		50									
Schraubenlänge l _s		Standardgewindelänge l _{gf} = Vollgewinde l _{gp} = Teilgewinde Toleranz: ± 2,0 ²⁾													
Nennmaß	min	max	l _{gf}	l _{gp}	l _{gf}	l _{gp}	l _{gf}	l _{gp}	l _{gf}	l _{gp}					
60	58,50	61,50	50	30											
80	78,50	81,50	70	50	70	50		52							
90	88,25	91,75		60	80	50									
100	98,25	101,75		60	80	50		52		60					
120	118,25	121,75		70	100	75		80		80					
140/160	l _s -2,00	l _s +2,00		70		75		80		80					
180	178,00	182,00		70		75		100		100					
200/220	l _s -2,00	l _s +2,00		70		100		100		100					
240/260	l _s -2,00	l _s +2,00		70		100		100		120					
280/300	l _s -2,00	l _s +2,00		70		100		115		120					
320	317,00	323,00				100		115							
330	327,00	333,00						115							
340	337,00	343,00				100		115							
350	347,00	353,00								145					
360/380	l _s -3,00	l _s +3,00				100		115							
in Abstufungen von 50 mm															
400-500	l _s -3,00	l _s +3,00				100		115		145					
550/600	l _s -3,00	l _s +3,00								145					

Alle Maße in mm

- Zwischenlängen bei l_s sind möglich
- Gewindelängen zwischen 4×d ≤ l_g ≤ l_{gmax} sind möglich

²⁾ 18 mm ≥ l_g ≤ 30 mm ≙ ±1,7 mm

fischer Power-Fast und Holzbauschrauben
Abmessungen und Werkstoff

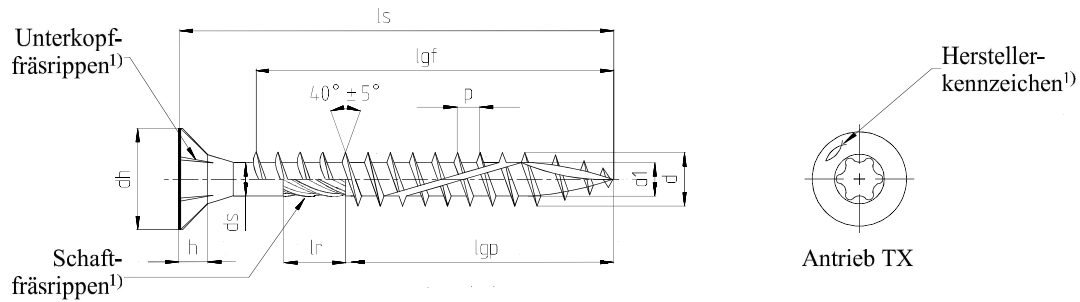

¹⁾ optional

FCS Holzbauschraube - Senkkopfschraube mit Voll- oder Teilgewinde

<ul style="list-style-type: none"> ▪ Kohlenstoffstahl ▪ Mögliche Oberflächenbehandlungen: galvanisch verzinkt - gelb oder blau, galvanisch verzinkt - blau $\geq 12\mu\text{m}$, Bonuszink 														
Nenndurchmesser		8,0	10,0											
d	Außendurchmesser	8,00	10,00											
	Zul. Abweichung	$\pm 0,30$	$\pm 0,40$											
d _i	Kerndurchmesser	5,40	6,35											
	Zul. Abweichung	$-0,30/+0,20$												
d _h	Kopfdurchmesser	14,40	18,40											
	Zul. Abweichung	$\pm 0,40$												
d _s	Schaftdurchmesser	5,90	7,10											
	Zul. Abweichung	$-0,30/+0,10$												
h	Kopfhöhe	6,00-7,00	7,50-8,50											
	Gewindesteigung	5,20	5,60											
p	Zul. Abweichung	$\pm 10\%$												
	Schaftfräsrippenlänge	13,0												
l _r ¹⁾	Zul. Abweichung	-2,00												
	Antrieb TX	40												
Schraubenlänge l _s			Standardgewindelänge l _{gf} = Vollgewinde l _{gp} =Teilgewinde Toleranz: $\pm 2,0$											
Nennmaß	min	max	l _{gf}	l _{gp}	l _{gf}	l _{gp}								
80	78,50	81,50	70	50		52								
90	88,25	91,75	80	50		52								
100	98,25	101,75	80	50		52								
110	108,25	111,75	100	75		80								
120	118,25	121,75		75		80								
in Abstufungen von 10 mm														
130-400	l _s -2,00	l _s +2,00		75		80								

Alle Maße in mm

- Zwischenlängen bei l_s sind möglich
- Gewindelängen zwischen $4 \times d \leq l_g \leq l_{gmax}$ sind möglich

fischer Power-Fast und Holzbauschrauben	
Abmessungen und Werkstoff	

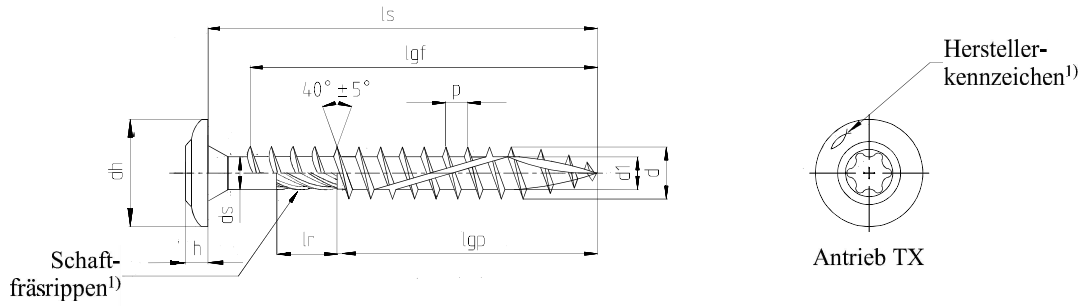

¹⁾ optional

FCS Holzbauschraube – Tellerkopfschraube mit Teilgewinde

<ul style="list-style-type: none"> ▪ Kohlenstoffstahl ▪ Mögliche Oberflächenbehandlungen: galvanisch verzinkt - gelb oder blau, galvanisch verzinkt - blau $\geq 12\mu\text{m}$ 											
Nenndurchmesser		8,0	10,0								
d	Außendurchmesser	8,00	10,00								
	Zul. Abweichung	-0,40/+0,30	$\pm 0,40$								
di	Kerndurchmesser	5,40	6,35								
	Zul. Abweichung	$\pm 0,30$									
dh	Kopfdurchmesser	21,00	24,70								
	Zul. Abweichung	$\pm 1,00$	-1,20/+2,80								
ds	Schaftdurchmesser	5,90	7,10								
	Zul. Abweichung	-0,30/+0,20									
h	Kopfhöhe	2,50-4,50	3,70-5,70								
	Gewindesteigung	5,20	5,60								
p	Zul. Abweichung	$\pm 10\%$									
	Schaftfräsrippenlänge	12,00									
lr ¹⁾	Zul. Abweichung	$\pm 1,00$									
	Antrieb TX	40									
Schraubenlänge ls			Standardgewindelänge lgr= Vollgewinde lgp=Teilgewinde Toleranz: $\pm 2,0$								
Nennmaß	min	max	lgr	lgp	lgr	lgp					
80	78,50	81,50	70	50		52					
90	88,25	91,75	80	50		52					
100	98,25	101,75	80	50		52					
110	108,25	111,75	100	75		80					
120	118,25	121,75		75		80					
in Abstufungen von 10 mm											
130-400	ls-2,00	ls+2,00		75		80					

Alle Maße in mm

- Zwischenlängen bei ls sind möglich
- Gewindelängen zwischen $4 \times d \leq l_g \leq l_{gmax}$ sind möglich

fischer Power-Fast und Holzbauschrauben	
Abmessungen und Werkstoff	

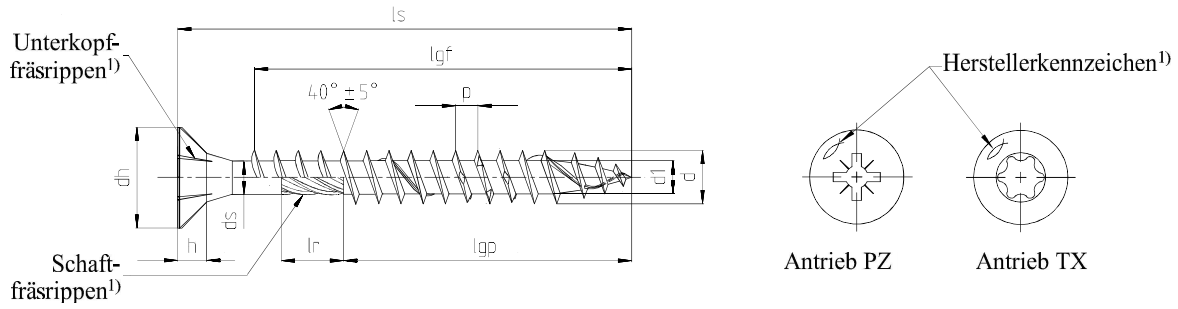

¹⁾ optional

Power-Fast selbstbohrende Schraube - Senkkopfschraube mit Voll- oder Teilgewinde

▪ Edelstahl															
Nenndurchmesser		3,0	3,5	4,0	4,5	5,0	6,0								
d	Außendurchmesser	3,00	3,50	4,00	4,50	5,00	6,00								
	Zul. Abweichung	±0,30													
d ₁	Kerndurchmesser	2,00	2,20	2,50	2,70	3,00	4,00								
	Zul. Abweichung	-0,25 / +0,10					±0,20								
d _h	Kopfdurchmesser	6,00	7,00	8,00	9,00	10,00	12,00								
	Zul. Abweichung	-0,50 / +0,10													
d _s	Schaftdurchmesser	2,25	2,60	2,90	3,25	3,60	4,30								
	Zul. Abweichung	-0,30 / +0,10													
h	Kopfhöhe	1,90	2,10	2,50	2,70	3,00	3,80								
	Gewindesteigung	1,50	1,80	2,00	2,20	2,50	3,00-4,50								
p	Zul. Abweichung	±10%													
	Schaftfräsrippenlänge	3,75	4,25	4,75	5,50	6,00	7,00								
l _r ¹⁾	Zul. Abweichung	±0,75				±1,00									
	Antrieb TX	10			20			20	25	30					
Antrieb PZ	1	2								3					
Schraubenlänge l _s		Standardgewindelänge l _{gf} = Vollgewinde l _{gp} =Teilgewinde Toleranz: ± 2,0 ²⁾													
Nennmaß	min	max	l _{gf}	l _{gp}	l _{gf}	l _{gp}	l _{gf}	l _{gp}	l _{gf}	l _{gp}	l _{gf}	l _{gp}	l _{gf}	l _{gp}	
20	18,95	21,05	16	16	16	16	16	16							
25	23,75	26,25	21		21	18	20	18	20						
30	28,75	31,25	26	18	26	18	25	18	25	18	24				
35	33,50	36,50	31	24	31	24	30	24	30	24	29	24	28		
40	38,50	41,50	36	24	36	24	35	24	35	24	34	24	33	24	
45	43,50	46,50	41		41	30	40	30	40	30	39	30	38	30	
50	48,50	51,50			46	30	45	30	45	30	44	30	43	30	
55	53,50	56,50					50	36	50	36	49	36	48		
60	58,50	61,50						36		36		36	53	36	
70	68,50	71,50						42		42		42	63	42	
80	78,50	81,50						50		50		50	73	50	
90	88,25	91,75										60		60	
100	98,25	101,75										60		60	
110	108,25	111,75										70		70	
120	118,25	121,75										70		70	
in Abstufungen von 10 mm															
130-300	l _s -2,00	l _s +2,00												70	

Alle Maße in mm

- Zwischenlängen bei l_s sind möglich
- Schrauben mit Teilgewinde > 50 mm Länge mit Schaftfräsrippen
- Gewindelängen zwischen 4×d ≤ l_g ≤ l_{gmax} sind möglich

²⁾ 10 mm ≥ l_g ≤ 18 mm ≅ ±1,5 mm
18 mm ≥ l_g ≤ 30 mm ≅ ±1,7 mm

fischer Power-Fast und Holzbauschrauben
Abmessungen und Werkstoff

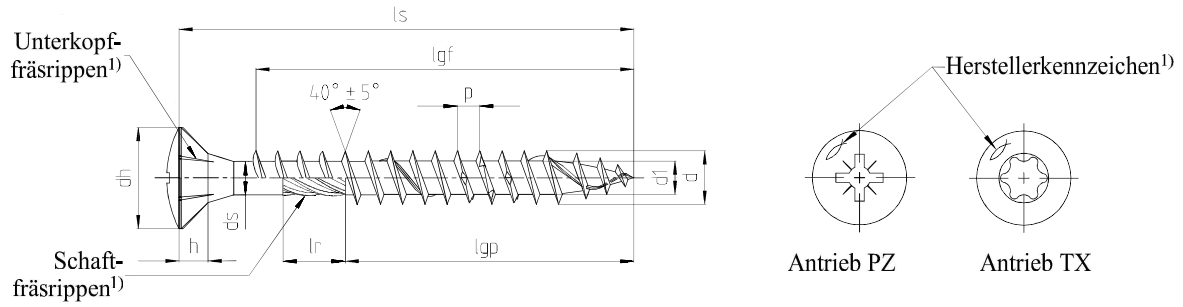

¹⁾ optional

Power-Fast selbstbohrende Schraube - Linsenkopf mit Voll- oder Teilgewinde

■ Edelstahl																
Nenndurchmesser		3,0	3,5	4,0	4,5	5,0	6,0									
d	Außendurchmesser	3,00	3,50	4,00	4,50	5,00	6,00									
	Zul. Abweichung	±0,30														
d ₁	Kerndurchmesser	2,00	2,20	2,50	2,70	3,00	4,00									
	Zul. Abweichung	-0,25 / +0,10					±0,20									
d _h	Kopfdurchmesser	6,00	7,00	8,00	9,00	10,00	12,00									
	Zul. Abweichung	-0,50 / +0,10														
d _s	Schaftdurchmesser	2,25	2,60	2,90	3,25	3,60	4,30									
	Zul. Abweichung	-0,30 / +0,10														
h	Kopfhöhe	1,90	2,10	2,50	2,70	3,00	3,80									
p	Gewindesteigung	1,50	1,80	2,00	2,20	2,50	3,00-4,50									
	Zul. Abweichung	±10%														
l _r ¹⁾	Schaftfräsrippenlänge	3,75	4,25	4,75	5,50	6,00	7,00									
	Zul. Abweichung	±0,75					±1,00									
Antrieb TX		10			20			20	25	30						
Antrieb PZ		1	2								3					
Schraubenlänge l _s		Standardgewindelänge l _{gf} = Vollgewinde l _{gp} =Teilgewinde										Toleranz: ± 2,0 ²⁾				
Nennmaß	min	max	l _{gf}	l _{gp}	l _{gf}	l _{gp}	l _{gf}	l _{gp}	l _{gf}	l _{gp}	l _{gf}	l _{gp}	l _{gf}	l _{gp}		
20	18,95	21,05	16		16		16		16							
25	23,75	26,25	21		21	18	21	18	20							
30	28,75	31,25	26	18	26	18	26	18	25	18	24					
35	33,50	36,50	31	24	31	24	31	24	30	24	29	24	28			
40	38,50	41,50		24	36	24	36	24	35	24	34	24	33			
45	43,50	46,50		30		30	41	30	40	30	39	30	38			
50	48,50	51,50				30	46	30	45	30	44	30	43			
55	53,50	56,50						36		36		36				
60	58,50	61,50						36		36		36	53			
70	68,50	71,50						42		42		42	63			
80	78,50	81,50						50		50		50	73			

Alle Maße in mm

- Zwischenlängen bei l_s sind möglich
- Schrauben mit Teilgewinde > 50 mm Länge mit Schaftfräsrippen
- Gewindelängen zwischen 4×d ≤ l_g ≤ l_{gmax} sind möglich

²⁾ 10 mm ≥ l_g ≤ 18 mm ± ±1,5 mm
 18 mm ≥ l_g ≤ 30 mm ± ±1,7 mm

fischer Power-Fast und Holzbauschrauben
Abmessungen und Werkstoff

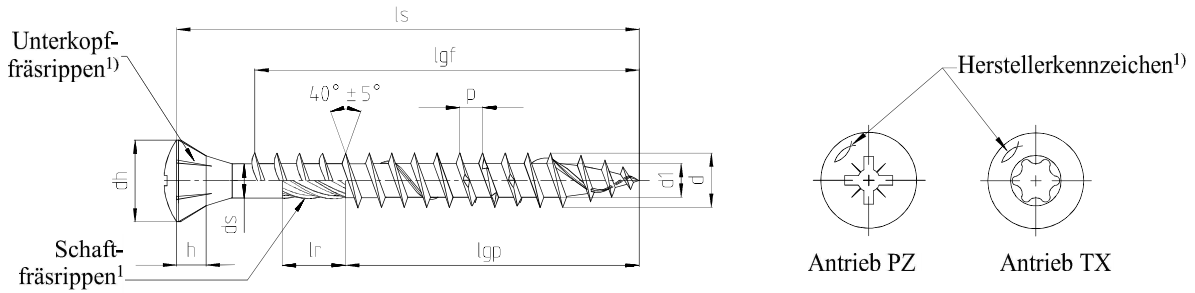

¹⁾ optional

Power-Fast selbstbohrende Schraube - Fassadenschraube mit Voll- oder Teilgewinde

Edelstahl													
Nenndurchmesser		4,0	4,5	5,0									
d	Außendurchmesser	4,00	4,50	5,00									
	Zul. Abweichung	±0,30											
d ₁	Kerndurchmesser	2,50	2,70	3,00									
	Zul. Abweichung	-0,25 / +0,10		±0,20									
d _h	Kopfdurchmesser	6,90	6,90	7,80									
	Zul. Abweichung	±0,50											
d _s	Schaftdurchmesser	2,90	3,25	3,60									
	Zul. Abweichung	-0,30 / +0,10											
h	Kopfhöhe	2,50	2,70	3,00									
	Gewindesteigung	2,00	2,20	2,50									
p	Zul. Abweichung	±10%											
	l _r ¹⁾	Schaftfräsrippenlänge	4,75	5,50	6,00								
Zul. Abweichung		±0,75	±1,00										
Antrieb TX		20		20	25								
Antrieb PZ		2											
Schraubenlänge l _s			Standardgewindelänge l _{gf} = Vollgewinde l _{gp} = Teilgewinde Toleranz: ± 2,0 ²⁾										
Nennmaß	min	max	l _{gf}	l _{gp}	l _{gf}	l _{gp}	l _{gf}	l _{gp}					
20	18,95	21,05	16		16								
25	23,75	26,25	21	18	20								
30	28,75	31,25	26	18	25	18	24						
35	33,50	36,50	31	24	30	24	29	24					
40	38,50	41,50	36	24	35	24	34	24					
45	43,50	46,50	41	30	40	30	39	30					
50	48,50	51,50	46	30	45	30	44	30					
55	53,50	56,50		36		36		36					
60	58,50	61,50		36		36		36					
70	68,50	71,50		42		42		42					
80	78,50	81,50		50		50		50					
90	88,25	91,75						60					
100	98,25	101,75						60					
110	108,25	111,75						70					
120	118,25	121,75						70					

Alle Maße in mm

- Zwischenlängen bei l_s sind möglich
- Schrauben mit Teilgewinde > 50 mm Länge mit Schaftfräsrippen
- Gewindelängen zwischen 4×d ≤ l_g ≤ l_{gmax} sind möglich

²⁾ 10mm ≥ l_g ≤ 18mm ≅ ±1,5mm
18mm ≥ l_g ≤ 30mm ≅ ±1,7mm

fischer Power-Fast und Holzbauschrauben
Abmessungen und Werkstoff

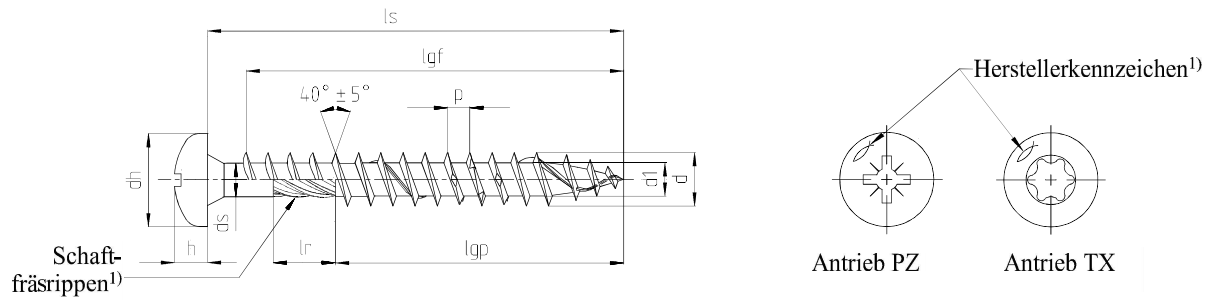

¹⁾ optional

Power-Fast selbstbohrende Schraube – Pan head Schraube mit Voll- oder Teilgewinde

▪ Edelstahl																
Nenndurchmesser		3,0	3,5	4,0	4,5	5,0	6,0									
d	Außendurchmesser	3,00	3,50	4,00	4,50	5,00	6,00									
	Zul. Abweichung	±0,30														
d ₁	Kerndurchmesser	2,00	2,20	2,50	2,70	3,00	4,00									
	Zul. Abweichung	-0,25 / +0,10					±0,20									
d _h	Kopfdurchmesser	6,00	7,00	8,00	9,00	10,00	12,00									
	Zul. Abweichung	-0,50 / +0,10														
d _s	Schaftdurchmesser	2,25	2,60	2,90	3,25	3,60	4,30									
	Zul. Abweichung	-0,30 / +0,10														
h	Kopfhöhe	2,30	2,50	2,90	3,10	3,40	3,80									
	Gewindesteigung	1,50	1,80	2,00	2,20	2,50	3,00-4,50									
p	Zul. Abweichung	±10%														
	l _r ¹⁾	Schaftfräsrippenlänge	3,75	4,25	4,75	5,50	6,00	7,00								
Zul. Abweichung		±0,75					±1,00									
Antrieb TX		10			20			20	25	30						
Antrieb PZ		1	2							3						
Schraubenlänge l _s			Standardgewindelänge l _{gf} = Vollgewinde l _{gp} =Teilgewinde										Toleranz: ± 2,0 ²⁾			
Nennmaß	min	max	l _{gf}	l _{gp}	l _{gf}	l _{gp}	l _{gf}	l _{gp}	l _{gf}	l _{gp}	l _{gf}	l _{gp}	l _{gf}	l _{gp}		
20	18,95	21,05	16		16		16									
25	23,75	26,25	21		21	18	20	18	20							
30	28,75	31,25	26	18	26	18	25	18	25	18	24					
35	33,50	36,50	31	24	31	24	30	24	30	24	29	24	28			
40	38,50	41,50		24	36	24	35	24	35	24	34	24	33	24		
45	43,50	46,50		30		30	40	30	40	30	39	30	38	30		
50	48,50	51,50				30	45	30	45	30	44	36	43	30		
55	53,50	56,50					50	36	50	36	49	36	48			
60	58,50	61,50						36		36		42	53	36		
70	68,50	71,50						42		42		50	63	42		
80	78,50	81,50						50		50		50	73	50		
90	88,25	91,75										60		60		
100	98,25	101,75										60		60		

Alle Maße in mm

- Zwischenlängen bei l_s sind möglich
- Schrauben mit Teilgewinde > 50 mm Länge mit Schaftfräsrippen
- Gewindelängen zwischen 4×d ≤ l_g ≤ l_{gmax} sind möglich

²⁾ 10 mm ≥ l_g ≤ 18 mm ≙ ±1,5 mm
18 mm ≥ l_g ≤ 30 mm ≙ ±1,7 mm

fischer Power-Fast und Holzbauschrauben
Abmessungen und Werkstoff

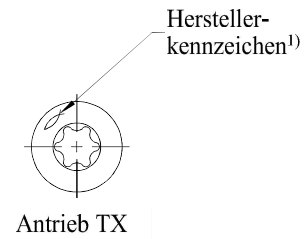
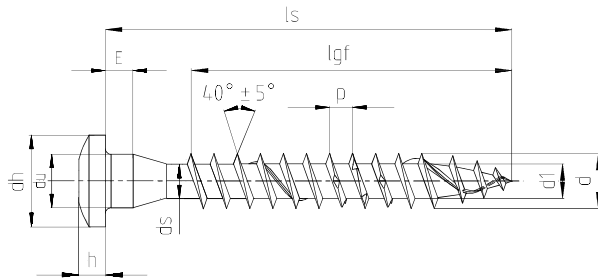

¹) optional

Power-Fast selbstbohrende Schraube - Holzverbinderschraube mit Vollgewinde

<ul style="list-style-type: none"> Edelstahl 											
Nenndurchmesser		5,0									
d	Außendurchmesser	5,00									
	Zul. Abweichung	-0,30									
d _l	Kerndurchmesser	3,00									
	Zul. Abweichung	±0,20									
d _u	Unterkopfdurchmesser	5,00									
	Zul. Abweichung	-0,35									
d _h	Kopfdurchmesser	8,25									
	Zul. Abweichung	±0,40									
E	Höhe	2,50									
	Zul. Abweichung	±0,30									
h	Kopfhöhe	2,60									
p	Gewindesteigung	2,50									
	Zul. Abweichung	±10%									
Antrieb TX		20	25								
Schraubenlänge l _s		Standardgewindelänge l _{gf} = Vollgewinde l _{gp} =Teilgewinde Toleranz: ± 2,0 ²⁾									
Nennmaß	min	max	l _{gf}	l _{gp}							
20	18,95	21,05	14								
25	23,75	26,25	19								
30	28,75	31,25	24								
35	33,50	36,50	29								
40	38,50	41,50	34								
45	43,50	46,50	39								
50	48,50	51,50	44								
55	53,50	56,50	49								
60	58,50	61,50	54								
70	68,50	71,50	64								
80	78,50	81,50	74								

Alle Maße in mm

- Zwischenlängen bei l_s sind möglich
- Gewindelängen zwischen 4×d ≤ l_g ≤ l_{gmax} sind möglich

²⁾ 10 mm ≥ l_g ≤ 18 mm ≅ ±1,5 mm
 18 mm ≥ l_g ≤ 30 mm ≅ ±1,7 mm

fischer Power-Fast und Holzbauschrauben	
Abmessungen und Werkstoff	

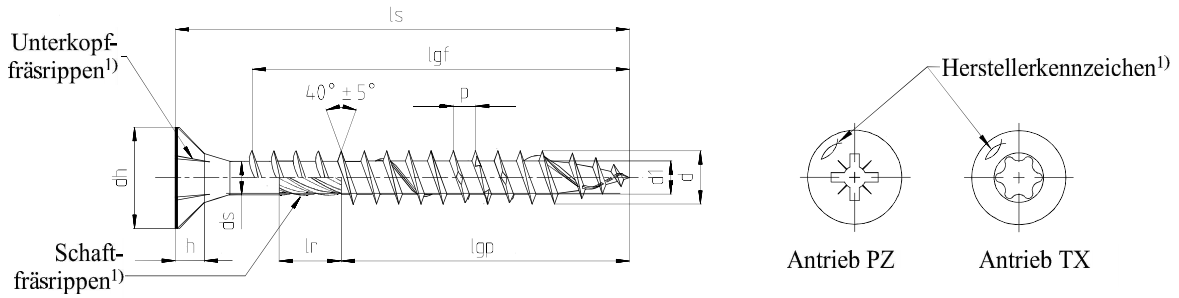

¹⁾ optional

Power-Fast Holzbauschraube - Senkkopfschraube mit Voll- oder Teilgewinde

■ Edelstahl													
Nenndurchmesser		6,0		8,0									
d	Außendurchmesser	6,00		8,00									
	Zul. Abweichung	$\pm 0,30$											
d ₁	Kerndurchmesser	4,00		5,40									
	Zul. Abweichung	$\pm 0,20$											
d _h	Kopfdurchmesser	12,00		14,40									
	Zul. Abweichung	$-0,50/+0,10$		$\pm 0,40$									
d _s	Schaftdurchmesser	4,30		5,90									
	Zul. Abweichung	$-0,30/+0,10$		$\pm 0,20$									
h	Kopfhöhe	3,80		5,10									
p	Gewindesteigung	3,00-4,50		6,00									
	Zul. Abweichung	$\pm 10\%$											
l _r ¹⁾	Schaftfräsrippenlänge	7,00		13,00									
	Zul. Abweichung	$\pm 1,00$		$-2,00$									
Antrieb TX		30		40									
Antrieb PZ		3		-									
Schraubenlänge l _s				Standardgewindelänge l _{gf} = Vollgewinde l _{gp} =Teilgewinde Toleranz: $\pm 2,0$									
Nennmaß	min	max		l _{gf}	l _{gp}	l _{gf}	l _{gp}						
60	58,50	61,50		50	36								
80	78,50	81,50		70	50	70	50						
90	88,25	91,75			60	80	50						
100	98,25	101,75			60	80	50						
120	118,25	121,75			70	100	75						
140	138,00	142,00			70		75						
160	158,00	162,00			70		75						
180	178,00	182,00			70		75						
in Abstufungen von 20 mm													
200-300	l _s -2,00	l _s +2,00			70		100						
in Abstufungen von 20 mm													
320-500	l _s -3,00	l _s +3,00					100						

Alle Maße in mm

- Zwischenlängen bei l_s sind möglich
- Schrauben mit Teilgewinde > 50 mm Länge mit Schaftfräsrippen
- Gewindelängen zwischen $4 \times d \leq l_g \leq l_{gmax}$ sind möglich

fischer Power-Fast und Holzbauschrauben
Abmessungen und Werkstoff

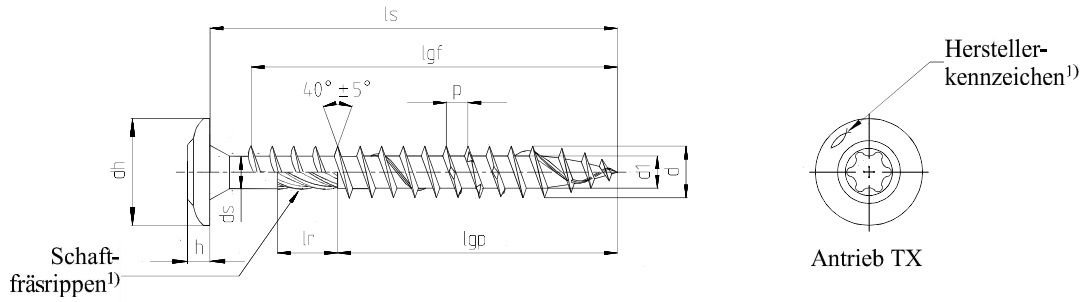

¹⁾ optional

Power-Fast Holzbauschraube - Tellerkopfschraube mit Voll- oder Teilgewinde

■ Edelstahl													
Nenndurchmesser		6,0	8,0										
d	Außendurchmesser	6,00	8,00										
	Zul. Abweichung	±0,30											
d ₁	Kerndurchmesser	4,00	5,40										
	Zul. Abweichung	-0,30/+0,20											
d _h	Kopfdurchmesser	13,70	21,00										
	Zul. Abweichung	-0,70/+1,30	±1,00										
d _s	Schaftdurchmesser	4,30	5,90										
	Zul. Abweichung	-0,30/+0,10											
h	Kopfhöhe	3,50											
	Zul. Abweichung	±1,00											
p	Gewindesteigung	3,00-4,50	6,00										
	Zul. Abweichung	±10%											
l _r ¹⁾	Schaftfräsrippenlänge	8,00	13,00										
	Zul. Abweichung	-2,00											
Antrieb TX		30	40										
Schraubenlänge l _s				Standardgewindelänge l _{gf} = Vollgewinde l _{gp} =Teilgewinde Toleranz: ± 2,0									
Nennmaß	min	max		l _{gf}	l _{gp}	l _{gf}	l _{gp}						
60	58,50	61,50		50	36								
80	78,50	81,50		70	50	70	50						
90	88,25	91,75			60	80	50						
100	98,25	101,75			60	80	50						
120	118,25	121,75			70	100	75						
140	138,00	142,00			70		75						
160	158,00	162,00			70		75						
180	178,00	182,00			70		75						
in Abstufungen von 20 mm													
200-300	l _s -2,00	l _s +2,00			70		100						
in Abstufungen von 20 mm													
200-300	l _s -3,00	l _s +3,00					100						

Alle Maße in mm

- Zwischenlängen bei l_s sind möglich
- Gewindelängen zwischen 4×d ≤ l_g ≤ l_{gmax} sind möglich

fischer Power-Fast und Holzbauschrauben	
Abmessungen und Werkstoff	

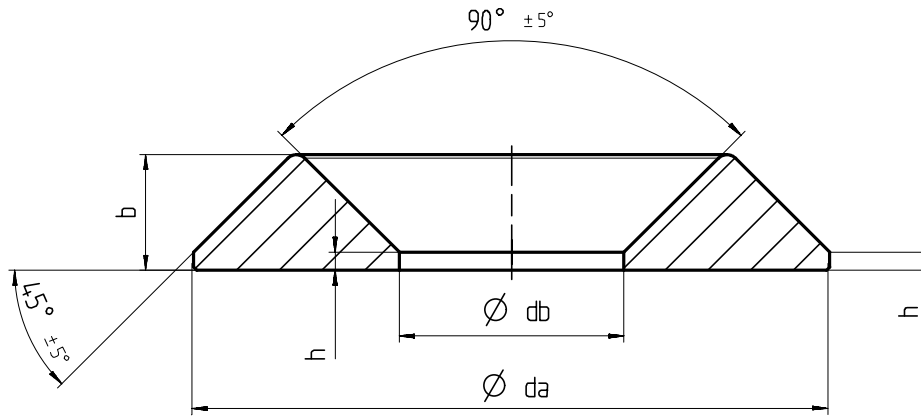

Scheibe für Power-Fast und Holzbauschrauben

<ul style="list-style-type: none"> ▪ Kohlenstoffstahl - Mögliche Oberflächenbehandlungen: galvanisch verzinkt - gelb oder blau, galvanisch verzinkt - blau $\geq 12\mu\text{m}$, Bonuszink ▪ Edelstahl 								
Nenn Durchmesser		Typ 1				Typ 2		
Größe		6	8	10	12	6	8	10
db	Innendurchmesser	6,70	8,70	11,20	6,70	6,70	8,70	11,20
	Zul. Abweichung	-0,40						
da	Außendurchmesser	21	30	35	43	21	25,50	30,50
	Zul. Abweichung	$\pm 2,0$						
b	Höhe	4,70	5,20	6,20	8,30	4,70	5,20	6,20
	Zul. Abweichung	-0,40						
h	Höhe	1,50	1,80	2,00	2,20	1,50	1,80	2,00
	Zul. Abweichung	-0,15						

Alle Maße in mm

fischer Power-Fast und Holzbauschrauben	
Zubehör	

Befestigung von Aufdach-Dämmsystemen

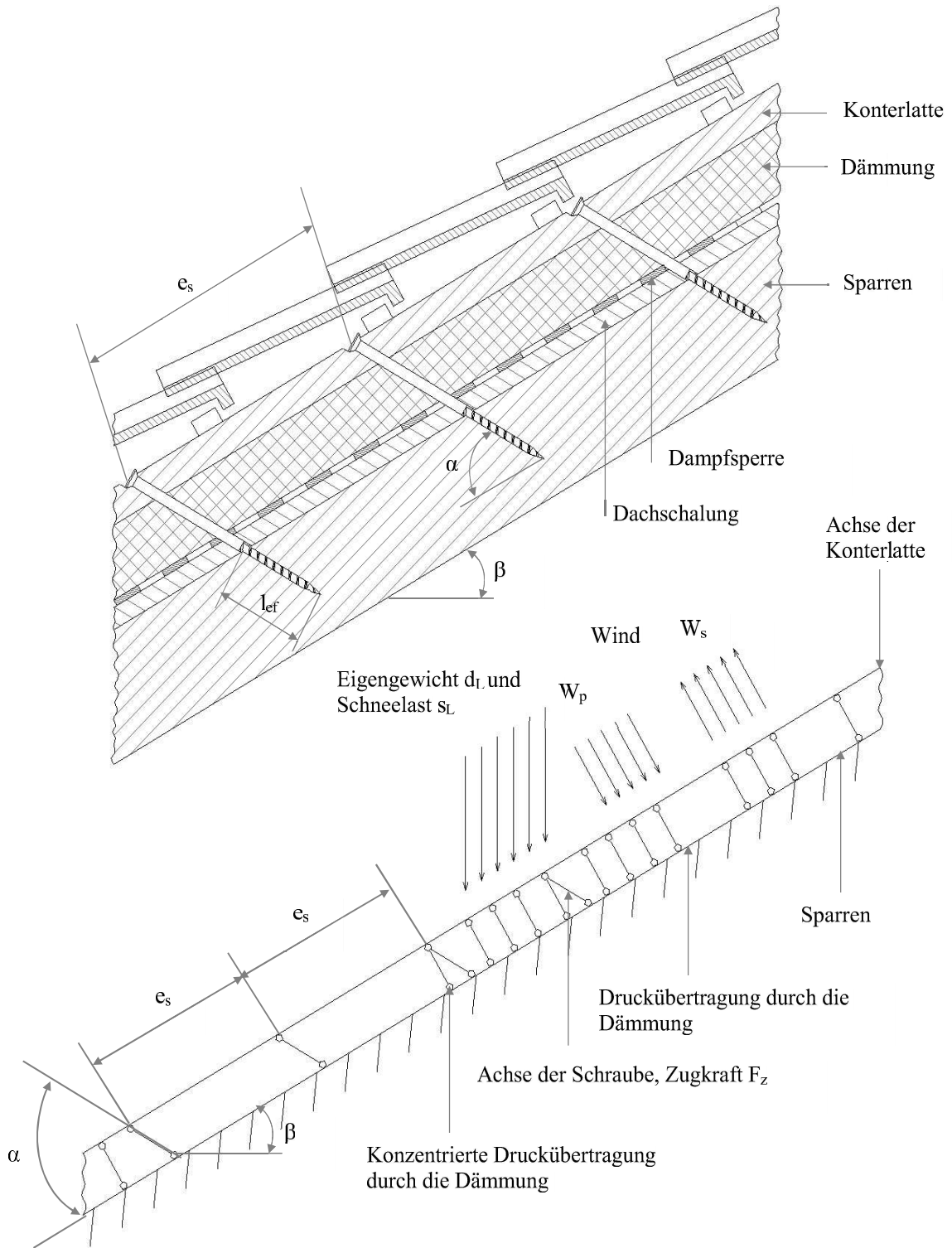

- | | | | | | |
|---------|---|------------------|----------|---|---|
| W_s | = | Windsog | W_p | = | Winddruck |
| e_s | = | Schraubenabstand | l_{ef} | = | Gewindeeinschraubtiefe im Sparren |
| β | = | Dachneigung | α | = | Winkel zwischen Schrauben- und Sparrenachse |

fischer Power-Fast und Holzbauschrauben	
Bemessung	

Befestigung von Aufdach-Dämmsystemen

Punktlasten F_b senkrecht zu den Latten

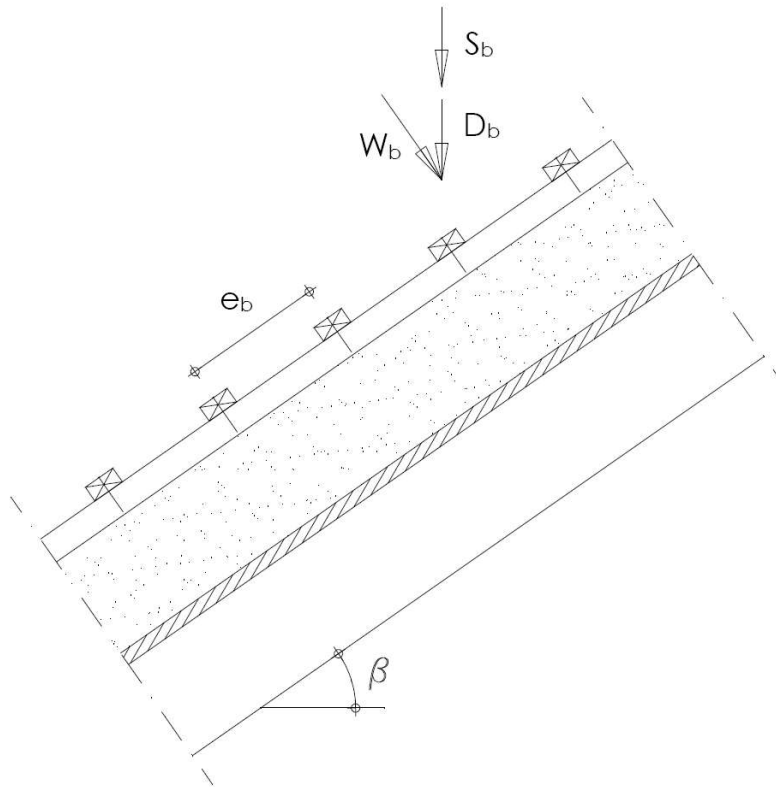

$$D_b = d \cdot e_b \cdot e_r$$

$$S_b = s \cdot e_b \cdot e_r \cdot \cos \beta$$

$$W_b = w_p \cdot e_b \cdot e_r$$

$$F_b = W_b + (D_b + S_b) \cdot \cos \beta$$

Darin sind

- D_b = Punktlast aus Eigenlast
- S_b = Punktlast aus Schneelast
- W_b = Punktlast senkrecht zur Latte aus Windlast (Druck)
- e_b = Lattenabstand
- e_r = Sparrenabstand (=Konterlattenabstand)
- s = Schneelast pro m^2 Grundfläche
- w_p = Winddruck auf Dachfläche
- d = Eigenlast pro m^2 Dachfläche
- β = Dachneigung

fischer Power-Fast und Holzbauschrauben	
Bemessung	

Punktlasten F_s senkrecht zu den Latten durch die Schrauben

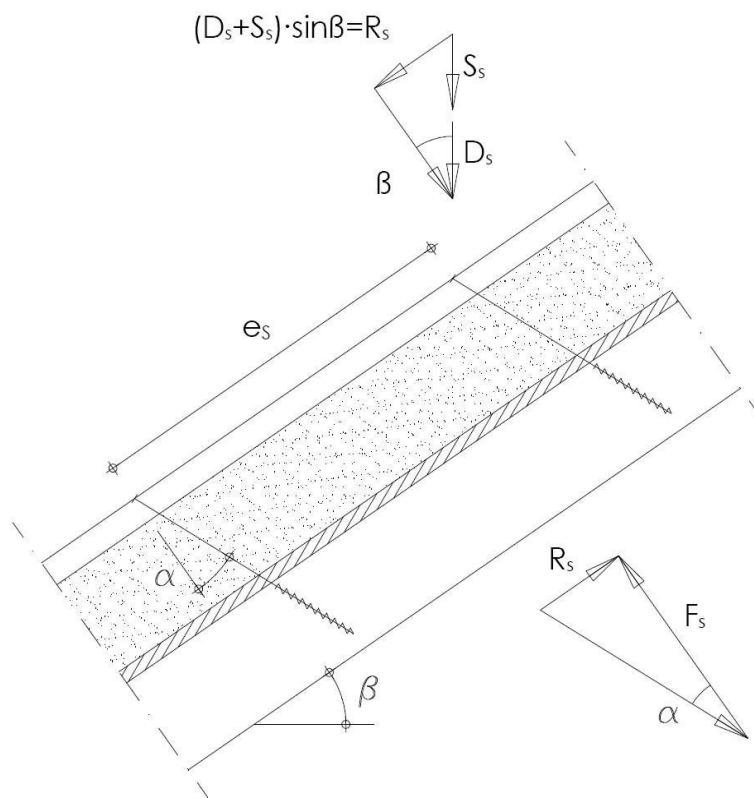

$$D_s = d \cdot e_s \cdot e_r$$

$$S_s = s \cdot e_s \cdot e_r \cdot \cos \beta$$

$$R_s = (D_s + S_s) \cdot \sin \beta$$

$$F_s = R_s / \tan \alpha$$

Darin sind

D_s = Punktlast aus Eigenlast

S_s = Punktlast aus Schneelast

R_s = Schublast des Dachs aus Eigenlast und Schneelast

e_s = Schraubenabstand

e_r = Sparrenabstand (=Konterlattenabstand)

α = Winkel zwischen Schraubenachse und der Senkrechten zur Sparrenachse

fischer Power-Fast und Holzbauschrauben

Bemessung

Bemessung der Konterlatten

Das Biegemoment errechnet sich aus :

$$M = \frac{(F_b + F_s) \cdot \ell_{\text{char}}}{4}$$

Darin sind :

$$\ell_{\text{char}} = \text{charakteristische Länge } \ell_{\text{char}} = 4 \sqrt{\frac{4 \cdot EI}{w_{\text{ef}} \cdot K}}$$

EI = Biegesteifigkeit der Konterlatte

K = Bettungsziffer

w_{ef} = Effektive Breite des Wärmedämmstoffs

F_b = Punktlasten senkrecht zur Latte

F_s = Punktlasten senkrecht zur Latte, Belastung im Schraubenkopfbereich

Die Bettungsziffer K kann aus dem Elastizitätsmoduls E_{HI} und der Dicke t_{HI} der Wärmedämmung ermittelt werden, sofern die effektive Breite w_{ef} der Wärmedämmung unter Druck bekannt ist. Aufgrund der Lastausbreitung in der Wärmedämmung ist die effektive Breite w_{ef} größer als die Breite der Latte bzw. des Sparrens. Für weitere Berechnungen kann die effective Breite w_{ef} der Wärmedämmung wie folgt bestimmt werden:

$$w_{\text{ef}} = w + t_{\text{HI}} / 2$$

mit

w = Minimum aus der Breite der Konterlatte bzw. des Sparrens

t_{HI} = Dicke der Wärmedämmung

$$K = \frac{E_{\text{HI}}}{t_{\text{HI}}}$$

Folgende Bedingung muss dabei erfüllt werden :

$$\frac{\sigma_{\text{m,d}}}{f_{\text{m,d}}} = \frac{M_{\text{d}}}{W \cdot f_{\text{m,d}}} \leq 1$$

Bei Berechnung des Widerstandsmoments W ist der Nettoquerschnitt zu berücksichtigen.

Die Beanspruchung aus Schub ist wie folgt zu berechnen :

$$V = \frac{(F_b + F_s)}{2}$$

Folgende Bedingung muss dabei erfüllt werden :

$$\frac{\tau_{\text{d}}}{f_{\text{v,d}}} = \frac{1,5 \cdot V_{\text{d}}}{A \cdot f_{\text{v,d}}} \leq 1$$

Bei Berechnung der Querschnittfläche ist der Nettoquerschnitt zu berücksichtigen.

Bemessung der Wärmedämmung

Die Druckspannung in der Wärmedämmung ist wie folgt zu berechnen:

$$\sigma = \frac{1,5 \cdot F_b + F_s}{2 \cdot \ell_{\text{char}} \cdot W}$$

Der Bemessungswert der Druckspannung soll nicht größer als 110 % der Druckspannung bei 10 % Stauchung sein, berechnet nach EN 826.

fischer Power-Fast und Holzbauschrauben	
Bemessung	

Bemessung der Schrauben

Die Schrauben werden vorwiegend in Richtung der Schraubenachse beansprucht. Die axiale Zugkraft in der Schraube kann aus den Schubbeanspruchungen des Daches R_s berechnet werden.

$$T_s = \frac{R_s}{\cos \alpha}$$

Die Tragfähigkeit der in Achsrichtung beanspruchten Schrauben ist das Minimum aus den Bemessungswerten der axialen Tragfähigkeit auf Herausziehen des Schraubengewindes, der Kopfdurchziehtragfähigkeit der Schraube und der Zugtragfähigkeit der Schraube.

Um die Verformung des Schraubenkopfes bei einer Dicke der Wärmedämmung von über 200 mm bzw. einer Druckfestigkeit der Wärmedämmung unter $0,12 \text{ N/mm}^2$ zu begrenzen, ist die axiale Tragfähigkeit der Schrauben gegen Herausziehen mit den Faktoren k_1 und k_2 abzumindern :

$$F_{ax,a,Rd} = \min \left\{ \begin{array}{l} k_{ax} * f_{ax,d} * d * l_{ef} * k_1 * k_2 * \left(\frac{\rho_k}{350}\right)^{0,8} \\ f_{head,d} * d_h^2 * \left(\frac{\rho_k}{350}\right)^{0,8} \\ f_{tens,d} \end{array} \right. \quad [\text{N}]$$

mit :

$f_{ax,d}$	Bemessungswert der Ausziehtragfähigkeit des Gewindeteils der Schraube
d	Gewindeaußendurchmesser der Schraube
l_{ef}	Einbindetiefe des Gewindeteils der Schraube im Sparren, $l_{ef} \geq 40 \text{ mm}$
α	Winkel zwischen Faserrichtung und Schraubenachse ($\alpha \geq 30^\circ$)
ρ_k	Charakteristische Rohdichte des Holzbauteils [kg/m^3]
$f_{head,d}$	Bemessungswert der Kopfdurchziehtragfähigkeit der Schraube
d_h	Kopfdurchmesser
k_1	$\min \{1; 200/t_{HI}\}$
k_2	$\min \{1; \sigma_{10\%}/0,12\}$
t_{HI}	Dicke der Wärmedämmung [mm]
$\sigma_{10\%}$	Druckspannung der Wärmedämmung bei 10 % Stauchung [N/mm^2]
$f_{tens,d}$	Bemessungswert der Zugkraft der Schraube [N]

Wenn in o.e. Formel die Faktoren k_1 und k_2 erfüllt sind, muss die Verformung der Latten bei der Bemessung der Tragfähigkeit der Schrauben nicht berücksichtigt werden. Als Alternative zu den Latten können auch Platten mit einer Dicke von 20 mm aus Sperrholz gemäß EN 636 oder Europäischer Technischer Zulassung bzw. Bewertung oder nationalen jeweils am Einbauort geltenden Vorschriften, Spanplatten gemäß EN 312 oder ETA (Europäisch Technische Zulassung bzw. Bewertung) oder nationalen, jeweils am Einbauort geltenden Vorschriften, OSB-Platten gemäß EN 300 oder einer ETA oder nationalen, jeweils am Einbauort geltenden Vorschriften sowie Vollholzplatten gemäß EN 13353 oder einer ETA oder nationalen, jeweils am Einbauort geltenden Vorschriften oder aus Brettsperrholz gemäß einer ETA verwendet werden.

fischer Power-Fast und Holzbauschrauben	
Bemessung	

Wärmedämmstoff auf Sparren mit parallelen Schrauben senkrecht zur Dachebene

Alternativ zu den Latten können ebenfalls Platten mit einer Mindestdicke von 20 mm aus Sperrholz nach EN 636, Spanplatten nach EN 312, OSB / 3 und OSB / 4 nach EN 300 oder ETA und Massivholzplatten nach EN 13353 verwendet werden.

Charakteristische Tragfähigkeit einer Schraube unter Querbelastung:

$$F_{v,Rk} = \min \left\{ \begin{array}{l} f_{h,b,k} \cdot d \cdot t_b \\ f_{h,r,k} \cdot d \cdot t_r \\ \frac{f_{h,b,k} \cdot d \cdot \beta}{1 + \beta} \cdot \left(\sqrt{4t_{il}^2 + \left(2 + \frac{1}{\beta}\right)t_b^2 + (2 + \beta)t_r^2 + 4t_{il}(t_b + t_r) + 2t_b t_r - 2t_{il} - t_b - t_r} \right) + \frac{F_{ax,Rk}}{4} \\ 1,05 \cdot \frac{f_{h,b,k} \cdot d \cdot \beta}{\frac{1}{2} + \beta} \left(\sqrt{t_{il}^2 + t_{il}t_b + \frac{t_b^2}{2} \left(1 + \frac{1}{\beta}\right) + \frac{M_{y,k}}{f_{h,b,k}d} \left(1 + \frac{2}{\beta}\right)} - t_{il} - \frac{t_b}{2} \right) + \frac{F_{ax,Rk}}{4} \\ 1,05 \cdot \frac{f_{h,b,k} \cdot d \cdot \beta}{\frac{1}{2} + \beta} \left(\sqrt{t_{il}^2 + t_{il}t_r + \frac{t_r^2}{2} (1 + \beta) + \frac{M_{y,k}}{f_{h,b,k}d} \left(2 + \frac{1}{\beta}\right)} - t_{il} - \frac{t_r}{2} \right) + \frac{F_{ax,Rk}}{4} \\ 1,15 \cdot \frac{f_{h,b,k} \cdot d}{1 + \beta} \left(\sqrt{\beta^2 t_{il}^2 + 4\beta(\beta + 1) \cdot \frac{M_{y,k}}{f_{h,b,k}d}} - \beta t_{il} \right) + \frac{F_{ax,Rk}}{4} \end{array} \right.$$

mit :

$f_{h,b,k}$	Charakteristische Lochleibungsfestigkeit der Konterlatte [N/mm ²]
$f_{h,r,k}$	Charakteristische Lochleibungsfestigkeit des Sparrens [N/mm ²]
β	$f_{h,r,k}/f_{h,b,k}$
d	Gewindeaußendurchmesser der Schraube [mm]
t_b	Lattendicke [mm]
t_r	Niedrigster Wert aus Sparrendicke oder Einbindetiefe der Schraube [mm]
t_{il}	Zwischenschichtdicke [mm]
$M_{y,k}$	Charakteristisches Fließmoment [Nmm]
$F_{ax,Rk}$	Maßgebende charakteristische Zugtragfähigkeit der Schraube [N]

fischer Power-Fast und Holzbauschrauben	
Bemessung	

Mindestrand- und Achsabstände

Schrauben unter Axial- oder Querbelastung in der Seitenfläche oder Schmalfläche von Brettsper Holz

Definition von Achs- und Randabständen sowie der Abstände untereinander in der Seitenfläche, sofern in der technischen Spezifikation (ETA oder hEN) für Brettsper Holz nicht anderslautend angegeben:

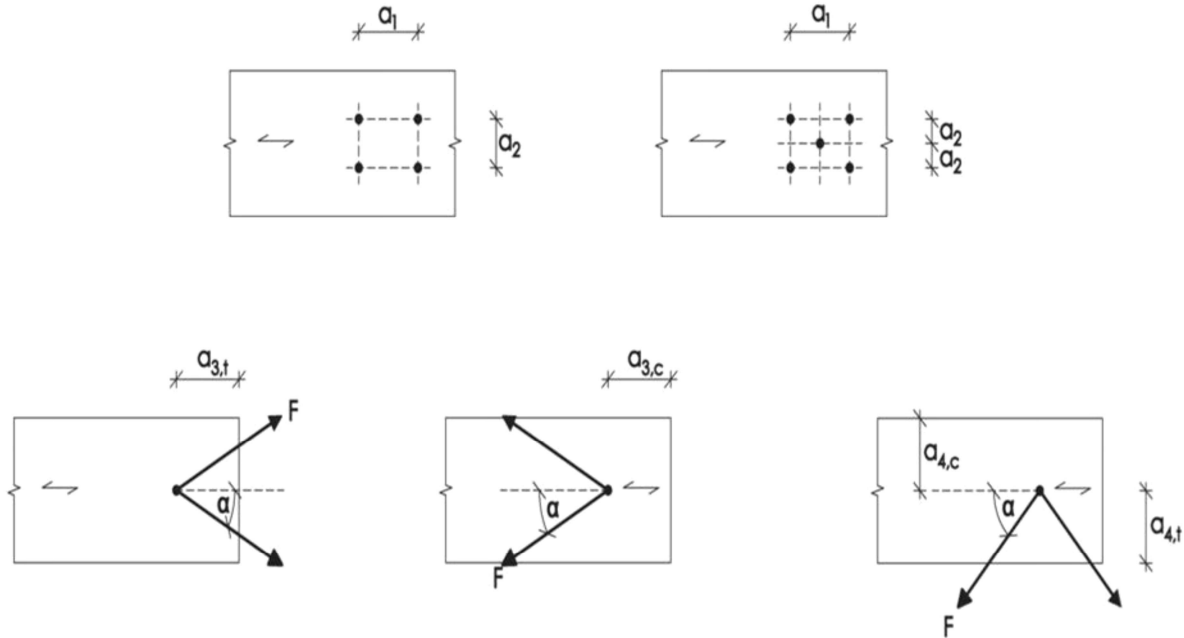

Definition von Achs- und Randabständen sowie der Abstände untereinander in der Schmalfläche, sofern in der technischen Spezifikation (ETA oder hEN) für Brettsper Holz nicht anderslautend angegeben:

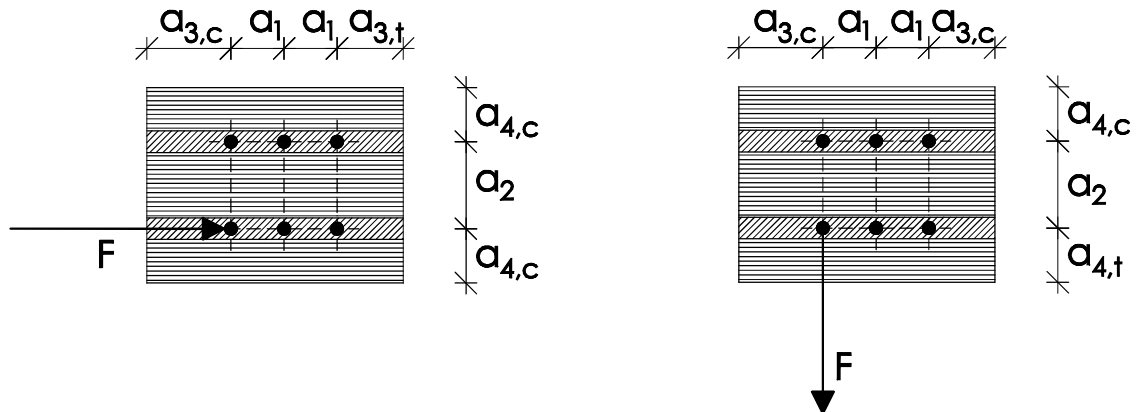

Bei Verschraubungen in den Schmalflächen sind a_1 und a_3 parallel zur Seitenfläche des Brettsper Holzes, a_2 und a_4 rechtwinklig zur Seitenfläche des Brettsper Holzes angeordnet.

Tabelle C1: Minimaler Achs- und Randabstand der Schrauben in den Seiten- und Schmalflächen von Brettsper Holz

	a_1	$a_{3,t}$	$a_{3,c}$	a_2	$a_{4,t}$	$a_{4,c}$
Seitenflächen (siehe Abb. 1)	$4 \cdot d$	$6 \cdot d$	$6 \cdot d$	$2,5 \cdot d$	$6 \cdot d$	$2,5 \cdot d$
Schmalflächen (siehe Abb. 2)	$10 \cdot d$	$12 \cdot d$	$7 \cdot d$	$4 \cdot d$	$6 \cdot d$	$3 \cdot d$

fischer Power-Fast und Holzbauschrauben	
Mindestrand- und Achsabstände	

Schematische Darstellung der Kopfeinspannung der Power-Fast-Schrauben

Metrische Schrauben mit Sechskantkopf, Senkkopf oder Zylinderkopf sowie Gewindestangen mit Mutter und U-Scheibe – jeweils nach statischer Anforderung – mindestens 2xM8 (≥ 4.6 bzw. A2-50) zur Verbindung der beiden Platten aus Aluminium (Festigkeitseigenschaften mindestens wie z.B. EN AW 6082, EN AW 5083, EN AW 6060 oder EN AC-44100); aus Stahl oder aus nicht rostendem Stahl (jeweils mindestens S235).

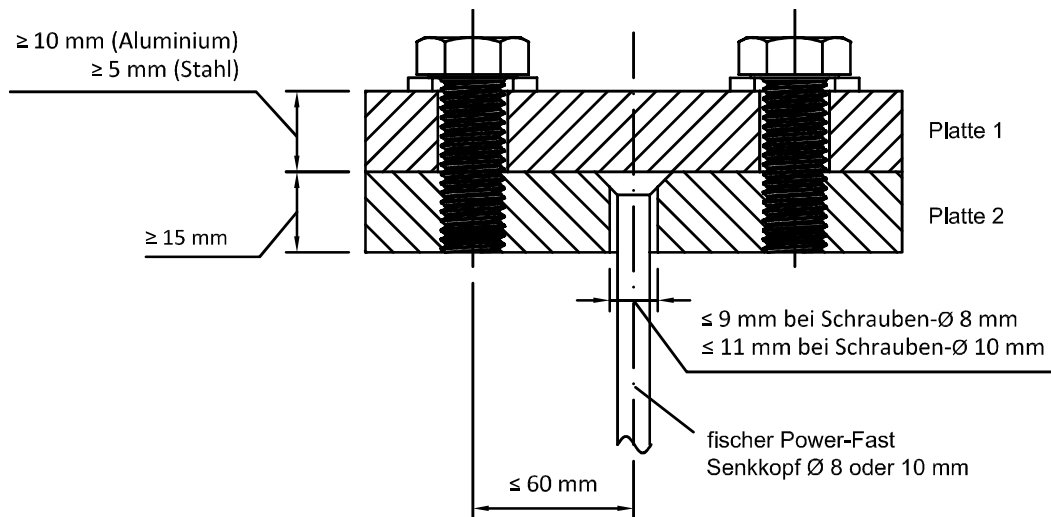

Angaben für die Nachweise der metrischen Schraubverbindung, sowie der beiden Platten sind nicht Bestandteil dieser Europäischen Technischen Bewertung.

(Abb. nicht maßstäblich)

fischer Power-Fast und Holzbauschrauben	
Kopfeinspannung bei Druckbeanspruchung	



DECLARATION OF PERFORMANCE

DoP: 0154

for fischer Power-Fast screws and fischer construction screws (Screws for use in timber constructions) – EN

1. Unique identification code of the product-type: **DoP: 0154**
2. Intended use/es: **For connections in load bearing timber constructions or for fixing of thermal insulation on rafters**
3. Manufacturer: **fischerwerke GmbH & Co. KG, Klaus-Fischer-Straße 1, 72178 Waldachtal, Germany**
4. Authorised representative: --
5. System/s of AVCP: **3**
6. European Assessment Document: **EAD 130118-00-0603**
European Technical Assessment: **ETA-11/0027; 2019-01-02**
Technical Assessment Body: **ETA-Danmark A/S**
Notified body/ies: **1343 – MPA Darmstadt**
7. Declared performance/s:

Mechanical resistance and stability (BWR 1), Safety in use (BWR 4)

Tensile strength	Characteristic value $f_{tens,k}$:
Screws made of carbon steel	Screw d = 3,0 mm: 2,7 kN Screw d = 3,5 mm: 3,7 kN Screw d = 4,0 mm: 4,8 kN Screw d = 4,5 mm: 6,0 kN Screw d = 5,0 mm: 7,5 kN Screw d = 6,0 mm: 10,7 kN Screw d = 8,0 mm: 19,1 kN Screw d = 10,0 mm: 29,8 kN Screw d = 12,0 mm: 32,7 kN
Screws made of stainless steel	Screw d = 3,0 mm: 1,6 kN Screw d = 3,5 mm: 2,1 kN Screw d = 4,0 mm: 2,8 kN Screw d = 4,5 mm: 3,5 kN Screw d = 5,0 mm: 4,3 kN Screw d = 6,0 mm: 6,2 kN Screw d = 8,0 mm: 13,0 kN
Insertion moment	Ratio of the characteristic torsional strength to the mean insertion moment: $f_{tor,k} / R_{tor,mean} \geq 1,5$
Torsional strength	Characteristic value $f_{tor,k}$:
Screws made of carbon steel	Screw d = 3,0 mm: 1,3 Nm Screw d = 3,5 mm: 2,0 Nm Screw d = 4,0 mm: 3,0 Nm Screw d = 4,5 mm: 4,3 Nm Screw d = 5,0 mm: 6,0 Nm Screw d = 6,0 mm: 9,5 Nm Screw d = 8,0 mm: 25,0 Nm Screw d = 10,0 mm: 40,0 Nm Screw d = 12,0 mm: 55,0 Nm

Screws made of stainless steel

Screw d = 3,0 mm: 0,9 Nm
Screw d = 3,5 mm: 1,3 Nm
Screw d = 4,0 mm: 1,9 Nm
Screw d = 4,5 mm: 2,6 Nm
Screw d = 5,0 mm: 3,7 Nm
Screw d = 6,0 mm: 6,5 Nm
Screw d = 8,0 mm: 16,0 Nm

Safety in case of fire (BWR 2)

- **Reaction to fire: Anchorages satisfy requirements for Class A 1**

Sustainable use of natural resources (BWR 7)

NPD

8. Appropriate Technical Documentation and/or Specific Technical Documentation: ---

The performance of the product identified above is in conformity with the set of declared performance/s. This declaration of performance is issued, in accordance with Regulation (EU) No 305/2011, under the sole responsibility of the manufacturer identified above.

Signed for and on behalf of the manufacturer by:

Andreas Bucher, Dipl.-Ing.

Wolfgang Hengesbach, Dipl.-Ing., Dipl.-Wirtsch.-Ing.

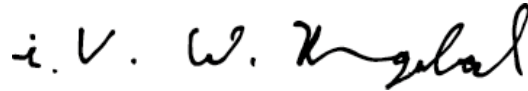

Tumlingen, 2019-01-09

- This DoP has been prepared in different languages. In case there is a dispute on the interpretation the english version shall always prevail.
- The Appendix includes voluntary and complementary information in English language exceeding the (language-neutrally specified) legal requirements.



ETA-Danmark A/S
Göteborg Plads 1
DK-2150 Nordhavn
Tel. +45 72 24 59 00
Fax +45 72 24 59 04
Internet www.etadanmark.dk

Appendix 1/41
Authorised and notified according
to Article 29 of the Regulation (EU)
No 305/2011 of the European
Parliament and of the Council of 9
March 2011

MEMBER OF EOTA



European Technical Assessment ETA-11/0027 of 2019/01/02

I General Part

Technical Assessment Body issuing the ETA and designated according to Article 29 of the Regulation (EU) No 305/2011: ETA-Danmark A/S

Trade name of the construction product:

fischer Power-Fast screws and fischer construction screws

Product family to which the above construction product belongs:

Screws for use in timber constructions

Manufacturer:

fischerwerke GmbH & Co. KG
Klaus-Fischer-Str. 1
72178 Waldachtal
GERMANY

Manufacturing plant:

fischerwerke

This European Technical Assessment contains:

41 pages including 4 annexes which form an integral part of the document

This European Technical Assessment is issued in accordance with Regulation (EU) No 305/2011, on the basis of:

European Assessment document (EAD) no. EAD 130118-00-0603 "Screws for timber constructions"

This version replaces:

The previous ETA with the same number issued on 2013-06-26 and expiry on 2018-06-26

Translations of this European Technical Assessment in other languages shall fully correspond to the original issued document and should be identified as such.

Communication of this European Technical Assessment, including transmission by electronic means, shall be in full (excepted the confidential Annex(es) referred to above). However, partial reproduction may be made, with the written consent of the issuing Technical Assessment Body. Any partial reproduction has to be identified as such.

II SPECIFIC PART OF THE EUROPEAN TECHNICAL ASSESSMENT

1 Technical description of product and intended use

Technical description of the product

“fischer Power-Fast” and “fischer construction screws” are self-tapping screws to be used in timber structures. “fischer Power-Fast” screws shall be threaded over a part or over the full length. “fischer construction screws” shall be threaded over a part of the length. The screws shall be produced from carbon steel wire for nominal diameters of 3,0 mm to 12,0 mm and from stainless steel wire for nominal diameters of 3,0 mm to 8,0 mm. The material specification of the stainless steel screws is deposited with ETA-Danmark. Where corrosion protection is required, the material or coating shall be declared in accordance with the relevant specification given in Annex A of EN 14592.

Geometry and Material

The nominal diameter (outer thread diameter), d , shall not be less than 3,0 mm and shall not be greater than 12,0 mm. The overall length, L , of screws shall not be less than 20 mm and shall not be greater than 600 mm. Other dimensions are given in Annex A1 to Annex A19.

The ratio of inner thread diameter to outer thread diameter d_i/d ranges from 0,59 to 0,69.

The screws are threaded over a minimum length ℓ_g of $4,0 \cdot d$ (i.e. $\ell_g \geq 4,0 \cdot d$).

The lead p (distance between two adjacent thread flanks) ranges from $0,50 \cdot d$ to $0,67 \cdot d$.

No breaking of screws shall be observed at a bend angle, α , of less than $(45/d^{0,7} + 20)$ degrees.

The material specification of the of the stainless steel screws is deposited with ETA-Danmark.

2 Specification of the intended use in accordance with the applicable EAD

The screws are used for connections in load bearing timber structures between members of solid timber (softwood and hardwood). Furthermore, all kinds of processed timber products (all softwood and hardwood as well), such as glued laminated timber, cross-laminated timber, laminated veneer lumber, similar glued members, wood-based panels or steel.

Furthermore “fischer Power-Fast” screws with diameter of 6 mm, 8 mm, 10 mm and 12 mm may also be used for the fixing of heat insulation on rafters and on vertical facades.

Steel plates and wood-based panels except solid wood panels, Egger OSB Eurostrand 4 TOP and cross laminated timber shall only be located on the side of the screw head. The following wood-based panels may be used:

- Plywood according to EN 636 or ETA
- Particleboard according to EN 312 or ETA
- Oriented Strand Board, Type OSB/3 and OSB/4 according to EN 300 or ETA
- Fibreboard according to EN 622-2 and 622-3 or ETA (minimum density 650 kg/m³)
- Cement bonded particleboard according to ETA
- Solid wood panels according to EN 13353 and EN 13986, and cross laminated timber according to ETA
- Laminated Veneer Lumber according to EN 14374 or ETA
- Engineered wood products according to ETA if the ETA of the product includes provisions for the use of self-tapping screws, the provisions of the ETA of the engineered wood product apply

The screws shall be screwed into softwood without pre-drilling or after pre-drilling with a diameter not larger than the inner thread diameter for the length of the threaded part and with a maximum of the smooth shank diameter for the length of the smooth shank. The screws shall be driven into hardwood after pre-drilling with a suitable diameter according to section 3.11.

The screws are intended to be used in timber connections for which requirements for mechanical resistance and stability and safety in use in the sense of the Basic Works Requirements 1 and 4 of Regulation 305/2011 shall be fulfilled.

Form and dimensions of washers are given in Annex A20. Washers must be made of steel.

The design of the connections shall be based on the characteristic load-carrying capacities of the screws. The design capacities shall be derived from the characteristic capacities in accordance with Eurocode 5 or an appropriate national code (e.g. DIN 1052:2008-12). Regarding environmental conditions, national provisions at the building site shall apply.

The screws are intended for use for connections subject to static or quasi static loading.

The zinc-coated screws are for use in timber structures subject to the dry, internal conditions defined by the

service classes 1 and 2 of EN 1995-1-1:2008 (Eurocode 5).

The screws made of stainless steel meet the requirements of Eurocode 5 (EN 1995-1-1:2008), for use in structures subject to the wet conditions defined as service class 3.

The scope of the screws regarding resistance to corrosion shall be defined according to national provisions that apply at the installation site considering environmental conditions.

The provisions made in this European Technical Assessment are based on an assumed intended working life of the screws of 50 years.

The indications given on the working life cannot be interpreted as a guarantee given by the producer or Assessment Body, but are to be regarded only as a means for choosing the right products in relation to the expected economically reasonable working life of the works.

3 Performance of the product and references to the methods used for its assessment

Characteristic	Assessment of characteristic
3.1 Mechanical resistance and stability*) (BWR1)	
Tensile strength	Characteristic value $f_{\text{tens},k}$:
Screws made from carbon steel	Screw d = 3,0 mm: 2,7 kN Screw d = 3,5 mm: 3,7 kN Screw d = 4,0 mm: 4,8 kN Screw d = 4,5 mm: 6,0 kN Screw d = 5,0 mm: 7,5 kN Screw d = 6,0 mm: 10,7 kN Screw d = 8,0 mm: 19,1 kN Screw d = 10,0 mm: 29,8 kN Screw d = 12,0 mm: 32,7 kN
Screws from stainless steel	Screw d = 3,0 mm: 1,6 kN Screw d = 3,5 mm: 2,1 kN Screw d = 4,0 mm: 2,8 kN Screw d = 4,5 mm: 3,5 kN Screw d = 5,0 mm: 4,3 kN Screw d = 6,0 mm: 6,2 kN Screw d = 8,0 mm: 13,0 kN
Insertion moment	Ratio of the characteristic torsional strength to the mean insertion moment: $f_{\text{tor},k} / R_{\text{tor,mean}} \geq 1,5$
Torsional strength	Characteristic value $f_{\text{tor},k}$:
Screws from carbon steel	Screw d = 3,0 mm: 1,3 Nm Screw d = 3,5 mm: 2,0 Nm Screw d = 4,0 mm: 3,0 Nm Screw d = 4,5 mm: 4,3 Nm Screw d = 5,0 mm: 6,0 Nm Screw d = 6,0 mm: 9,5 Nm Screw d = 8,0 mm: 25,0 Nm Screw d = 10,0 mm: 40,0 Nm Screw d = 12,0 mm: 55,0 Nm
Screws from stainless steel	Screw d = 3,0 mm: 0,9 Nm Screw d = 3,5 mm: 1,3 Nm Screw d = 4,0 mm: 1,9 Nm Screw d = 4,5 mm: 2,6 Nm Screw d = 5,0 mm: 3,7 Nm Screw d = 6,0 mm: 6,5 Nm Screw d = 8,0 mm: 16,0 Nm
3.2 Safety in case of fire (BWR2)	
Reaction to fire	The screws are made from steel classified as Euroclass A1 in accordance with EN 13501-1 and Commission Delegated Regulation 2016/364.

Characteristic	Assessment of characteristic
3.7 Sustainable use of natural resources (BR7)	No Performance Assessed
3.8 General aspects related to the performance of the product	The screws have been assessed as having satisfactory durability and serviceability when used in timber structures using the timber species described in Eurocode 5 and subject to the conditions defined by service classes 1, 2 and 3
Identification	See Annex A

*) See additional information in section 3.9 – 3.12.

**) In addition to the specific clauses relating to dangerous substances contained in this European technical Assessment, there may be other requirements applicable to the products falling within its scope (e.g. transposed European legislation and national laws, regulations and administrative provisions). In order to meet the provisions of the Construction Products Regulation, these requirements need also to be complied with, when and where they apply.

3.9 Mechanical resistance and stability

The load-carrying capacities for “fischer Power-Fast” and “fischer construction screws” are applicable to the wood-based materials mentioned in paragraph 1 even though the term timber has been used in the following.

The characteristic lateral load-carrying capacities and the characteristic axial withdrawal capacities of “fischer Power-Fast” and “fischer construction screws” screws should be used for designs in accordance with Eurocode 5 or an appropriate national code.

Pointside penetration length of the threaded part must be $\ell_{ef} \geq 4 \cdot d$, where d is the outer thread diameter of the screw. For the fixing of rafters, point side penetration must be at least 40 mm, $\ell_{ef} \geq 40$ mm.

ETA’s for structural members may be considered if applicable.

For wood-based panels the relevant ETAs must be considered where applicable.

Lateral load-carrying capacity

The characteristic lateral load-carrying capacity of “fischer Power-Fast” and “fischer construction screws” screws shall be calculated according to EN 1995-1-1:2008 (Eurocode 5) using the outer thread diameter d as the nominal diameter of the screw. The contribution from the rope effect may be considered.

The characteristic yield moment shall be calculated from:

Screws from carbon steel for $3,0 \text{ mm} \leq d \leq 5,0 \text{ mm}$ and $12,0 \text{ mm}$:

$$M_{y,k} = 0,15 \cdot 500 \text{ (N/mm}^2\text{)} \cdot d^{2,6} \quad [\text{Nmm}]$$

Screws from carbon steel for $6,0 \text{ mm} \leq d \leq 10,0 \text{ mm}$:

$$M_{y,k} = 0,15 \cdot 600 \text{ (N/mm}^2\text{)} \cdot d^{2,6} \quad [\text{Nmm}]$$

Screws from stainless steel for $3,0 \text{ mm} < d < 6,0 \text{ mm}$:

$$M_{y,k} = 0,15 \cdot 350 \text{ (N/mm}^2\text{)} \cdot d^{2,6} \quad [\text{Nmm}]$$

Screws from stainless steel for $d = 8,0 \text{ mm}$:

$$M_{y,k} = 0,15 \cdot 400 \text{ (N/mm}^2\text{)} \cdot d^{2,6} \quad [\text{Nmm}]$$

where

d outer thread diameter [mm]

The embedding strength for screws in non-pre-drilled holes arranged at an angle between screw axis and grain direction, $0^\circ \leq \alpha \leq 90^\circ$ is:

$$f_{h,k} = \frac{0,082 \cdot \rho_k \cdot d^{-0,3}}{2,5 \cdot \cos^2 \alpha + \sin^2 \alpha} \quad [\text{N/mm}^2]$$

and accordingly, for screws in pre-drilled holes:

$$f_{h,k} = \frac{0,082 \cdot \rho_k \cdot (1 - 0,01 \cdot d)}{2,5 \cdot \cos^2 \alpha + \sin^2 \alpha} \quad [\text{N/mm}^2]$$

Where

ρ_k characteristic timber density [kg/m^3];

d outer thread diameter [mm];

α angle between screw axis and grain direction.

The embedding strength for screws arranged parallel to the plane surface of cross laminated timber, independent of the angle between screw axis and grain direction, $0^\circ \leq \alpha \leq 90^\circ$, may be calculated from:

$$f_{h,k} = 20 \cdot d^{-0,5} \quad [\text{N/mm}^2]$$

Where

d outer thread diameter [mm]

The embedding strength for screws in the plane surface of cross laminated timber should be assumed as for solid timber based on the characteristic density of the outer layer. If relevant, the angle between force and grain direction of the outer layer should be taken into account.

The direction of the lateral force shall be perpendicular to the screw axis and parallel to the plane surface of the cross laminated timber.

Axial withdrawal capacity

The characteristic axial withdrawal capacity of „fischer Power-Fast” and “fischer construction screws” in solid timber (softwood and ash, beech or oak hardwood), glued laminated timber (softwood and hardwood, ash, beech or oak), laminated veneer lumber (softwood or hardwood beech) or cross-laminated timber members at an angle of $0^\circ \leq \alpha \leq 90^\circ$ to the grain or in Egger Eurostrand OSB 4 TOP at an angle of $\alpha = 90^\circ$ to the panel surface shall be calculated from:

$$F_{ax,\alpha,Rk} = n_{ef} \cdot k_{ax} \cdot f_{ax,k} \cdot d \cdot \ell_{ef} \cdot \left(\frac{\rho_k}{350} \right)^{0,8} \quad [\text{N}]$$

Where

$F_{ax,\alpha,Rk}$ Characteristic withdrawal capacity of the connection at an angle α to the grain [N]

n_{ef} Effective number of screws according to EN 1995-1-1

For inclined screws: $n_{ef} = \max \{ n^{0,9}; 0,9 \cdot n \}$

k_{ax} Factor, taking into account the angle α between screw axis and grain direction
 $k_{ax} = 1,0$ for $45^\circ \leq \alpha < 90^\circ$

$k_{ax} = 0,3 + \frac{0,7 \cdot \alpha}{45}$ for $0^\circ \leq \alpha < 45^\circ$

jointed beams or columns or for the fixing of thermal insulation material, $n_{ef} = n$.

$f_{ax,k}$	Characteristic withdrawal parameter [N/mm ²] for timber members
screw d = 3,0 mm:	$f_{ax,k} = 13,8 \text{ N/mm}^2$
screw d = 3,5 mm:	$f_{ax,k} = 13,4 \text{ N/mm}^2$
screw d = 4,0 mm:	$f_{ax,k} = 13,0 \text{ N/mm}^2$
screw d = 4,5 mm:	$f_{ax,k} = 12,6 \text{ N/mm}^2$
screw d = 5,0 mm:	$f_{ax,k} = 12,2 \text{ N/mm}^2$
screw d = 6,0 mm:	$f_{ax,k} = 11,6 \text{ N/mm}^2$
screw d ≥ 8,0 mm:	$f_{ax,k} = 10,0 \text{ N/mm}^2$

for Egger Eurostrand OSB 4 TOP with minimum thickness t = 12 mm:

screw 5,0 mm ≤ d ≤ 10,0 mm:
 $f_{ax,k} = 10,0 \text{ N/mm}^2$

d	Outer thread diameter [mm]
ℓ_{ef}	Point side penetration length of the threaded part according to EN 1995-1-1:2008 [mm]
α	Angle between grain and screw axis [°]
ρ_k	Characteristic density [kg/m ³], for hardwoods the assumed characteristic density shall not exceed 730 kg/m ³

For screws arranged under an angle between screw axis and grain direction of less than 90°, the minimum threaded penetration length is:

$$\ell_{ef} \geq \min(4 \cdot d / \sin \alpha ; 20 \cdot d)$$

For screws penetrating more than one layer of cross laminated timber, the different layers may be taken into account proportionally.

The axial withdrawal capacity is limited by the head pull-through capacity and the tensile strength of the screw.

For axially loaded screws in tension, where the external force is parallel to the screw axes, the rules in EN 1995-1-1, 8.7.2 (8) should be applied.

For inclined screws in timber-to-timber or steel-to-timber shear connections, where the screws are arranged under an angle $30^\circ \leq \alpha \leq 60^\circ$ between the shear plane and the screw axis, the effective number of screws n_{ef} should be determined as follows:

For one row of n screws parallel to the load, the load-carrying capacity should be calculated using the effective number of fasteners n_{ef} , where

$$n_{ef} = \max\{n^{0,9} ; 0,9 \cdot n\}$$

and n is the number of inclined screws in a row. If crossed pairs of screws are used in timber-to-timber connections, n is the number of crossed pairs of screws in a row.

Note: For inclined screws as fasteners in mechanically

Head pull-through capacity

The characteristic head pull-through capacity of “fischer Power-Fast” and “fischer construction screws” shall be calculated according to EN 1995-1-1:2008 from:

$$F_{ax,\alpha,Rk} = n_{ef} \cdot f_{head,k} \cdot d_h^2 \cdot \left(\frac{\rho_k}{350}\right)^{0,8} \quad [N]$$

where:

$F_{ax,\alpha,Rk}$	characteristic head pull-through capacity of the connection at an angle $\alpha \geq 30^\circ$ to the grain [N]
n_{ef}	effective number of screws according to EN 1995-1-1 For inclined screws: $n_{ef} = \max\{n^{0,9} ; 0,9 \cdot n\}$ (see axial withdrawal capacity)
$f_{head,k}$	characteristic head pull-through parameter [N/mm ²]
d_h	diameter of the screw head [mm]
ρ_k	characteristic density [kg/m ³], for wood-based panels $\rho_k = 380 \text{ kg/m}^3$

Characteristic head pull-through parameter for screws with head diameter ≤ 21 mm in connections with timber and with wood-based panels with thicknesses above 20 mm:

$$f_{head,k} = 12 \text{ N/mm}^2$$

Characteristic head pull-through parameter for screws with head diameter 21 mm < $d_h \leq 35$ mm in connections with timber and with wood-based panels with thicknesses above 20 mm:

$$f_{head,k} = 10 \text{ N/mm}^2$$

Characteristic head pull-through parameter for screws in connections with wood-based panels with thicknesses between 12 mm and 20 mm:

$$f_{head,k} = 8 \text{ N/mm}^2$$

Screws in connections with wood-based panels with a thickness below 12 mm (minimum thickness of the wood based panels of 1,2·d with d as outer thread diameter):

$$f_{head,k} = 8 \text{ N/mm}^2$$

limited to $F_{ax,\alpha,Rk} = 400 \text{ N}$

The head diameter d_h shall be greater than 1,8· d_s , where d_s is the smooth shank or the wire diameter. Otherwise the characteristic head pull-through capacity $F_{ax,\alpha,Rk} = 0$.

Outer diameter of washers $d_h > 35$ mm shall not be considered.

The minimum thickness of wood-based panels according to the clause 3.9 must be observed.

In steel-to-timber connections the head pull-through capacity is not decisive.

Tensile capacity

The characteristic tensile strength $f_{\text{tens},k}$ of “fischer Power-Fast” and “fischer construction screws” is:

Screws from carbon steel:

Screw d = 3,0 mm:	2,7 kN
Screw d = 3,5 mm:	3,7 kN
Screw d = 4,0 mm:	4,3 kN
Screw d = 4,5 mm:	5,5 kN
Screw d = 5,0 mm:	6,8 kN
Screw d = 6,0 mm:	10,7 kN
Screw d = 8,0 mm:	19,1 kN
Screw d = 10,0 mm:	29,8 kN
Screw d = 12,0 mm:	32,7 kN

Screws from stainless steel:

Screw d = 3,0 mm:	1,6 kN
Screw d = 3,5 mm:	2,1 kN
Screw d = 4,0 mm:	2,8 kN
Screw d = 4,5 mm:	3,5 kN
Screw d = 5,0 mm:	4,3 kN
Screw d = 6,0 mm:	6,2 kN
Screw d = 8,0 mm:	13,0 kN

For screws used in combination with steel plates, the tear-off capacity of the screw head should be greater than the tensile strength of the screw.

Compressive capacity

The characteristic compressive capacity $F_{\text{ax},Rk}$ of fischer Power-Fast screws with the head fixed between two aluminium-, carbon steel- or stainless steel plates according to Annex D and the thread driven completely into timber perpendicular to the grain shall be calculated from:

$$F_{\text{ax},Rk} = \min \left\{ f_{\text{ax},k} \cdot d \cdot \ell_{\text{ef}} \cdot \left(\frac{\rho_k}{350} \right)^{0,8} ; \kappa_c \cdot N_{\text{pl},k} \right\} [\text{N}]$$

Where

$$\kappa_c = \begin{cases} 1 & \text{for } \bar{\lambda}_k \leq 0,2 \\ \frac{1}{k + \sqrt{k^2 - \bar{\lambda}_k^2}} & \text{for } \bar{\lambda}_k > 0,2 \end{cases}$$

$$k = 0,5 \cdot \left[1 + 0,49 \cdot (\bar{\lambda}_k - 0,2) + \bar{\lambda}_k^2 \right]$$

The relative slenderness ratio shall be calculated from:

$$\bar{\lambda}_k = \sqrt{\frac{N_{\text{pl},k}}{N_{\text{ki},k}}}$$

Where

$$N_{\text{pl},k} = \pi \cdot \frac{d_s^2}{4} \cdot f_{y,k} \quad [\text{N}]$$

is the characteristic value for the axial capacity in case of plastic analysis referred to the smooth shank cross-section.

$$N_{\text{ki},k} = \frac{\pi^2 \cdot EI_s}{\ell_{\text{ef}}^2} \quad [\text{N}]$$

is the characteristic ideal elastic buckling load.

Characteristic yield strength for screws made of carbon steel:

$$f_{y,k} = 1000 \quad [\text{N/mm}^2]$$

Characteristic yield strength for screws made of stainless steel:

$$f_{y,k} = 500 \quad [\text{N/mm}^2]$$

Modulus of elasticity for screws made of carbon steel:

$$E_s = 210000 \quad [\text{N/mm}^2]$$

Modulus of elasticity for screws made of stainless steel:

$$E_s = 160000 \quad [\text{N/mm}^2]$$

Second moment of area:

$$I_s = \frac{\pi}{64} \cdot d_s^4 \quad [\text{mm}^4]$$

d_s = smooth shank diameter [mm]

$\ell_{\text{ef}} = 0,7 \cdot \ell$ buckling length [mm]

ℓ = free screw length protruding from the timber member including the screw head [mm]

Note: When determining design values of the compressive capacity it should be considered that $f_{\text{ax},d}$ is to be calculated using k_{mod} and γ_M for timber according to EN 1995 while $N_{\text{pl},d}$ is calculated using $\gamma_{M,1}$ for steel buckling according to EN 1993.

Combined laterally and axially loaded screws

For screwed connections subjected to a combination of axial load and lateral load, the following expression should be satisfied:

$$\left(\frac{F_{\text{ax},Ed}}{F_{\text{ax},Rd}} \right)^2 + \left(\frac{F_{\text{la},Ed}}{F_{\text{la},Rd}} \right)^2 \leq 1$$

where

$F_{\text{ax},Ed}$ axial design load of the screw

$F_{\text{la},Ed}$ lateral design load of the screw

$F_{\text{ax},Rd}$ design load-carrying capacity of an axially loaded screw

$F_{\text{la},Rd}$ design load-carrying capacity of a laterally loaded screw

Slip modulus

The axial slip modulus K_{ser} of a screw for the serviceability limit state should be taken independent of angle α to the grain as:

$$C = K_{\text{ser}} = 780 \cdot d^{0,2} \cdot \ell_{\text{ef}}^{0,4} \quad [\text{N/mm}]$$

Where

d outer thread diameter [mm]

ℓ_{ef} penetration length in the structural member [mm]

Thermal insulation material on top of rafters

“fischer Power-Fast” screws with an outer thread diameter of $d = 6$ mm, 8 mm, 10 mm and 12 mm may be used for the fixing of thermal insulation material on top of rafters.

The thickness of the insulation ranges up to 400 mm. The rafter insulation must be placed on top of solid timber or glued laminated timber rafters or cross-laminated timber members and be fixed by battens placed parallel to the rafters or by wood-based panels on top of the insulation layer. The insulation of vertical facades is also covered by the rules given here.

Screws must be screwed in the rafter through the battens or panels and the insulation without pre-drilling in one sequence.

The angle α between the screw axis and the grain direction of the rafter should be between 30° and 90° .

The battens must be from solid timber (softwood) according to EN 338:2003-04. The minimum thickness of the battens is 80 mm and the minimum width 100 mm for screws with outer thread diameter $d = 12$ mm. The minimum thickness of the battens is 40 mm and the minimum width 60 mm for screws with outer thread diameter $d = 10$ mm. For screws with outer thread diameter $d = 6$ mm and 8 mm the minimum thickness of the battens is 30 mm and the minimum width 50 mm.

Alternatively, to the battens, boards with a minimum thickness of 20 mm from plywood according to EN 636, particle board according to EN 312, oriented strand board OSB/3 and OSB/4 according to EN 300 or ETA and solid wood panels according to EN 13353 may be used.

The rafter consists of solid timber (softwood) according to EN 338, glued laminated timber according to EN 14081, cross-laminated timber, laminated veneer lumber according to EN 14374 or to ETA or similar glued members according to ETA and has a minimum width of 60 mm.

The insulation must comply with a ETA.

The insulation must have a minimum compressive stress of $\sigma_{10\%} = 0,05$ N/mm² at 10 % deformation according to EN 826:1996-05.

The analysis of the fixing of the insulation and battens or boards, respectively, may be carried out using the static model in Annex B. The battens or boards, respectively, must have sufficient strength and stiffness. The maximum pressure between the battens or boards, respectively, and the insulation shall not exceed $1,1 \cdot \sigma_{10\%}$.

The characteristic axial withdrawal capacity of the screws for rafter or facade insulation shall be calculated from:

$$F_{ax,\alpha,Rk} = \min \begin{cases} k_{ax} \cdot f_{ax,k} \cdot d \cdot \ell_{ef} \cdot k_1 \cdot k_2 \left(\frac{\rho_k}{350} \right)^{0,8} \\ f_{head,k} \cdot d_h^2 \cdot \left(\frac{\rho_k}{350} \right)^{0,8} \\ f_{tens,d} \end{cases} \quad [N]$$

where

$F_{ax,\alpha,Rk}$	Characteristic withdrawal capacity of the connection at an angle α to the grain [N]
k_{ax}	Factor, taking into account the angle α between screw axis and grain direction $k_{ax} = 1,0$ for $45^\circ \leq \alpha < 90^\circ$ $k_{ax} = 0,3 + \frac{0,7 \cdot \alpha}{45}$ for $0^\circ \leq \alpha < 45^\circ$
$f_{ax,k}$	Characteristic withdrawal parameter [N/mm ²]
D	Outer thread diameter [mm]
ℓ_{ef}	Point side penetration length of the threaded part according to EN 1995-1-1:2008 [mm]
α	Angle between grain and screw axis ($\alpha \geq 30^\circ$)
k_1	$\min \{1; 220/t_{HI}\}$
k_2	$\min \{1; \sigma_{10\%}/0,12\}$
t_{HI}	Thickness of the thermal insulation [mm]
$\sigma_{10\%}$	Compressive stress of the thermal insulation under 10 % deformation [N/mm ²] $\sigma_{10\%} \geq 0,05$ N/mm ²
$f_{head,k}$	Characteristic head pull-through parameter [N/mm ²]
d_h	Outer diameter of the screw head [mm]
ρ_k	Characteristic density [kg/m ³]
$f_{tens,d}$	Characteristic tensile capacity of the screw [N]

Friction forces shall not be considered for the design of the characteristic axial withdrawal capacity of the screws.

The anchorage of wind suction forces as well as the bending stresses of the battens or the boards, respectively, shall be considered in design. Additional screws perpendicular to the grain of the rafter (angle $\alpha = 90^\circ$) may be arranged if necessary.

Screws for the anchorage of rafter insulation shall be arranged according to Annex B.

The maximum screw spacing is $e_s = 1,75$ m.

3.10 Aspects related to the performance of the product

3.10.1 Corrosion protection in service class 1, 2 and 3.

The fischer Power-Fast and fischer construction screws are produced from carbon wire. Screws made from carbon steel

are electrogalvanised and yellow or blue chromate. The mean thickness of the zinc coating is 5µm.

The material specification of the stainless steel screws is deposited with ETA-Danmark.

3.11 General aspects related to the intended use of the product

The screws are manufactured in accordance with the provisions of the European Technical Assessment using the automated manufacturing process and laid down in the technical documentation.

The installation shall be carried out in accordance with Eurocode 5 or an appropriate national code unless otherwise is defined in the following. Instructions from fischerwerke GmbH & Co. KG should be considered for installation.

The screws are used for connections in load bearing timber structures between members of solid timber (softwood and hardwood), glued laminated timber (softwood and hardwood), cross-laminated timber (minimum diameter $d = 6,0$ mm, softwood and hardwood)), laminated veneer lumber (softwood and hardwood), similar glued members (softwood and hardwood), wood-based panels or steel members.

The screws may be used for connections in load bearing timber structures with structural members according to an associated ETA, if according to the ETA of the structural member a connection in load bearing timber structures with screws according to an ETA is allowed.

Furthermore, the screws with diameters between 6 mm and 12 mm may also be used for the fixing of insulation on top of rafters or at vertical facades.

A minimum of two screws should be used for connections in load bearing timber structures. A single screw may be used in structural connections if the penetration length of the screw including an unthreaded part of the shank is at least $20 \cdot d$ and the screw is only axially loaded. The load-bearing capacity of the single screw in this case shall be reduced by 50 %.

A single screw per connection may also be used, if the member is fixed with at least two screws and the screws are used for the fixing of boards, battens and wind braces, or for the fixing of rafters, purlins or similar on main beams or top plates.

The minimum penetration depth in structural members made of solid, glued or cross-laminated timber is $4 \cdot d$.

Wood-based panels - except Egger Eurostrand OSB 4 TOP - and steel plates should only be arranged on the side of the

screw head. The minimum thickness of wood-based panels should be $1,2 \cdot d$. Furthermore, the minimum thickness for following wood-based panels should be:

- Plywood, Fibreboards: 6 mm
- Particleboards, OSB, Cement Particleboards: 8 mm
- Solid wood panels: 12 mm

For structural members according to ETA's the terms of the ETA's must be considered.

If screws with an outer thread diameter $d \geq 8$ mm are used in load bearing timber structures, the structural solid or glued laminated timber, laminated veneer lumber and similar glued members must be from spruce, pine or fir. This does not apply for screws in pre-drilled holes.

The minimum angle between the screw axis and the grain direction is $\alpha = 0^\circ$.

The screws shall be driven into softwood without predrilling or after pre-drilling. The screws shall be driven into hardwood with a maximum characteristic density of 730 kg/m^3 after predrilling.

The drill hole diameters are:

Outer thread diameter	Drill hole diameter	
	Softwood	Hardwood
4,0	2,5	3,0
4,5	2,5	3,0
5,0	3,0	3,0
6,0	4,0	4,0
8,0	5,0	6,0
10,0	6,0	7,0
12,0	7,0	8,0

The hole diameter in steel members must be predrilled with a suitable diameter.

Only the equipment prescribed by fischerwerke GmbH & Co. KG shall be used for driving the screws.

In connections with screws with countersunk head according to Annexes A1, A5, A6, A7, A11, A13 and A18, the head must be flush with the surface of the connected structural member. A deeper countersink is not allowed.

Screws from carbon steel and stainless steel with countersunk head according to Annex A1, A2, A5, A6, A7, A11, A13, A14 and A18 may be used together with washers according to Annex A20. Washers according to EN ISO 7094 may be used together with washers according to Annex A20.

Screws according to Annex A3, A4, A8, A9, A10, A12 A16, A17 and A19 may be used together with washers according to EN ISO 7094.

Washers from carbon steel should be used with screws from carbon steel and screws from stainless steel with washers from stainless steel. Washers should have a full bearing area.

For structural timber members, minimum spacing and distances for screws in predrilled holes are given in EN 1995-1-1:2008 (Eurocode 5) clause 8.3.1.2 and table 8.2 as for nails in predrilled holes. Here, the outer thread diameter d must be considered.

For screws in non-predrilled holes, minimum spacing and distances are given in EN 1995-1-1:2008 (Eurocode 5) clause 8.3.1.2 and table 8.2 as for nails in non-predrilled holes.

Alternatively, minimum distances and spacing for exclusively axially loaded "fischer Power-Fast" screws in non-predrilled holes in members of solid timber (softwood and hardwood), glued laminated timber or similar glued products (softwood and hardwood) with a minimum thickness $t = 12 \cdot d$ and a minimum width of $8 \cdot d$ or 60 mm, whichever is the greater, may be taken as:

Spacing a_1 parallel to the grain	$a_1 = 5 \cdot d$
Spacing a_2 perpendicular to the grain	$a_2 = 5 \cdot d$
Distance $a_{3,c}$ from centre of the screw-part in timber to the end grain	$a_{3,c} = 9 \cdot d$
Distance $a_{4,c}$ from centre of the screw-part in timber to the edge	$a_{4,c} = 4 \cdot d$

Spacing a_2 perpendicular to the grain may be reduced from $5 \cdot d$ to $2,5 \cdot d$, if the condition $a_1 \cdot a_2 \geq 25 \cdot d^2$ is fulfilled.

For Douglas fir members minimum spacing and distances parallel to the grain shall be increased by 50%.

Minimum distances from loaded or unloaded ends must be $15 \cdot d$ for screws in non-predrilled holes with outer thread diameter $d \geq 8$ mm and timber thickness $t < 5 \cdot d$.

Minimum distances from the unloaded edge perpendicular to the grain may be reduced to $3 \cdot d$ also for timber thickness $t < 5 \cdot d$, if the spacing parallel to the grain and the end distance is at least $25 \cdot d$.

Unless specified otherwise in the technical specification (ETA or hEN) of cross laminated timber, minimum distances and spacing for screws in the plane surface of cross laminated timber members with a minimum thickness $t = 10 \cdot d$ may be taken as (see Annex C):

Spacing a_1 parallel to the grain	$a_1 = 4 \cdot d$
Spacing a_2 perpendicular to the grain	$a_2 = 2,5 \cdot d$
Distance $a_{3,c}$ from centre of the screw-part in timber to the unloaded end grain of the plane surface	$a_{3,c} = 6 \cdot d$
Distance $a_{3,t}$ from centre of the screw-part in timber to the loaded end grain	

of the plane surface	$a_{3,t} = 6 \cdot d$
Distance $a_{4,c}$ from centre of the screw-part in timber to the unloaded edge	$a_{4,c} = 2,5 \cdot d$
Distance $a_{4,t}$ from centre of the screw-part in timber to the loaded edge	$a_{4,t} = 6 \cdot d$

Unless specified otherwise in the technical specification (ETA or hEN) of cross laminated timber, minimum distances and spacing for screws in the edge surface of cross laminated timber members with a minimum thickness $t = 10 \cdot d$ and a minimum penetration depth perpendicular to the edge surface of $10 \cdot d$ may be taken as (see Annex C):

Spacing a_1 parallel to the CLT plane surface	$a_1 = 10 \cdot d$
Spacing a_2 perpendicular to the CLT plane surface	$a_2 = 4 \cdot d$
Distance $a_{3,c}$ from centre of the screw-part in timber to the unloaded end	$a_{3,c} = 7 \cdot d$
Distance $a_{3,t}$ from centre of the screw-part in timber to the loaded end	$a_{3,t} = 12 \cdot d$
Distance $a_{4,c}$ from centre of the screw-part in timber to the unloaded edge	$a_{4,c} = 3 \cdot d$
Distance $a_{4,t}$ from centre of the screw-part in timber to the loaded edge	$a_{4,t} = 6 \cdot d$

For a crossed screw couple the minimum spacing between the crossing screws is $1,5 \cdot d$.

Minimum thickness for structural members is $t = 24$ mm for screws with outer thread diameter $d < 8$ mm, $t = 30$ mm for screws with outer thread diameter $d = 8$ mm, $t = 40$ mm for screws with outer thread diameter $d = 10$ mm and $t = 80$ mm for screws with outer thread diameter $d = 12$ mm.

4 Attestation and verification of constancy of performance (AVCP)

4.1 AVCP system

According to the decision 97/176/EC of the European Commission¹, as amended, the system(s) of assessment and verification of constancy of performance (see Annex V to Regulation (EU) No 305/2011) is 3.

5 Technical details necessary for the implementation of the AVCP system, as foreseen in the applicable EAD

Technical details necessary for the implementation of the AVCP system are laid down in the control plan deposited at ETA-Danmark prior to CE marking

Issued in Copenhagen on 2019-01-02 by



Thomas Bruun
Managing Director, ETA-Danmark

Annex A / 41

Screw sizes and material

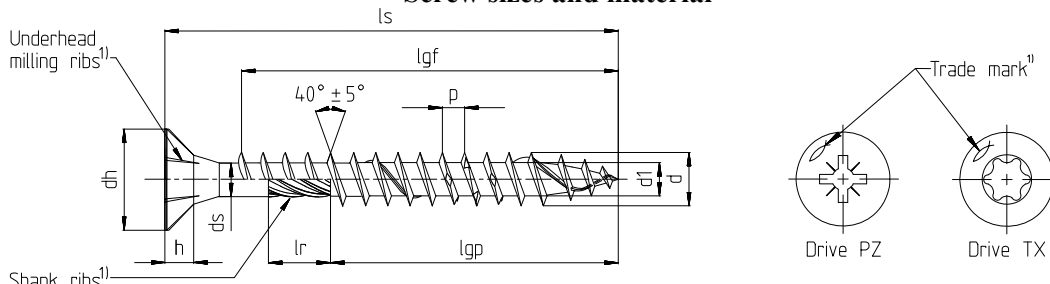

¹⁾ optional

Power-Fast self-drilling screw - Countersunk head with full- or partial thread

- Carbon Steel
- Possible surface treatments: yellow or blue zinc-plated, blue zinc-plated $\geq 12\mu\text{m}$, bonus-zincd, burnished, nickel-/ , brass plated

Nominal diameter		3,0	3,5	4,0	4,5	5,0	6,0									
d	Outer diameter	3,00	3,50	4,00	4,50	5,00	6,00									
	Allow. deviation	$\pm 0,30$														
d ₁	Core diameter	2,00	2,20	2,50	2,70	3,00	4,00									
	Allow. deviation	$-0,25 / +0,10$				$\pm 0,20$										
d _h	Head diameter	6,00	7,00	8,00	9,00	10,00	12,00									
	Allow. deviation	$-0,50 / +0,10$														
d _s	Shank diameter	2,25	2,60	2,90	3,25	3,60	4,20									
	Allow. deviation	$-0,30 / +0,10$														
h	Head height	1,90	2,10	2,50	2,70	3,00	3,80									
	Thread pitch	1,50	1,80	2,00	2,20	2,50	3,00-4,50									
p	Allow. deviation	$\pm 10\%$														
	Shank ribs length	3,75	4,25	4,75	5,50	6,00	7,00									
l _r ¹⁾	Allow. deviation	$\pm 0,75$			$\pm 1,00$											
	Drive TX	10		20		20	25	30								
Drive PZ	1	2					3									
Screw length l_s		Standard thread length l_{gf} = Full thread l_{gp} = Partial thread Tolerance: $\pm 2,0$ ²⁾														
Nominal length	min	max	l_{gf}	l_{gp}	l_{gf}	l_{gp}	l_{gf}	l_{gp}	l_{gf}	l_{gp}	l_{gf}	l_{gp}	l_{gf}	l_{gp}		
20	18,95	21,05	16		16		16		16							
25	23,75	26,25	21		21	18	20	18	20							
30	28,75	31,25	26	18	26	18	25	18	25	18	24					
35	33,50	36,50	31	24	31	24	30	24	30	24	29	24	28			
40	38,50	41,50	36	24	36	24	35	24	35	24	34	24	33	24		
45	43,50	46,50	41	30	41	30	40	30	40	30	39	30	38	30		
50	48,50	51,50			46	30	45	30	45	30	44	30	43	30		
55	53,50	56,50					50	36	50	36	49	36	48			
60	58,50	61,50						36		36		36	53	36		
70	68,50	71,50						42		42		42	63	42		
80	78,50	81,50						50		50		50	73	50		
90	88,25	91,75										60		60		
100	98,25	101,75										60		60		
110	108,25	111,75										70		70		
120	118,25	121,75										70		70		
in steps of 10mm																
130-300	$l_s - 2,00$	$l_s + 2,00$														70

All sizes in mm

- Intermediate lengths at l_s are possible
 - Screws with partial thread > 50 mm length with shank ribs
 - Threaded lengths between $4 \times d \leq l_g \leq l_{gmax}$ are possible
- ²⁾ $10\text{mm} \geq l_g \leq 18\text{mm} \triangleq \pm 1,5\text{mm}$
 $18\text{mm} \geq l_g \leq 30\text{mm} \triangleq \pm 1,7\text{mm}$

fischer Power-Fast and Construction Screws	Annex A1 of European Technical Assessment ETA-11/0027
Sizes and Material	

Appendix 15 / 41

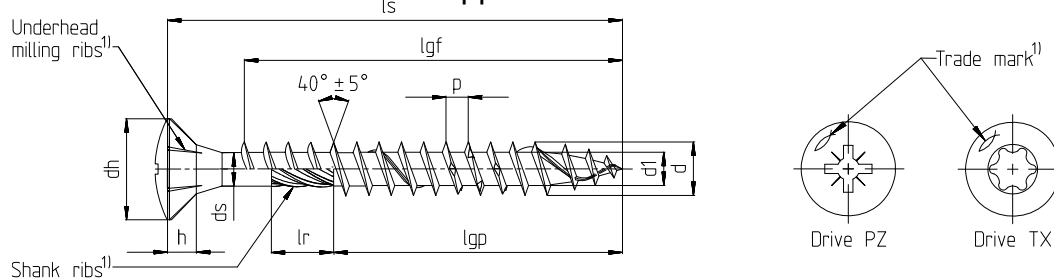

¹) optional

Power-Fast self-drilling screw - Raised countersunk head with full- or partial thread

<ul style="list-style-type: none"> Carbon steel Possible surface treatments: yellow or blue-zinc-plated, blue zinc-plated $\geq 12\mu\text{m}$, bonus-zinc-plated, burnished, nickel-/brass plated 																
Nominal diameter		3,0	3,5	4,0	4,5	5,0	6,0									
d	Outer diameter	3,00	3,50	4,00	4,50	5,00	6,00									
	Allow. deviation	$\pm 0,30$														
d ₁	Core diameter	2,00	2,20	2,50	2,70	3,00	4,00									
	Allow. deviation	$-0,25 / +0,10$					$\pm 0,20$									
d _h	Head diameter	6,00	7,00	8,00	9,00	10,00	12,00									
	Allow. deviation	$-0,50 / +0,10$														
d _s	Shank diameter	2,25	2,60	2,90	3,25	3,60	4,20									
	Allow. deviation	$-0,30 / +0,10$														
h	Head height	1,90	2,10	2,50	2,70	3,00	3,40									
p	Thread pitch	1,50	1,80	2,00	2,20	2,50	3,00-4,50									
	Allow. deviation	$\pm 10\%$														
l _r ¹⁾	Shank ribs length	3,75	4,25	4,75	5,50	6,00	7,00									
	Allow. deviation	$\pm 0,75$					$\pm 1,00$									
Drive TX		10			20			20	25	30						
Drive PZ		1	2							3						
Screw length l _s		Standard thread length l _{gf} = Full thread l _{gp} = Partial thread Tolerance: $\pm 2,0$ ²⁾														
Nominal length	min	max	l _{gf}	l _{gp}	l _{gf}	l _{gp}	l _{gf}	l _{gp}	l _{gf}	l _{gp}	l _{gf}	l _{gp}	l _{gf}	l _{gp}		
20	18,95	21,05	16		16		16		16							
25	23,75	26,25	21		21	18	20	18	20							
30	28,75	31,25	26	18	26	18	25	18	25	18	24					
35	33,50	36,50	31	24	31	24	30	24	30	24	29	24	28			
40	38,50	41,50	36	24	36	24	35	24	35	24	34	24	33	24		
45	43,50	46,50	41	30	41	30	40	30	40	30	39	30	38	30		
50	48,50	51,50			46	30	45	30	45	30	44	30	43	30		
55	53,50	56,50					50	36	50	36	49	36	48			
60	58,50	61,50						36		36		36	53	36		
70	68,50	71,50						42		42		42	63	42		
80	78,50	81,50						50		50		50	73	50		

All sizes in mm

- Intermediate lengths at l_s are possible
- Screws with partial thread > 50 mm length with shank ribs
- Threaded lengths between $4 \times d \leq l_g \leq l_{g\text{max}}$ are possible

²⁾ $10\text{mm} \geq l_g \leq 18\text{mm} \triangleq \pm 1,5\text{mm}$
 $18\text{mm} \geq l_g \leq 30\text{mm} \triangleq \pm 1,7\text{mm}$

fischer Power-Fast and Construction Screws	Annex A2 of European Technical Assessment ETA-11/0027
Sizes and Material	

Appendix 16 / 41

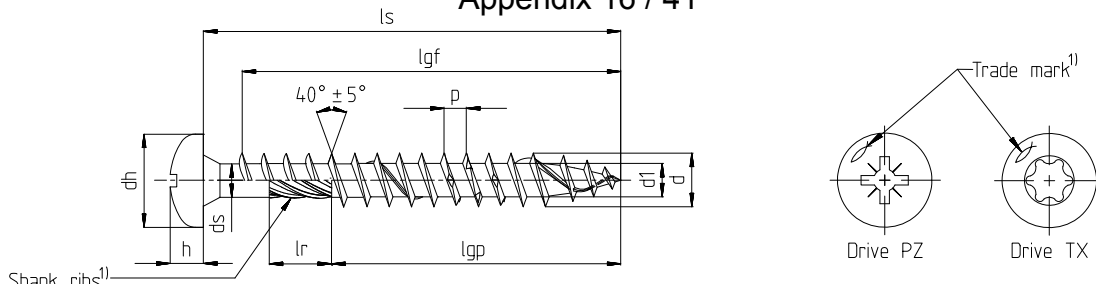

1) optional

Power-Fast self-drilling screw - Pan head with full- or partial thread

- Carbon steel
- Possible surface treatments: yellow or blue zinc-plated, blue zinc-plated $\geq 12\mu\text{m}$, bonus- zinced, burnished, nickel-/brass plated

Nominal diameter		3,0	3,5	4,0	4,5	5,0	6,0	
d	Outer diameter	3,00	3,50	4,00	4,50	5,00	6,00	
	Allow. deviation	$\pm 0,30$						
d _i	Core diameter	2,00	2,20	2,50	2,70	3,00	4,00	
	Allow. deviation	$-0,25 / +0,10$			$\pm 0,20$			
d _h	Head diameter	6,00	7,00	8,00	9,00	10,00	12,00	
	Allow. deviation	$-0,50 / +0,10$						
d _s	Shank diameter	2,25	2,60	2,90	3,25	3,60	4,20	
	Allow. deviation	$-0,30 / +0,10$						
h	Head height	2,30	2,50	2,90	3,10	3,40	3,80	
	Thread pitch	1,50	1,80	2,00	2,20	2,50	3,00-4,50	
p	Thread pitch	1,50	1,80	2,00	2,20	2,50	3,00-4,50	
	Allow. deviation	$\pm 10\%$						
l _r ¹⁾	Shank ribs length	3,75	4,25	4,75	5,50	6,00	7,00	
	Allow. deviation	$\pm 0,75$			$\pm 1,00$			
Drive TX		10		20		20	25	30
Drive PZ		1	2				3	

Screw length l _s			Standard thread length l _{gf} = Full thread l _{gp} = Partial thread Tolerance: $\pm 2,0$ ²⁾													
Nominal length	min	max	l _{gf}	l _{gp}	l _{gf}	l _{gp}	l _{gf}	l _{gp}	l _{gf}	l _{gp}	l _{gf}	l _{gp}	l _{gf}	l _{gp}		
20	18,95	21,05	16		16		16		16							
25	23,75	26,25	21		21	18	20	18	20							
30	28,75	31,25	26	18	26	18	25	18	25	18	24					
35	33,50	36,50	31	24	31	24	30	24	30	24	29	24	28			
40	38,50	41,50		24	36	24	35	24	35	24	34	24	33	24		
45	43,50	46,50		30		30	40	30	40	30	39	30	38	30		
50	48,50	51,50				30	45	30	45	30	44	36	43	30		
55	53,50	56,50					50	36	50	36	49	36	48			
60	58,50	61,50						36		36		42	53	36		
70	68,50	71,50						42		42		50	63	42		
80	78,50	81,50						50		50		50	73	50		
90	88,25	91,75										60		60		
100	98,25	101,75										60		60		

All sizes in mm

- Intermediate lengths at l_s are possible
- Screws with partial thread > 50 mm length with shank ribs
- Threaded lengths between $4 \times d \leq l_g \leq l_{gmax}$ are possible

²⁾ $10\text{mm} \geq l_g \leq 18\text{mm} \triangleq \pm 1,5\text{mm}$
 $18\text{mm} \geq l_g \leq 30\text{mm} \triangleq \pm 1,7\text{mm}$

fischer Power-Fast and Construction Screws	Annex A3 of European Technical Assessment ETA-11/0027
Sizes and Material	

Appendix 17 / 41

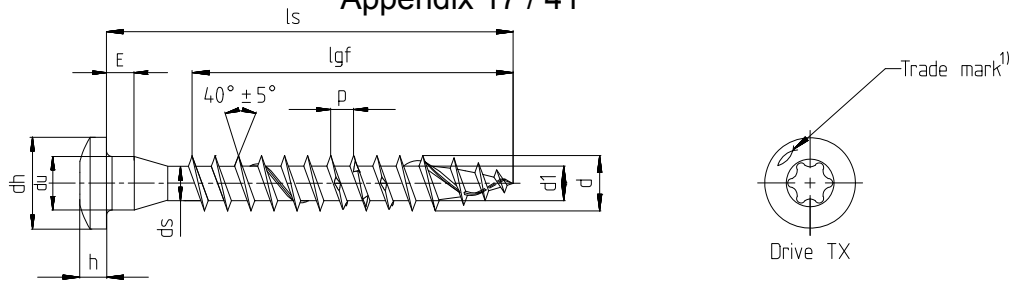

1) optional

Power-Fast self-drilling screw - Wood connector screw with full thread

Nominal diameter		5,0													
d	Outer diameter	5,00													
	Allow. deviation	-0,30													
d ₁	Core diameter	3,00													
	Allow. deviation	±0,20													
d _u	Underhead diameter	5,00													
	Allow. deviation	-0,35													
d _h	Head diameter	8,25													
	Allow. deviation	±0,40													
E	Height	2,50													
	Allow. deviation	±0,30													
h	Head height	2,60													
	Thread pitch	2,50													
p	Allow. deviation	±10%													
	Drive TX	20	25												
Screw length l _s		Standard thread length l _{gf} = Full thread l _{gp} = Partial thread Tolerance: ± 2,0 ²⁾													
Nominal length	min	max	l _{gf}	l _{gp}											
20	18,95	21,05	14												
25	23,75	26,25	19												
30	28,75	31,25	24												
35	33,50	36,50	29												
40	38,50	41,50	34												
45	43,50	46,50	39												
50	48,50	51,50	44												
55	53,50	56,50	49												
60	58,50	61,50	54												
70	68,50	71,50	64												
80	78,50	81,50	74												

All sizes in mm

- Intermediate lengths at l_s are possible
- Threaded lengths between 4×d ≤ l_g ≤ l_{gmax} are possible

- 2) 10mm ≥ l_g ≤ 18mm ± 1,5mm
18mm ≥ l_g ≤ 30mm ± 1,7mm

fischer Power-Fast and Construction Screws	Annex A4
Sizes and Material	of European Technical Assessment ETA-11/0027

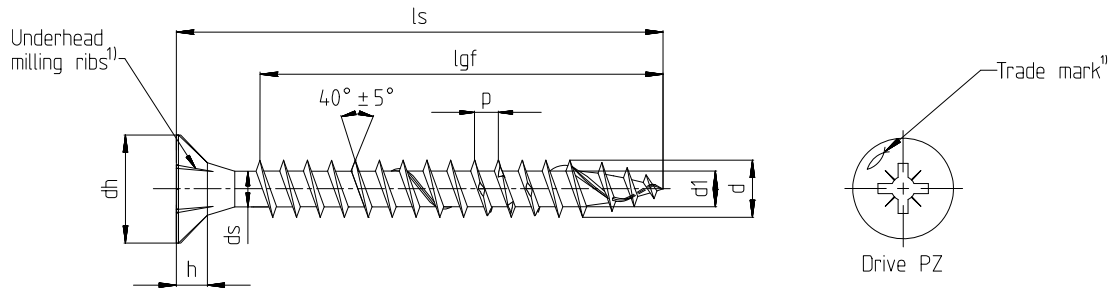

¹⁾ optional

Power-Fast self-drilling screw - Small countersunk head with full thread

<ul style="list-style-type: none"> Carbon steel Possible surface treatments: yellow or blue zinc-plated, blue zinc-plated $\geq 12\mu\text{m}$ 																
Nominal diameter		3,0	3,5	4,0												
d	Outer diameter	3,00	3,50	4,00												
	Allow. deviation	$\pm 0,30$														
d ₁	Core diameter	2,00	2,20	2,50												
	Allow. deviation	$-0,25 / +0,10$														
d _h	Head diameter	5,00	6,00	7,00												
	Allow. deviation	$-0,50 / +0,10$														
h	Head height	1,90	2,10	2,50												
p	Thread pitch	1,50	1,80	2,00												
	Allow. deviation	$\pm 10\%$														
Drive PZ		1	2													
Screw length l _s		Standard thread length l _{gf} = Full thread l _{gp} = Partial thread Tolerance: $\pm 2,0$ ²⁾														
Nominal length	min	max	l _{gf}	l _{gp}	l _{gf}	l _{gp}	l _{gf}	l _{gp}								
20	18,95	21,05	16		16		16									
25	23,75	26,25	21		21		20									
30	28,75	31,25	26													

All sizes in mm

- Intermediate lengths at l_s are possible
- Threaded lengths between $4 \times d \leq l_g \leq l_{g\text{max}}$ are possible

²⁾ $10\text{mm} \geq l_g \leq 18\text{mm} \triangleq \pm 1,5\text{mm}$
 $18\text{mm} \geq l_g \leq 30\text{mm} \triangleq \pm 1,7\text{mm}$

fischer Power-Fast and Construction Screws Sizes and Material	Annex A5 of European Technical Assessment ETA-11/0027

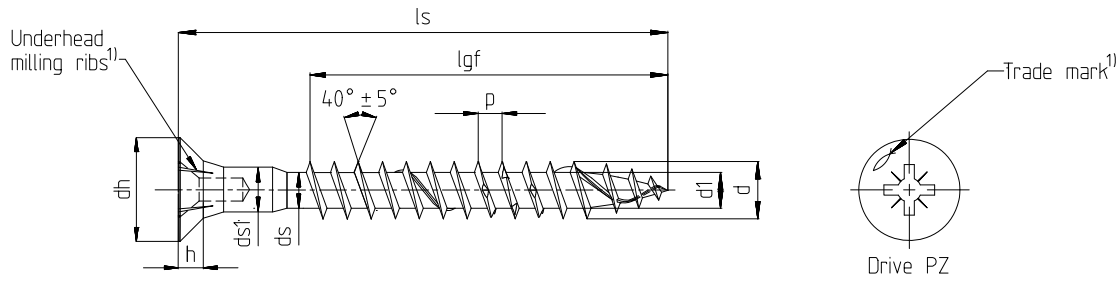

¹⁾ optional

Power-Fast self-drilling screw - Countersunk headhole screw with full thread

<ul style="list-style-type: none"> Carbon steel Possible surface treatments: blue zinc-plated, blue zinc-plated $\geq 12\mu\text{m}$ 																		
Nominal diameter		4,0	4,5	5,0	6,0													
d	Outer diameter	4,00	4,50	5,00	6,00													
	Allow. deviation	$\pm 0,30$																
d ₁	Core diameter	2,50	2,70	3,00	4,00													
	Allow. deviation	$-0,25 / +0,10$		$\pm 0,20$														
d _h	Head diameter	8,00	9,00	10,00	12,00													
	Allow. deviation	$-0,50 / +0,10$																
d _s	Shank diameter	2,90	3,25	3,60	4,30													
	Allow. deviation	$-0,30 / +0,10$																
h	Head height	2,50	2,70	3,00	3,80													
	Thread pitch	2,00	2,20	2,50	3,00-4,50													
p	Allow. deviation	$\pm 10\%$																
	Shank diameter	3,70	3,85	4,50	4,20													
d _{s1}	Allow. deviation	$-0,10$																
	Drive PZ	2			3													
Screw length l _s		Standard thread length l _{gf} = Full thread l _{gp} = Partial thread Tolerance: $\pm 2,0$ ²⁾																
Nominal length	min	max	l _{gf}	l _{gp}	l _{gf}	l _{gp}	l _{gf}	l _{gp}	l _{gf}	l _{gp}								
25	23,75	26,25	17,5															
27	25,75	28,25	19,5															
30	28,75	31,25	22,5		19													
35	33,50	36,50	27,5		24													
40	38,50	41,50	32,5		29		29											
45	43,50	46,50	37,5		34		34											
50	48,50	51,50	42,5		39		39		41									
55	53,50	56,50	47,5		44		44		46									
60	58,50	61,50	50,0		49		49		51									
70	68,50	71,50			59		60		60									
80	78,50	81,50			59		60		60									
90	88,25	91,75			59		60		60									
100	98,25	101,75					60		60									

All sizes in mm

- Intermediate lengths at l_s are possible
- Threaded lengths between $4 \times d \leq l_g \leq l_{gmax}$ are possible

²⁾ $10\text{mm} \geq l_g \leq 18\text{mm} \triangleq \pm 1,5\text{mm}$
 $18\text{mm} \geq l_g \leq 30\text{mm} \triangleq \pm 1,7\text{mm}$

fischer Power-Fast and Construction Screws	Annex A6
Sizes and Material	of European Technical Assessment ETA-11/0027

Appendix 20 / 41

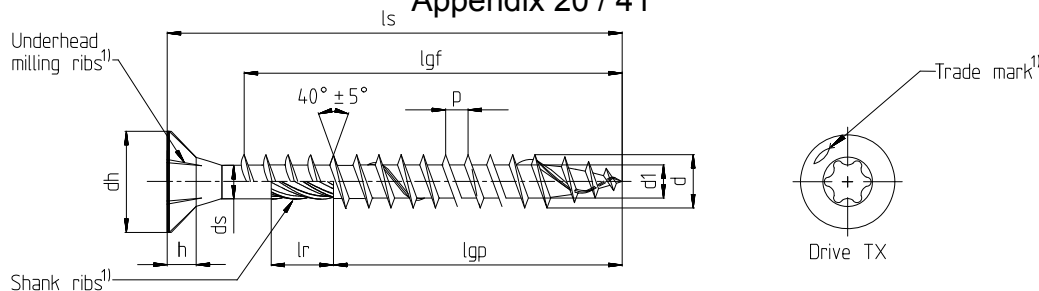

1) optional

Power-Fast wood construction screw - Countersunk head with full- or partial thread

		Nominal diameter													
		6,0	8,0	10,0	12,0										
d	Outer diameter	6,00	8,00	10,00	12,00										
	Allow. deviation	±0,30		±0,40	±0,50										
d ₁	Core diameter	4,00	5,40	6,40	7,60										
	Allow. deviation	±0,20		±0,30											
d _h	Head diameter	12,00	14,40	18,40	22,40										
	Allow. deviation	-0,50 /+0,10	±0,40		±0,50										
d _s	Shank diameter	4,30	5,90	7,10	8,30										
	Allow. deviation	-0,30 /+0,10	±0,20												
h	Head height	3,80	5,10	6,10	7,20										
	Thread pitch	3,00-4,50	6,00	7,50											
p	Allow. deviation	±10%													
	Shank ribs length	8,00	13,00												
l _r 1)	Allow. deviation	-2,00													
	Drive TX	30	40		50										
Standard thread length l _{gf} = Full thread l _{gp} =Partial thread Tolerance: ± 2,0															
Nominal length	min	max	l _{gf}	l _{gp}	l _{gf}	l _{gp}	l _{gf}	l _{gp}	l _{gf}	l _{gp}					
60	58,50	61,50	50	36											
80	78,50	81,50	70	50	70	50		52							
90	88,25	91,75		60	80	50									
100	98,25	101,75		60	80	50		52		60					
120	118,25	121,75		70	100	75		80		80					
140	138,00	142,00		70		75		80		80					
160	158,00	162,00		70		75		80		80					
180	178,00	182,00		70		75		100		100					
200	198,00	202,00		70		100		100		100					
220	218,00	222,00		70		100		100		100					
240	238,00	242,00		70		100		100		120					
260	258,00	262,00		70		100		100		120					
280	278,00	282,00		70		100		115		120					
300	298,00	302,00		70		100		115		120					
320	317,00	323,00				100		115							
330	327,00	333,00						115							
340	337,00	343,00						115							
350	347,00	353,00								145					
360	357,00	363,00						100		115					
380	377,00	383,00						100		115					
400	397,00	403,00													
450/500	l _s -3,00	l _s +3,00				100		115		145					
550/600	l _s -3,00	l _s +3,00								145					

All sizes in mm

- Intermediate lengths at l_s are possible
- Threaded lengths between 4×d ≤ l_g ≤ l_{gmax} are possible

fischer Power-Fast and Construction Screws	Annex A7 of European Technical Assessment ETA-11/0027
Sizes and Material	

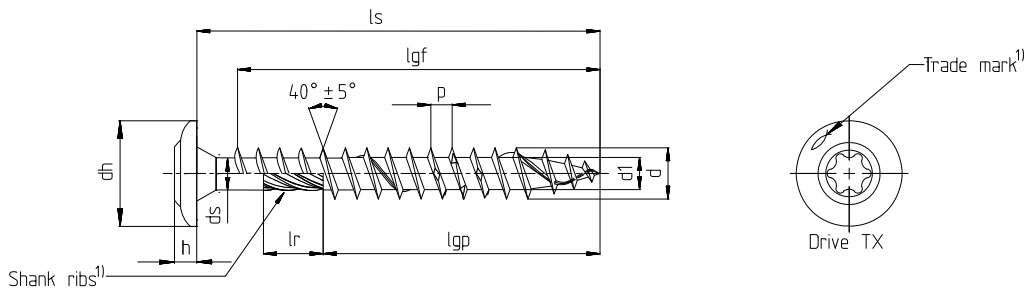

¹⁾ optional

Power-Fast wood construction screw - Flange head with full- or partial thread

<ul style="list-style-type: none"> Carbon steel Possible surface treatments: yellow or blue zinc-plated, blue zinc-plated $\geq 12\mu\text{m}$, bonus-zincd 																
Nominal diameter		6,0	8,0	10,0	12,0											
d	Outer diameter	6,00	8,00	10,00	12,00											
	Allow. deviation	$\pm 0,30$		$\pm 0,40$	$\pm 0,50$											
d ₁	Core diameter	4,00	5,40	6,40	7,60											
	Allow. deviation	$\pm 0,20$			$\pm 0,30$											
d _h	Head diameter	13,70	21,00	24,70	27,90											
	Allow. deviation	-0,70/+1,30	$\pm 1,00$	-1,20/+2,80	-1,40/+2,60											
d _s	Shank diameter	4,30	5,90	7,10	8,30											
	Allow. deviation	-0,30/+0,10	$\pm 0,20$		$\pm 0,30$											
h	Head height	3,50		5,60	6,70											
	Allow. deviation	$\pm 1,00$		$\pm 0,50$												
p	Thread pitch	3,00-4,50	6,00	7,50												
	Allow. deviation	$\pm 10\%$														
l _r ¹⁾	Shank rib length	8,00	13,00													
	Allow. deviation	$-2,00$														
Drive TX		30	40	50												
Screw length l _s		Standard thread length l _{gf} = Full thread l _{gp} =Partial thread Tolerance: $\pm 2,0$														
Nominal length	min	max	l _{gf}	l _{gp}	l _{gf}	l _{gp}	l _{gf}	l _{gp}	l _{gf}	l _{gp}						
60	58,50	61,50	50	36												
80	78,50	81,50	70	50	70	50		52								
90	88,25	91,75		60	80	50										
100	98,25	101,75		60	80	50		52		60						
120	118,25	121,75		70	100	75		80		80						
140	138,00	142,00		70		75		80		80						
160	158,00	162,00		70		75		80		80						
180	178,00	182,00		70		75		100		100						
200	198,00	202,00		70		100				100						
220	218,00	222,00		70		100		100		100						
240	238,00	242,00		70		100		100		100						
260	258,00	262,00		70		100		100		100						
280	278,00	282,00		70		100		115		120						
300	298,00	302,00		70		100		115		120						
320	317,00	323,00				100		115								
330	327,00	333,00						115								
340	337,00	343,00				100		115								
350	347,00	353,00								145						
in steps of 10mm																
360-500	l _s -3,00	l _s +3,00				100		115								
in steps of 50mm																
550-600	l _s -3,00	l _s +3,00								145						

All sizes in mm

- Intermediate lengths at l_s are possible
- Threaded lengths between $4 \times d \leq l_g \leq l_{gmax}$ are possible

fischer Power-Fast and Construction Screws	Annex A8 of European Technical Assessment ETA-11/0027
Sizes and Material	

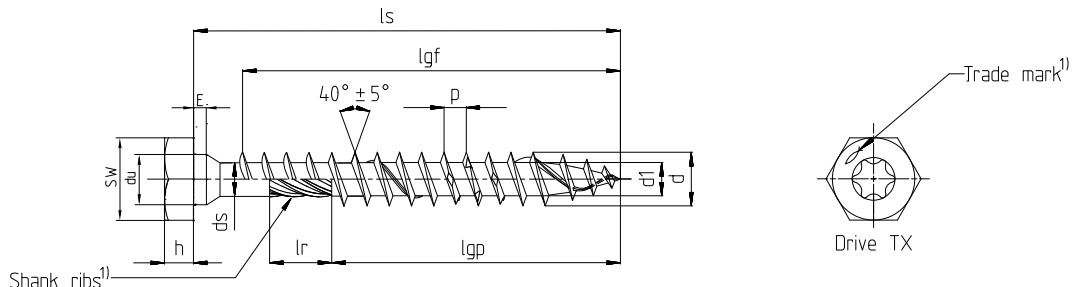

1) optional

Power-Fast wood construction screw - Hexagon head with full- or partial thread

<ul style="list-style-type: none"> Carbon steel Possible surface treatments: yellow or blue zinc-plated, blue zinc-plated $\geq 12\mu\text{m}$, bonus-zincd 																		
Nominal diameter		6,0	8,0	10,0	12,0													
d	Outer diameter	6,00	8,00	10,00	12,00													
	Allow. deviation	$\pm 0,30$		$\pm 0,40$	$\pm 0,50$													
d _i	Core diameter	4,00	5,40	6,40	7,60													
	Allow. deviation	$\pm 0,20$			$\pm 0,30$													
d _u	Underhead diameter	6,25	8,25	10,30	12,40													
	Allow. deviation	-0,80		-0,90	-1,00													
SW	Wrench size	9,90	12,80	14,80	16,80													
	Allow. deviation	$\pm 0,30$																
E	Height	2,00	2,10	2,30	3,30													
	Allow. deviation	$\pm 0,50$																
d _s	Shank diameter	4,30	5,90	7,10	8,30													
	Allow. deviation	-0,30/+0,10		$\pm 0,20$														
h	Head height	4,00	4,50	5,20	5,70													
	Allow. deviation	$\pm 0,30$	$\pm 0,40$	$\pm 0,50$														
p	Thread pitch	3,00-4,50	6,00	7,50														
	Allow. deviation	$\pm 10\%$																
l _r ¹⁾	Shank rib length	8,00		13,00														
	Allow. deviation	-2,00																
Drive TX		30	40	50														
Screw length l _s			Standard thread length l _{gf} = Full thread l _{gp} =Partial thread Tolerance: $\pm 2,0^2)$															
Nominal length	min	max	l _{gf}	l _{gp}	l _{gf}	l _{gp}	l _{gf}	l _{gp}	l _{gf}	l _{gp}								
60	58,5	61,5	50	30														
80	78,5	81,5	70	50	70	50		52										
90	88,25	91,75		60	80	50												
100	98,25	101,75		60	80	50		52		60								
120	118,25	121,75		70	100	75		80		80								
140/160	l _s -2,00	l _s +2,00		70		75		80		80								
180	178,00	182,00		70		75		100		100								
200/220	l _s -2,00	l _s +2,00		70		100		100		100								
240/260	l _s -2,00	l _s +2,00		70		100		100		120								
280/300	l _s -2,00	l _s +2,00		70		100		115		120								
320	317,00	323,00				100		115										
330	327,00	333,00						115										
340	337,00	343,00					100	115										
350	347,00	353,00								145								
360/380	l _s -3,00	l _s +3,00				100		115										
in steps of 50mm																		
400-500	l _s -3,00	l _s +3,00				100		115		145								
550/600	l _s -3,00	l _s +3,00								145								

All sizes in mm

- Intermediate lengths at l_s are possible
- Threaded lengths between $4 \times d \leq l_g \leq l_{gmax}$ are possible

²⁾ $18\text{mm} \geq l_g \leq 30\text{mm} \triangleq \pm 1,7\text{mm}$

fischer Power-Fast and Construction Screws	Annex A9 of European Technical Assessment ETA-11/0027
Sizes and Material	

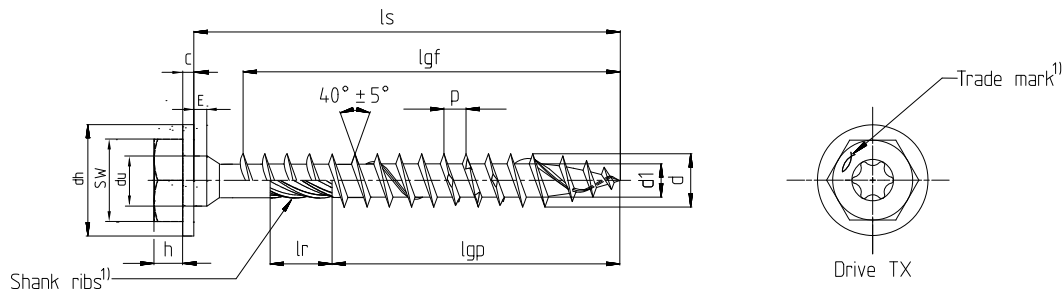

¹⁾ optional

Power-Fast wood construction screw - Hexagon head with washer and full- or partial thread

<ul style="list-style-type: none"> Carbon steel Possible surface treatments: yellow or blue zinc-plated, blue zinc-plated $\geq 12\mu\text{m}$, bonus-zinc 										
Nominal diameter		6,0	8,0	10,0	12,0					
d	Outer diameter	6,00	8,00	10,00	12,00					
	Allow. deviation	$\pm 0,30$		$\pm 0,40$	$\pm 0,50$					
d _i	Core diameter	4,00	5,40	6,40	7,60					
	Allow. deviation	$\pm 0,20$		$\pm 0,30$						
d _h	Head diameter	15,00	18,00	21,50	23,40					
	Allow. deviation	1,20		1,50						
d _u	Underhead diameter	6,25	8,25	10,30	12,40					
	Allow. deviation	-0,80		-0,90	-1,00					
SW	Wrench size	9,90	12,80	14,80	16,80					
	Allow. deviation	$\pm 0,30$								
c	Washer height	1,80	2,00	2,20	2,50					
	Height	2,00	2,10	2,30	3,30					
E	Allow. deviation	$\pm 0,50$								
	Shank diameter	4,30	5,90	7,10	8,30					
d _s	Allow. deviation	-0,30/+0,10		$\pm 0,20$						
	Head height	4,00	4,50	5,20	5,70					
h	Allow. deviation	$\pm 0,30$	$\pm 0,40$	$\pm 0,50$						
	Thread pitch	3,00-4,50	6,00	7,50						
p	Allow. deviation	$\pm 10\%$								
	l _r ¹⁾	Shank rib length	8,00		13,00					
Allow. deviation		-2,00								
Drive TX		30	40		50					
Screw length l _s		Standard thread length l _{gf} = Full thread l _{gp} = Partial thread Tolerance: $\pm 2,0$ ²⁾								
Nominal length	min	max	l _{gf}	l _{gp}	l _{gf}	l _{gp}	l _{gf}	l _{gp}	l _{gf}	l _{gp}
60	58,50	61,50	50	30						
80	78,50	81,50	70	50	70	50		52		
90	88,25	91,75		60	80	50				
100	98,25	101,75		60	80	50		52	60	
120	118,25	121,75		70	100	75		80	80	
140/160	l _s -2,00	l _s +2,00		70		75		80	80	
180	178,00	182,00		70		75		100	100	
200/220	l _s -2,00	l _s +2,00		70		100		100	100	
240/260	l _s -2,00	l _s +2,00		70		100		100	120	
280/300	l _s -2,00	l _s +2,00		70		100		115	120	
320	317,00	323,00				100		115		
330	327,00	333,00						115		
340	337,00	343,00				100		115		
350	347,00	353,00							145	
360/380	l _s -3,00	l _s +3,00				100		115		
in steps of 50mm										
400-500	l _s -3,00	l _s +3,00				100		115	145	
550/600	l _s -3,00	l _s +3,00							145	

All sizes in mm

- Intermediate lengths at l_s are possible
- Threaded lengths between $4 \times d \leq l_g \leq l_{gmax}$ are possible

²⁾ $18\text{mm} \geq l_g \leq 30\text{mm} \triangleq \pm 1,7\text{mm}$

fischer Power-Fast and Construction Screws Sizes and Material	Annex A10 of European Technical Assessment ETA-11/0027

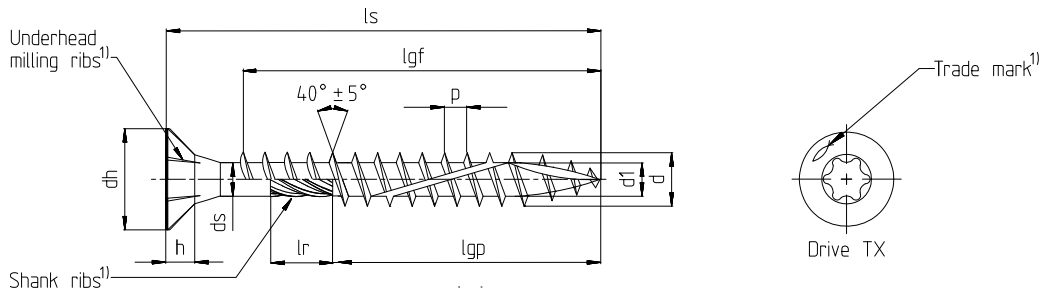

¹⁾ optional

FCS wood construction screw - Countersunk head with full- or partial thread

<ul style="list-style-type: none"> Carbon steel Possible surface treatments: yellow or blue zinc-plated, blue zinc-plated $\geq 12\mu\text{m}$, bonus-zincd 															
Nominal diameter		8,0	10,0												
d	Outer diameter	8,00	10,00												
	Allow. deviation	$\pm 0,30$	$\pm 0,40$												
d ₁	Core diameter	5,40	6,35												
	Allow. deviation	$-0,30/+0,20$													
d _h	Head diameter	14,40	18,40												
	Allow. deviation	$\pm 0,40$													
d _s	Shank diameter	5,90	7,10												
	Allow. deviation	$-0,30/+0,10$													
h	Head height	6,00-7,00	7,50-8,50												
p	Thread pitch	5,20	5,60												
	Allow. deviation	$\pm 10\%$													
l _r ¹⁾	Shank rib length	13,0													
	Allow. deviation	$-2,00$													
Drive TX		40													
Screw length l _s		Standard thread length l _{gf} = Full thread l _{gp} =Partial thread Tolerance: $\pm 2,0$													
Nominal length	min	max	l _{gf}	l _{gp}	l _{gf}	l _{gp}									
80	78,50	81,50	70	50		52									
90	88,25	91,75	80	50		52									
100	98,25	101,75	80	50		52									
110	108,25	111,75	100	75		80									
120	118,25	121,75		75		80									
in steps of 10mm															
130-400	l _s -2,00	l _s +2,00		75		80									

All sizes in mm

- Intermediate lengths at l_s are possible
- Threaded lengths between $4 \times d \leq l_g \leq l_{gmax}$ are possible

Appendix 25 / 41

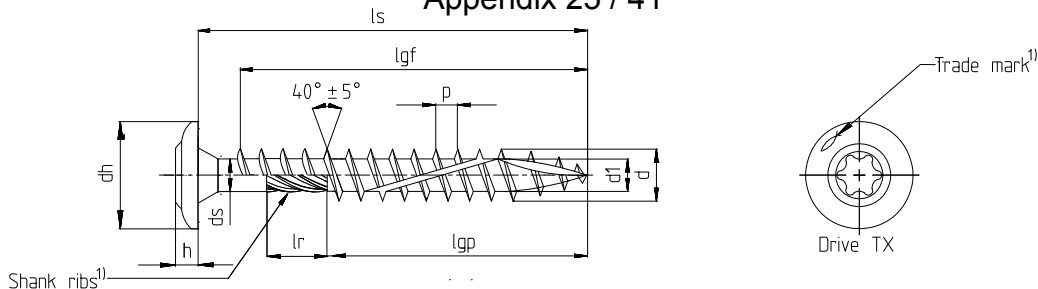

1) optional

FCS wood construction screw - Flange head with partial thread

- Carbon steel
- Possible surface treatments: yellow or blue zinc-plated, blue zinc-plated $\geq 12\mu\text{m}$

Nominal diameter		8,0	10,0												
d	Outer diameter	8,00	10,00												
	Allow. deviation	-0,40/+0,30	$\pm 0,40$												
d ₁	Core diameter	5,40	6,35												
	Allow. deviation	$\pm 0,30$													
d _h	Head diameter	21,00	24,70												
	Allow. deviation	$\pm 1,00$	-1,20/+2,80												
d _s	Shank diameter	5,90	7,10												
	Allow. deviation	-0,30/+0,20													
h	Head height	2,50-4,50	3,70-5,70												
	Thread pitch	5,20	5,60												
p	Allow. deviation	$\pm 10\%$													
	Shank rib length	12,00													
l _r ¹⁾	Allow. deviation	$\pm 1,00$													
	Drive TX	40													
Screw length l _s		Standard thread length l _{gf} = Full thread l _{gp} = Partial thread Tolerance: $\pm 2,0$													
Nominal length	min	max	l _{gf}	l _{gp}	l _{gf}	l _{gp}									
80	78,50	81,50	70	50		52									
90	88,25	91,75	80	50		52									
100	98,25	101,75	80	50		52									
110	108,25	111,75	100	75		80									
120	118,25	121,75		75		80									
in steps pf 10mm															
130-400	l _s -2,00	l _s +2,00		75		80									

All sizes in mm

- Intermediate lengths at l_s are possible
- Threaded lengths between $4 \times d \leq l_g \leq l_{g\text{max}}$ are possible

fischer Power-Fast and Construction Screws	Annex A12
Sizes and Material	of European Technical Assessment ETA-11/0027

Appendix 26 / 41

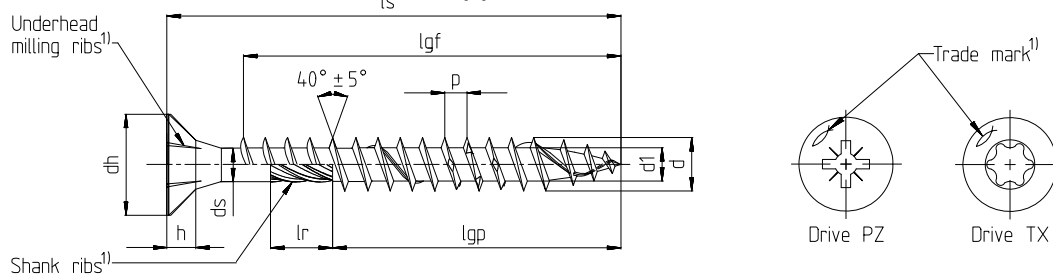

1) optional

Power-Fast self-drilling screw - Countersunk head with full- or partial thread

▪ Stainless steel																
Nominal diameter		3,0	3,5	4,0	4,5	5,0	6,0									
d	Outer diameter	3,00	3,50	4,00	4,50	5,00	6,00									
	Allow. deviation	±0,30														
d ₁	Core diameter	2,00	2,20	2,50	2,70	3,00	4,00									
	Allow. deviation	-0,25 / +0,10					±0,20									
d _h	Head diameter	6,00	7,00	8,00	9,00	10,00	12,00									
	Allow. deviation	-0,50 / +0,10														
d _s	Shank diameter	2,25	2,60	2,90	3,25	3,60	4,30									
	Allow. deviation	-0,30 / +0,10														
h	Head height	1,90	2,10	2,50	2,70	3,00	3,80									
	Thread pitch	1,50	1,80	2,00	2,20	2,50	3,00-4,50									
p	Allow. deviation	±10%														
	Shank rib length	3,75	4,25	4,75	5,50	6,00	7,00									
l _r ¹⁾	Allow. deviation	±0,75					±1,00									
	Drive TX	10			20			20	25	30						
Drive PZ	1	2								3						
Screw length l _s		Standard thread length l _{gf} = Full- thread l _{gp} = Partial thread Tolerance: ± 2,0 ²⁾														
Nominal length	min	max	l _{gf}	l _{gp}	l _{gf}	l _{gp}	l _{gf}	l _{gp}	l _{gf}	l _{gp}	l _{gf}	l _{gp}	l _{gf}	l _{gp}		
20	18,95	21,05	16		16		16		16							
25	23,75	26,25	21		21	18	20	18	20							
30	28,75	31,25	26	18	26	18	25	18	25	18	24					
35	33,50	36,50	31	24	31	24	30	24	30	24	29	24	28			
40	38,50	41,50	36	24	36	24	35	24	35	24	34	24	33	24		
45	43,50	46,50	41	30	41	30	40	30	40	30	39	30	38	30		
50	48,50	51,50			46	30	45	30	45	30	44	30	43	30		
55	53,50	56,50					50	36	50	36	49	36	48			
60	58,50	61,50						36		36		36	53	36		
70	68,50	71,50						42		42		42	63	42		
80	78,50	81,50						50		50		50	73	50		
90	88,25	91,75										60		60		
100	98,25	101,75										60		60		
110	108,25	111,75										70		70		
120	118,25	121,75										70		70		
in steps of 10mm																
130-300	l _s -2,00	l _s +2,00													70	

All sizes in mm

- Intermediate lengths at l_s are possible
- Screws with partial thread > 50 mm length with shank ribs
- Threaded lengths between 4×d ≤ l_g ≤ l_{gmax} are possible

2) 10mm ≥ l_g ≤ 18mm ≅ ±1,5mm
18mm ≥ l_g ≤ 30mm ≅ ±1,7mm

fischer Power-Fast and Construction Screws	Annex A13
Sizes and Material	of European Technical Assessment ETA-11/0027

Appendix 27 / 41

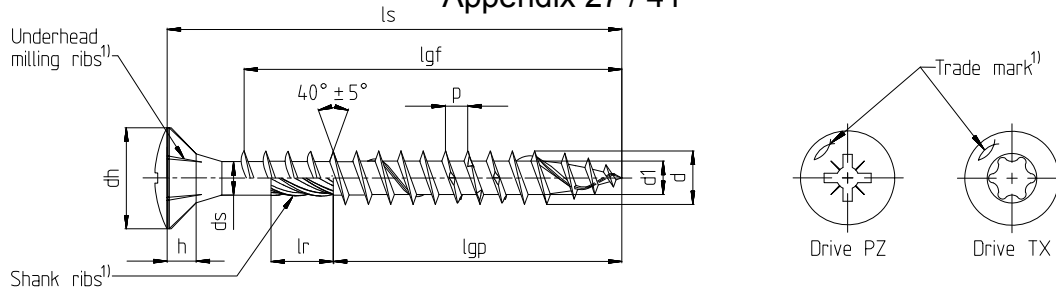

1) optional

Power-Fast self-drilling screw - Raised countersunk head with full- or partial thread

Nominal diameter		3,0	3,5	4,0	4,5	5,0	6,0									
d	Outer diameter	3,00	3,50	4,00	4,50	5,00	6,00									
	Allow. deviation	±0,30														
d ₁	Core diameter	2,00	2,20	2,50	2,70	3,00	4,00									
	Allow. deviation	-0,25 / +0,10				±0,20										
d _h	Head diameter	6,00	7,00	8,00	9,00	10,00	12,00									
	Allow. deviation	-0,50 / +0,10														
d _s	Shank diameter	2,25	2,60	2,90	3,25	3,60	4,30									
	Allow. deviation	-0,30 / +0,10														
h	Head height	1,90	2,10	2,50	2,70	3,00	3,80									
	Allow. deviation	±10%														
p	Thread pitch	1,50	1,80	2,00	2,20	2,50	3,00-4,50									
	Allow. deviation	±10%														
l _r ¹⁾	Shank ribs length	3,75	4,25	4,75	5,50	6,00	7,00									
	Allow. deviation	±0,75			±1,00											
Drive TX		10		20		20	25	30								
Drive PZ		1	2				3									
Screw length l _s		Standard thread length l _{gf} = Full thread l _{gp} = Partial thread Tolerance: ± 2,0 ²⁾														
Nominal length	min	max	l _{gf}	l _{gp}	l _{gf}	l _{gp}	l _{gf}	l _{gp}	l _{gf}	l _{gp}	l _{gf}	l _{gp}	l _{gf}	l _{gp}		
20	18,95	21,05	16		16		16		16							
25	23,75	26,25	21		21	18	21	18	20							
30	28,75	31,25	26	18	26	18	26	18	25	18	24					
35	33,50	36,50	31	24	31	24	31	24	30	24	29	24	28			
40	38,50	41,50		24	36	24	36	24	35	24	34	24	33			
45	43,50	46,50		30		30	41	30	40	30	39	30	38			
50	48,50	51,50				30	46	30	45	30	44	30	43			
55	53,50	56,50						36		36		36				
60	58,50	61,50						36		36		36	53			
70	68,50	71,50						42		42		42	63			
80	78,50	81,50						50		50		50	73			

All sizes in mm

- Intermediate lengths at l_s are possible
- Screws with partial thread > 50 mm length with shank ribs
- Threaded lengths between 4×d ≤ l_g ≤ l_{gmax} are possible

²⁾ 10mm ≥ l_g ≤ 18mm ≅ ±1,5mm
18mm ≥ l_g ≤ 30mm ≅ ±1,7mm

fischer Power-Fast and Construction Screws	Annex A14 of European Technical Assessment ETA-11/0027
Sizes and Material	

Appendix 28 / 41

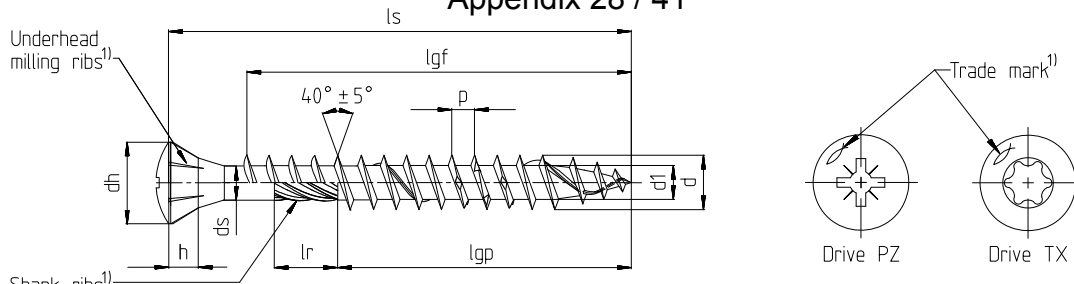

1) optional

Power-Fast self-drilling screw – Facade screw with full- or partial thread

Stainless steel																
Nominal diameter		4,0	4,5	5,0												
d	Outer diameter	4,00	4,50	5,00												
	Allow. deviation	±0,30														
d _i	Core diameter	2,50	2,70	3,00												
	Allow. deviation	-0,25 / +0,10		±0,20												
d _h	Head diameter	6,90	6,90	7,80												
	Allow. deviation	±0,50														
d _s	Shank diameter	2,90	3,25	3,60												
	Allow. deviation	-0,30 / +0,10														
h	Head height	2,50	2,70	3,00												
	Thread pitch	2,00	2,20	2,50												
p	Thread pitch	2,00	2,20	2,50												
	Allow. deviation	±10%														
l _r ¹⁾	Shank ribs length	4,75	5,50	6,00												
	Allow. deviation	±0,75	±1,00													
Drive TX		20		20	25											
Drive PZ		2														
Screw length l _s			Standard thread length l _{gf} = Full thread l _{gp} = Partial thread Tolerance: ± 2,0 ²⁾													
Nominal length	min	max	l _{gf}	l _{gp}	l _{gf}	l _{gp}	l _{gf}	l _{gp}								
20	18,95	21,05	16		16											
25	23,75	26,25	21	18	20											
30	28,75	31,25	26	18	25	18	24									
35	33,50	36,50	31	24	30	24	29	24								
40	38,50	41,50	36	24	35	24	34	24								
45	43,50	46,50	41	30	40	30	39	30								
50	48,50	51,50	46	30	45	30	44	30								
55	53,50	56,50		36		36		36								
60	58,50	61,50		36		36		36								
70	68,50	71,50		42		42		42								
80	78,50	81,50		50		50		50								
90	88,25	91,75						60								
100	98,25	101,75						60								
110	108,25	111,75						70								
120	118,25	121,75						70								

All sizes in mm

- Intermediate lengths at l_s are possible
- Screws with partial thread > 50 mm length with shank ribs
- Threaded lengths between 4×d ≤ l_g ≤ l_{gmax} are possible

²⁾ 10mm ≥ l_g ≤ 18mm ≅ ±1,5mm
18mm ≥ l_g ≤ 30mm ≅ ±1,7mm

fischer Power-Fast and Construction Screws	Annex A15
Sizes and Material	of European Technical Assessment ETA-11/0027

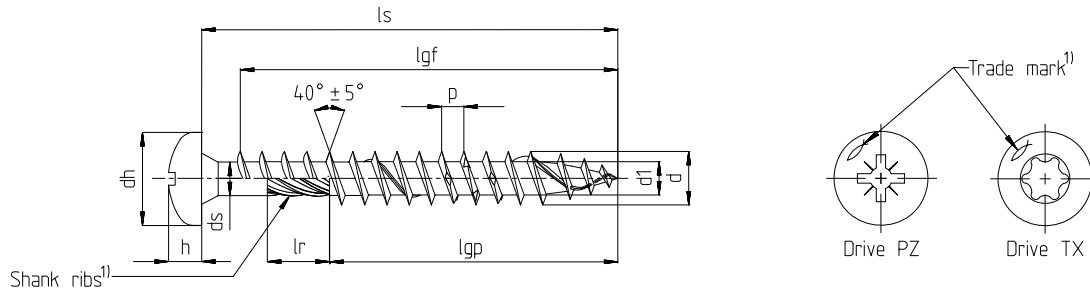

¹⁾ optional

Power-Fast self-drilling screw - Pan head with full- or partial thread

Stainless steel																
Nominal diameter		3,0	3,5	4,0	4,5	5,0	6,0									
d	Outer diameter	3,00	3,50	4,00	4,50	5,00	6,00									
	Allow. deviation	±0,30														
d _i	Core diameter	2,00	2,20	2,50	2,70	3,00	4,00									
	Allow. deviation	-0,25 / +0,10					±0,20									
d _h	Head diameter	6,00	7,00	8,00	9,00	10,00	12,00									
	Allow. deviation	-0,50 / +0,10														
d _s	Shank diameter	2,25	2,60	2,90	3,25	3,60	4,30									
	Allow. deviation	-0,30 / +0,10														
h	Head height	2,30	2,50	2,90	3,10	3,40	3,80									
p	Thread pitch	1,50	1,80	2,00	2,20	2,50	3,00-4,50									
	Allow. deviation	±10%														
l _r ¹⁾	Shank ribs length	3,75	4,25	4,75	5,50	6,00	7,00									
	Allow. deviation	±0,75					±1,00									
Drive TX		10			20			20	25	30						
Drive PZ		1	2				3									
Screw length l _s		Standard thread length l _{gf} = Full thread l _{gp} =Partial thread Tolerance: ± 2,0 ²⁾														
Nominal length	min	max	l _{gf}	l _{gp}	l _{gf}	l _{gp}	l _{gf}	l _{gp}	l _{gf}	l _{gp}	l _{gf}	l _{gp}	l _{gf}	l _{gp}		
20	18,95	21,05	16		16		16									
25	23,75	26,25	21		21	18	20	18	20							
30	28,75	31,25	26	18	26	18	25	18	25	18	24					
35	33,50	36,50	31	24	31	24	30	24	30	24	29	24	28			
40	38,50	41,50		24	36	24	35	24	35	24	34	24	33	24		
45	43,50	46,50		30		30	40	30	40	30	39	30	38	30		
50	48,50	51,50				30	45	30	45	30	44	36	43	30		
55	53,50	56,50					50	36	50	36	49	36	48			
60	58,50	61,50						36		36		42	53	36		
70	68,50	71,50						42		42		50	63	42		
80	78,50	81,50						50		50		50	73	50		
90	88,25	91,75										60		60		
100	98,25	101,75										60		60		

All sizes in mm

- Intermediate lengths at l_s are possible
- Screws with partial thread > 50 mm length with shank ribs
- Threaded lengths between 4×d ≤ l_g ≤ l_{gmax} are possible

²⁾ 10mm ≥ l_g ≤ 18mm ≅ ±1,5mm
 18mm ≥ l_g ≤ 30mm ≅ ±1,7mm

fischer Power-Fast and Construction Screws	Annex A16 of European Technical Assessment ETA-11/0027
Sizes and Material	

Appendix 30 / 41

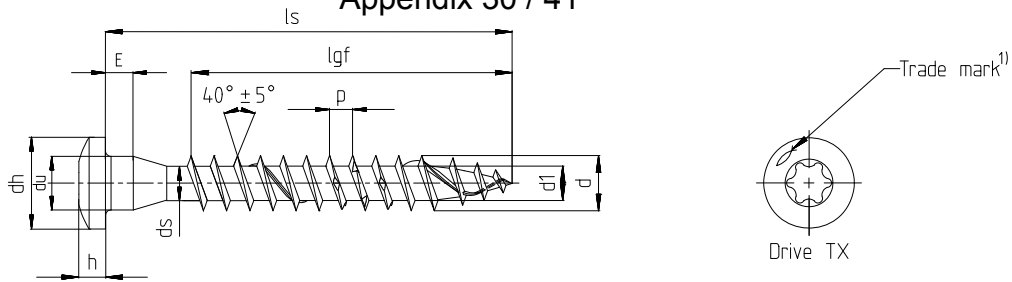

1) optional

Power-Fast self-drilling screw - Wood connector screw with full thread

Nominal diameter		5,0													
d	Outer diameter	5,00													
	Allow. deviation	-0,30													
d _l	Core diameter	3,00													
	Allow. deviation	±0,20													
d _u	Underhead diameter	5,00													
	Allow. deviation	-0,35													
d _h	Head diameter	8,25													
	Allow. deviation	±0,40													
E	Height	2,50													
	Allow. deviation	±0,30													
h	Head height	2,60													
p	Thread pitch	2,50													
	Allow. deviation	±10%													
Drive TX		20	25												
Screw length l _s				Standard thread length l _{gf} = Full thread l _{gp} = Partial thread Tolerance: ± 2,0 ²⁾											
Nominal length	min	max	l _{gf}	l _{gp}											
20	18,95	21,05	14												
25	23,75	26,25	19												
30	28,75	31,25	24												
35	33,50	36,50	29												
40	38,50	41,50	34												
45	43,50	46,50	39												
50	48,50	51,50	44												
55	53,50	56,50	49												
60	58,50	61,50	54												
70	68,50	71,50	64												
80	78,50	81,50	74												

All sizes in mm

- Intermediate lengths at l_s are possible
- Threaded lengths between 4×d ≤ l_g ≤ l_{gmax} are possible

2) 10mm ≥ l_g ≤ 18mm ≙ ±1,5mm
18mm ≥ l_g ≤ 30mm ≙ ±1,7mm

fischer Power-Fast and Construction Screws	Annex A17
Sizes and Material	of European Technical Assessment ETA-11/0027

Appendix 31 / 41

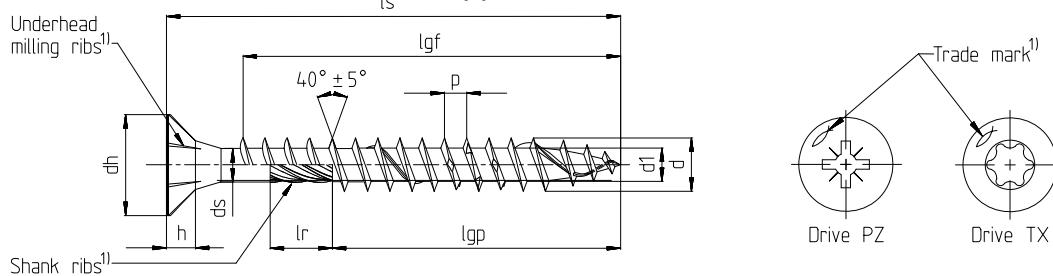

1) optional

Power-Fast wood construction screw - Countersunk head with full- or partial thread

Nominal diameter		6,0	8,0												
d	Outer diameter	6,00	8,00												
	Allow. deviation	±0,30													
d ₁	Core diameter	4,00	5,40												
	Allow. deviation	±0,20													
d _h	Head diameter	12,00	14,40												
	Allow. deviation	-0,50/+0,10	±0,40												
d _s	Shank diameter	4,30	5,90												
	Allow. deviation	-0,30/+0,10	±0,20												
h	Head height	3,80	5,10												
	Thread pitch	3,00-4,50	6,00												
p	Allow. deviation	±10%													
	Shank rib length	7,00	13,00												
l _r ¹⁾	Allow. deviation	±1,00	-2,00												
	Drive TX	30	40												
	Drive PZ	3	-												
Screw length l _s		Standard thread length l _{gf} = Full thread l _{gp} = Partial thread Tolerance: ± 2,0													
Nominal length	min	max	l _{gf}	l _{gp}	l _{gf}	l _{gp}									
60	58,50	61,50	50	36											
80	78,50	81,50	70	50	70	50									
90	88,25	91,75		60	80	50									
100	98,25	101,75		60	80	50									
120	118,25	121,75		70	100	75									
140	138,00	142,00		70		75									
160	158,00	162,00		70		75									
180	178,00	182,00		70		75									
in steps of 20mm															
200-300	l _s -2,00	l _s +2,00		70		100									
in steps of 20mm															
320-500	l _s -3,00	l _s +3,00				100									

All sizes in mm

- Intermediate lengths at l_s are possible
- Screws with partial thread > 50 mm length with shank ribs
- Threaded lengths between 4×d ≤ l_g ≤ l_{gmax} are possible

fischer Power-Fast and Construction Screws	Annex A18
Sizes and Material	of European Technical Assessment ETA-11/0027

Appendix 32 / 41

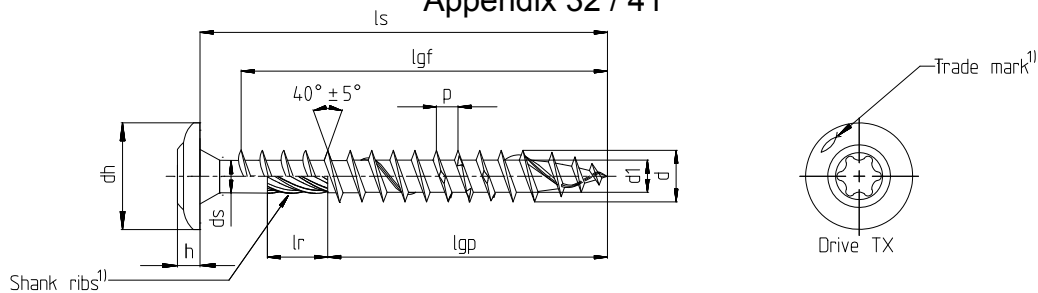

1) optional

Power-Fast wood construction screw - Flange head with full- or partial thread

Stainless steel												
Nominal diameter		6,0	8,0									
d	Outer diameter	6,00	8,00									
	Allow. deviation	±0,30										
d ₁	Core diameter	4,00	5,40									
	Allow. deviation	-0,30/+0,20										
d _h	Head diameter	13,70	21,00									
	Allow. deviation	-0,70/+1,30	±1,00									
d _s	Shank diameter	4,30	5,90									
	Allow. deviation	-0,30/+0,10										
h	Head height	3,50										
	Allow. deviation	±1,00										
p	Thread pitch	3,00-4,50	6,00									
	Allow. deviation	±10%										
l _r ¹⁾	Shank rib length	8,00	13,00									
	Allow. deviation	-2,00										
Drive TX		30	40									
Screw length l _s				Standard thread length l _{gf} = Full thread l _{gp} = Partial thread Tolerance: ± 2,0								
Nominal length	min	max	l _{gf}	l _{gp}	l _{gf}	l _{gp}						
60	58,50	61,50	50	36								
80	78,50	81,50	70	50	70	50						
90	88,25	91,75		60	80	50						
100	98,25	101,75		60	80	50						
120	118,25	121,75		70	100	75						
140	138,00	142,00		70		75						
160	158,00	162,00		70		75						
180	178,00	182,00		70		75						
in steps of 20mm												
200-300	l _s - 2,00	l _s + 2,00		70		100						
in steps of 20mm												
320-500	l _s - 3,00	l _s + 3,00				100						

All sizes in mm

- Intermediate lengths at l_s are possible
- Threaded lengths between 4×d ≤ l_g ≤ l_{gmax} are possible

fischer Power-Fast and Construction Screws	Annex A19
Sizes and Material	of European Technical Assessment ETA-11/0027

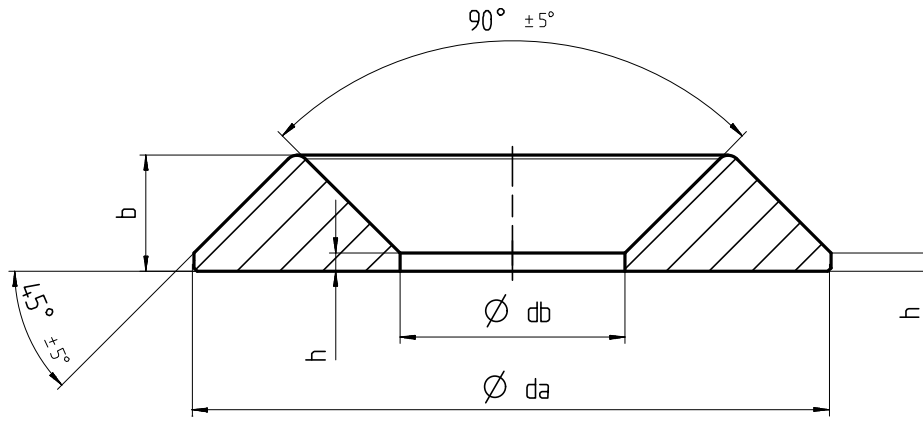

Washer for Power-Fast and construction screws

<ul style="list-style-type: none"> ▪ Carbon Steel - possible surface treatments: yellow or blue zinc-plated, bonus- zined, $\geq 12\mu\text{m}$ blue zinc-plated ▪ Stainless steel 								
Nominal diameter		Type 1				Type 2		
Size		6	8	10	12	6	8	10
db	Inner diameter	6,70	8,70	11,20	6,70	6,70	8,70	11,20
	Allow. deviation	-0,40						
da	Outer diameter	21	30	35	43	21	25,50	30,50
	Allow. deviation	$\pm 2,0$						
b	Height	4,70	5,20	6,20	8,30	4,70	5,20	6,20
	Allow. deviation	-0,40						
h	Height	1,50	1,80	2,00	2,20	1,50	1,80	2,00
	Allow. deviation	-0,15						

All sizes in mm

fischer Power-Fast and Construction Screws	Annex A20 of European Technical Assessment ETA-11/0027
Accessories	

Appendix 34 / 41
Annex B1
Fixing of on-roof insulation system

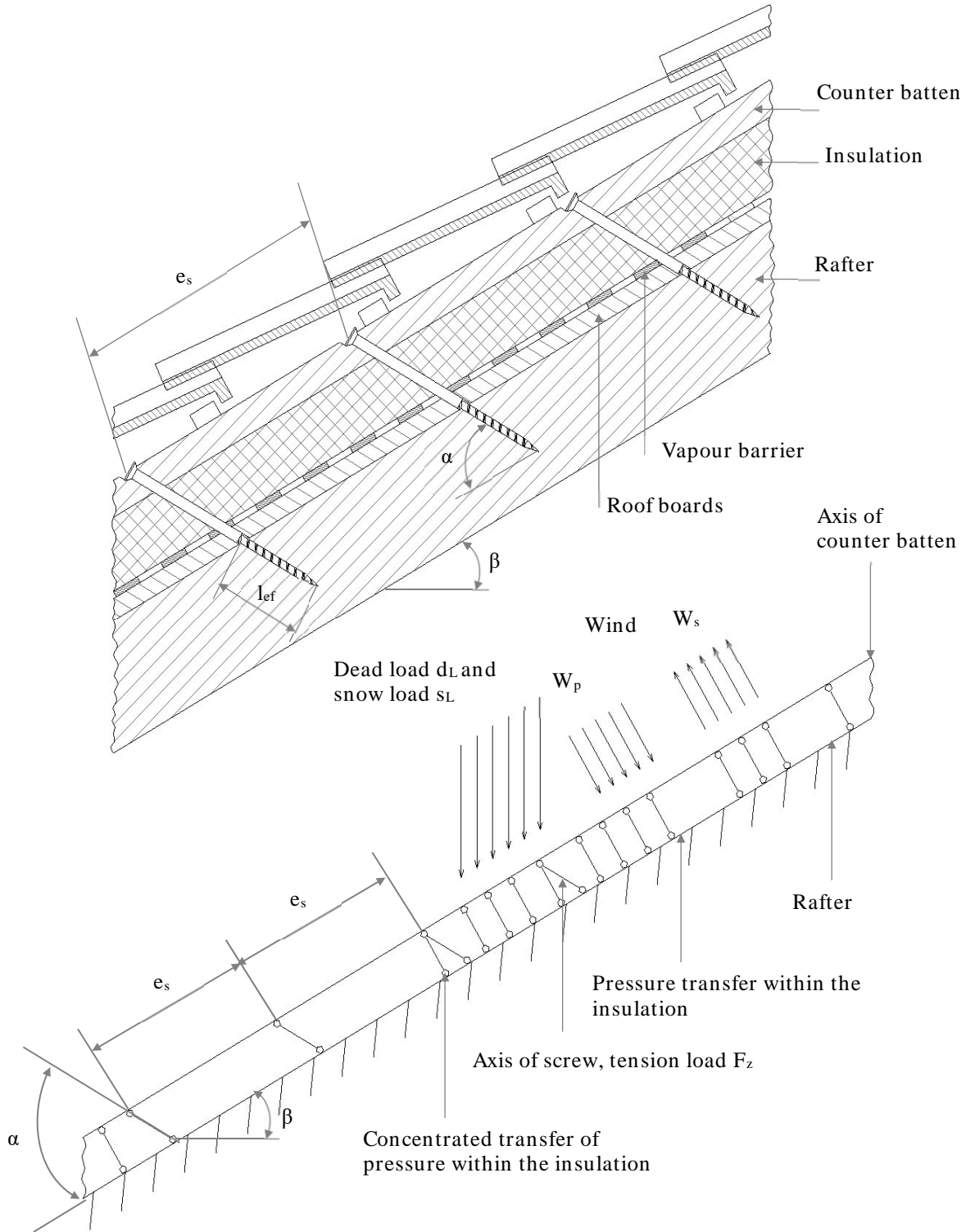

- | | | | | | |
|---------|---|-------------------|----------|---|--|
| W_s | = | Wind suction | W_p | = | Wind pressure |
| e_s | = | Spacing of screws | l_{ef} | = | Thread part part of screw in rafter |
| β | = | Roof inclination | α | = | Angle between axis of screw and axis of rafter |

fischer Power-Fast and Construction Screws	Annex B1 of European Technical Assessment ETA-11/0027
Accessories	

Annex B2
Fixing of on-roof insulation system
Point loads F_b perpendicular to the battens

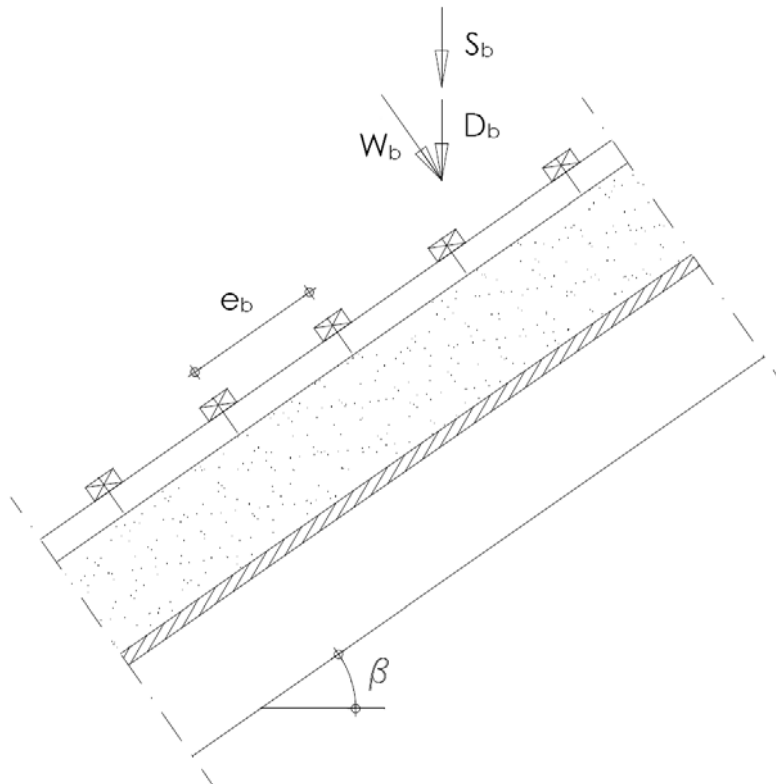

$$D_b = d \cdot e_b \cdot e_r$$
$$S_b = s \cdot e_b \cdot e_r \cdot \cos \beta$$
$$W_b = w_p \cdot e_b \cdot e_r$$
$$F_b = W_b + (D_b + S_b) \cdot \cos \beta$$

where

D_b = point load by dead load
 S_b = point load by snow load
 W_b = point load perpendicular to the batten by wind load (pressure)
 e_b = distance of the battens
 e_r = distance of the rafters
 s = snow load per m^2 ground area
 w_p = wind pressure on the roof area
 d = dead load per m^2 roof area
 β = roof angle

fischer Power-Fast and Construction Screws	Annex B2
Accessories	of European Technical Assessment ETA-11/0027

Point loads F_s perpendicular to the battens by screws

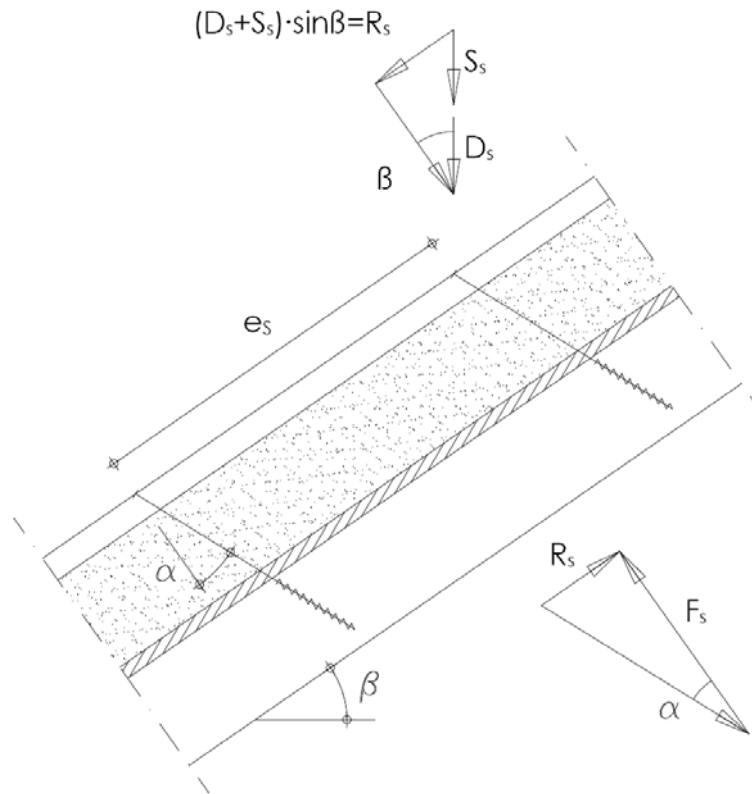

$$D_s = d \cdot e_s \cdot e_r$$

$$S_s = s \cdot e_s \cdot e_r \cdot \cos \beta$$

$$R_s = (D_s + S_s) \cdot \sin \beta$$

$$F_s = R_s / \tan \alpha$$

where

- D_s = point load by dead load
- S_s = point load by snow load
- R_s = shear load of the roof by dead load and snow load
- e_s = distance of the screws
- e_r = distance of the rafters
- α = angle between screw axis and perpendicular to rafter axis

fischer Power-Fast and Construction Screws	Annex B2 of European Technical Assessment ETA-11/0027
Accessories	

Appendix 37 / 41

Design of the battens

The bending stresses are calculated as:

$$M = \frac{(F_b + F_s) \cdot \ell_{\text{char}}}{4}$$

Where

$$\ell_{\text{char}} = \text{characteristic length } \ell_{\text{char}} = \sqrt[4]{\frac{4 \cdot EI}{w_{\text{ef}} \cdot K}}$$

EI = bending stiffness of the batten

K = coefficient of subgrade

w_{ef} = effective width of the heat insulation

F_b = Point loads perpendicular to the battens

F_s = Point loads perpendicular to the battens, load application in the area of the screw heads

The coefficient of subgrade K may be calculated from the modulus of elasticity E_{HI} and the thickness t_{HI} of the heat insulation if the effective width w_{ef} of the heat insulation under compression is known. Due to the load extension in the heat insulation the effective width w_{ef} is greater than the width of the batten or rafter, respectively. For further calculations, the effective width w_{ef} of the heat insulation may be determined according to:

$$w_{\text{ef}} = w + t_{\text{HI}} / 2$$

where

w = minimum width of the batten or rafter, respectively

t_{HI} = thickness of the heat insulation

$$K = \frac{E_{\text{HI}}}{t_{\text{HI}}}$$

The following condition shall be satisfied:

$$\frac{\sigma_{\text{m,d}}}{f_{\text{m,d}}} = \frac{M_{\text{d}}}{W \cdot f_{\text{m,d}}} \leq 1$$

For the calculation of the section modulus W the net cross section has to be considered.

The shear stresses shall be calculated according to:

$$V = \frac{(F_b + F_s)}{2}$$

The following condition shall be satisfied:

$$\frac{\tau_{\text{d}}}{f_{\text{v,d}}} = \frac{1,5 \cdot V_{\text{d}}}{A \cdot f_{\text{v,d}}} \leq 1$$

For the calculation of the cross section area the net cross section has to be considered.

Design of the heat insulation

The compressive stresses in the heat insulation shall be calculated according to:

$$\sigma = \frac{1,5 \cdot F_b + F_s}{2 \cdot \ell_{\text{char}} \cdot W}$$

The design value of the compressive stress shall not be greater than 110 % of the compressive stress at 10 % deformation calculated according to EN 826.

fischer Power-Fast and Construction Screws	Annex B2 of European Technical Assessment ETA-11/0027
Accessories	

Appendix 38 / 41

Design of the screws

The screws are loaded predominantly axially. The axial tension force in the screw may be calculated from the shear loads of the roof R_s :

$$T_s = \frac{R_s}{\cos \alpha}$$

The load-carrying capacity of axially loaded screws is the minimum design value of the axial withdrawal capacity of the threaded part of the screw, the head pull-through capacity of the screw and the tensile capacity of the screw.

In order to limit the deformation of the screw head for heat insulation thicknesses over 200 mm or with compressive strength below 0,12 N/mm², respectively, the axial withdrawal capacity of the screws shall be reduced by the factors k_1 and k_2 :

$$F_{ax,\alpha,Rd} = \min \left\{ \begin{array}{l} k_{ax} \cdot f_{ax,d} \cdot d \cdot \ell_{ef} \cdot k_1 \cdot k_2 \left(\frac{\rho_k}{350} \right)^{0,8} \\ f_{head,d} \cdot d_h^2 \cdot \left(\frac{\rho_k}{350} \right)^{0,8} \end{array} \right.$$

where:

- $f_{ax,d}$ design value of the axial withdrawal parameter of the threaded part of the screw
- d outer thread diameter of the screw
- ℓ_{ef} Point side penetration length of the threaded part of the screw in the rafter, $\ell_{ef} \geq 40$ mm
- α Angle between grain and screw axis ($\alpha \geq 30^\circ$)
- ρ_k characteristic density of the wood-based member [kg/m³]
- $f_{head,d}$ design value of the head pull-through capacity of the screw
- d_h head diameter
- k_1 $\min \{1; 200/t_{HI}\}$
- k_2 $\min \{1; \sigma_{10\%}/0,12\}$
- t_{HI} thickness of the heat insulation [mm]
- $\sigma_{10\%}$ compressive stress of the heat insulation under 10 % deformation [N/mm²]

If equation k_1 and k_2 are considered, the deflection of the battens does not need to be considered. Alternatively to the battens, panels with a minimum thickness of 20 mm from plywood according to EN 636 or an ETA or national provisions that apply at the installation site, particle board according to EN 312 or an ETA or national provisions that apply at the installation site, oriented strand board according to EN 300 or an ETA or national provisions that apply at the installation site and solid wood panels according to EN 13353 or an ETA or national provisions that apply at the installation site or cross laminated timber according to an ETA may be used.

fischer Power-Fast and Construction Screws	Annex B2 of European Technical Assessment ETA-11/0027
Accessories	

Appendix 39 / 41

Thermal insulation material on rafters with parallel screws perpendicular to the roof plane

Alternatively to the battens, panels with a minimum thickness of 20 mm from plywood according to EN 636, particleboard according to EN 312, oriented strand board OSB/3 and OSB/4 according to EN 300 or European Technical Approval and solid wood panels according to EN 13353 may be used.

Characteristic load-carrying capacity of a screw loaded in shear:

$$F_{v,Rk} = \min \left\{ \begin{array}{l} f_{h,b,k} \cdot d \cdot t_b \\ f_{h,r,k} \cdot d \cdot t_r \\ \frac{f_{h,b,k} \cdot d \cdot \beta}{1 + \beta} \cdot \left(\sqrt{4t_{il}^2 + \left(2 + \frac{1}{\beta}\right)t_b^2 + (2 + \beta)t_r^2 + 4t_{il}(t_b + t_r) + 2t_b t_r - 2t_{il} - t_b - t_r} \right) + \frac{F_{ax,Rk}}{4} \\ 1,05 \cdot \frac{f_{h,b,k} \cdot d \cdot \beta}{\frac{1}{2} + \beta} \left(\sqrt{t_{il}^2 + t_{il}t_b + \frac{t_b^2}{2} \left(1 + \frac{1}{\beta}\right) + \frac{M_{y,k}}{f_{h,b,k}d} \left(1 + \frac{2}{\beta}\right)} - t_{il} - \frac{t_b}{2} \right) + \frac{F_{ax,Rk}}{4} \\ 1,05 \cdot \frac{f_{h,b,k} \cdot d \cdot \beta}{\frac{1}{2} + \beta} \left(\sqrt{t_{il}^2 + t_{il}t_r + \frac{t_r^2}{2} (1 + \beta) + \frac{M_{y,k}}{f_{h,b,k}d} \left(2 + \frac{1}{\beta}\right)} - t_{il} - \frac{t_r}{2} \right) + \frac{F_{ax,Rk}}{4} \\ 1,15 \cdot \frac{f_{h,b,k} \cdot d}{1 + \beta} \left(\sqrt{\beta^2 t_{il}^2 + 4\beta(\beta + 1) \cdot \frac{M_{y,k}}{f_{h,b,k}d}} - \beta t_{il} \right) + \frac{F_{ax,Rk}}{4} \end{array} \right.$$

Where:

$f_{h,b,k}$	Characteristic batten embedding strength [N/mm ²]
$f_{h,r,k}$	Characteristic rafter embedding strength [N/mm ²]
β	$f_{h,r,k}/f_{h,b,k}$
d	Outer thread diameter [mm]
t_b	Batten thickness [mm]
t_r	The lower value of rafter thickness or screw penetration length [mm]
t_{il}	Interlayer thickness [mm]
$M_{y,k}$	Characteristic fastener yield moment [Nmm]
$F_{ax,Rk}$	Characteristic axial tensile capacity of the screw [N]

fischer Power-Fast and Construction Screws	Annex B2
Accessories	of European Technical Assessment ETA-11/0027

Appendix 40 / 41

Annex C
Minimum distances and spacing

Axially or laterally loaded screws in the plane surface or edge surface of cross laminated timber

Definition of spacing, end and edge distances in the plane surface unless otherwise specified in the technical specification (ETA or hEN) for the cross laminated timber:

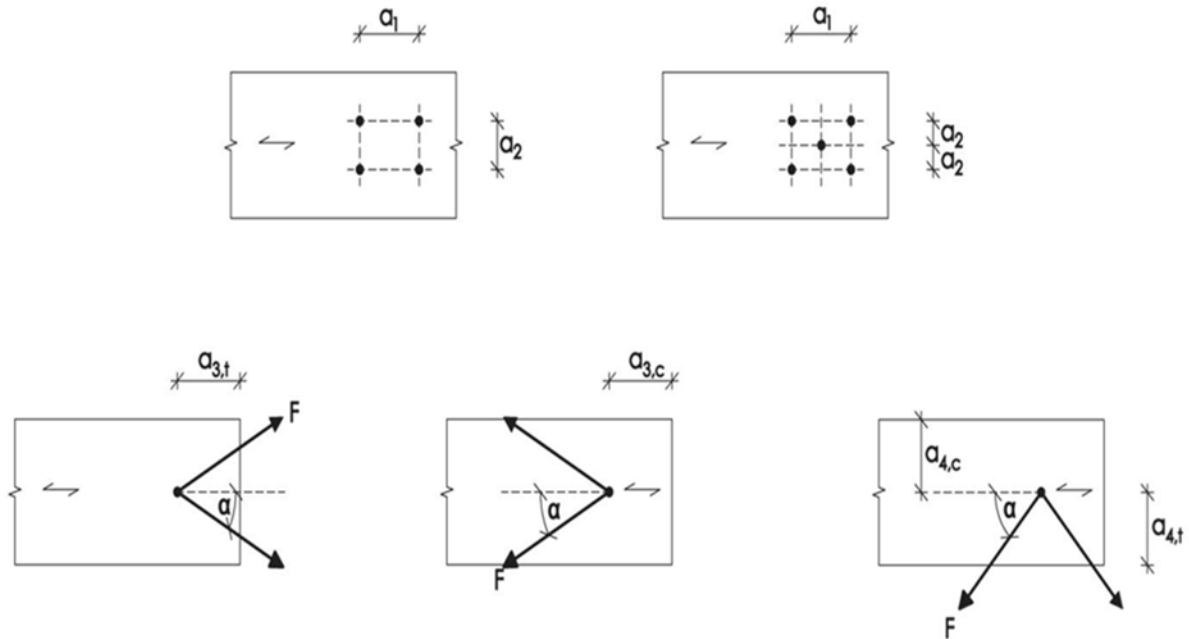

Definition of spacing, end and edge distances in the edge surface unless otherwise specified in the technical specification (ETA or hEN) for the cross laminated timber.

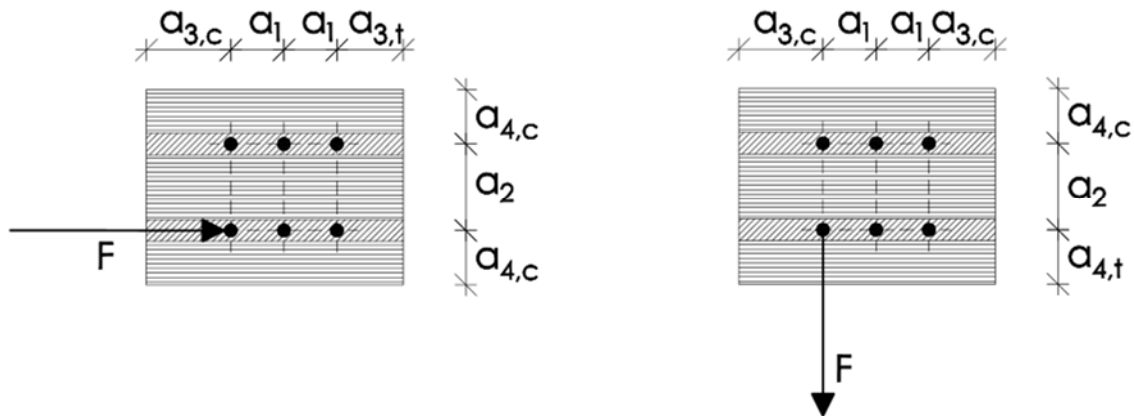

For screws in the edge surface, a_1 and a_3 are parallel to the CLT plane surface, a_2 and a_4 perpendicular to CLT plane surface.

Table C1: Minimum spacing, end and edge distances of screws in the plane or edge surfaces of cross laminated timber

	a_1	$a_{3,t}$	$a_{3,c}$	a_2	$a_{4,t}$	$a_{4,c}$
Plane surface (see Figure 1)	$4 \cdot d$	$6 \cdot d$	$6 \cdot d$	$2,5 \cdot d$	$6 \cdot d$	$2,5 \cdot d$
Edge surface (see Figure 2)	$10 \cdot d$	$12 \cdot d$	$7 \cdot d$	$4 \cdot d$	$6 \cdot d$	$3 \cdot d$

fischer Power-Fast and Construction Screws	Annex C of European Technical Assessment ETA-11/0027
Minimum distances and spacings	

Appendix 41 / 41

Annex D

Visualisation of the Power-Fast screw head clamped between two metal plates

Metric screws with hexagon head, countersunk head or cylindric head or threaded rods with nut and washer – each according to the structural requirements – at least 2xM8 (≥ 4.6 respectively A2-50) for the connection of the two plates made of aluminium (mechanical properties at least like e.g. EN AW 6082, EN AW 5083, EN AW 6060 or EN AC-44100); made of carbon steel or made of stainless steel (each at least S235).

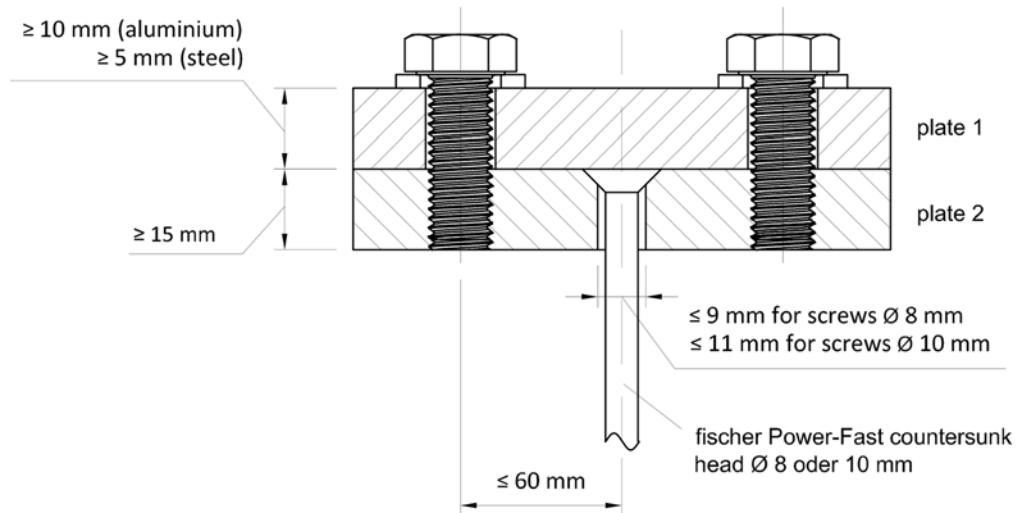

Information for the structural analysis of the metric screw connection and the metal plates are not part of this European Technical Assessment.

(Fig. not to scale)

<p>fischer Power-Fast and Construction Screws</p>	<p>Annex D of European Technical Assessment ETA-11/0027</p>
<p>clamping of the screw head for compression impact</p>	



LEISTUNGSERKLÄRUNG



Nr. 0045 – DE

1. Eindeutiger Kenncode des Produkttyps: **fischer Power-Fast screws and fischer construction screws**

2. Verwendungszweck(e):

Produkt	Verwendungszweck (e)
Schrauben zur Verwendung in Holzkonstruktionen	Schrauben zur Verwendung in tragenden Holzkonstruktionen, oder für Befestigung von Aufdachdämmsystemen auf Sparren, siehe Anhang.

3. Hersteller: **fischerwerke GmbH & Co. KG, Klaus-Fischer-Straße 1, 72178 Waldachtal, Deutschland**

4. Bevollmächtigter: --

5. System(e) zur Bewertung und Überprüfung der Leistungsbeständigkeit: 3

6a. Harmonisierte Norm: ---

Notifizierte Stelle(n): ---

6b. Europäisches Bewertungsdokument: **EAD 130118-00-0603**

Europäische Technische Bewertung: **ETA-11/0027; 2016-10-26**

Technische Bewertungsstelle: **ETA-Danmark A/S**

Notifizierte Stelle(n): **1343 – MPA Darmstadt**

7. Erklärte Leistung(en):

Mechanische Festigkeit und Standsicherheit (BWR 1)

Wesentliches Merkmal	Leistung
Zugfestigkeit	Siehe Anhang, insbesondere Anhang Seite 5
Einschraubmoment	Siehe Anhang, insbesondere Anhang Seite 5
Torsionsfestigkeit	Siehe Anhang, insbesondere Anhang Seite 5

Brandschutz (BWR 2)

Wesentliches Merkmal	Leistung
Brandverhalten	Der Dübel erfüllt die Anforderungen der Klasse A 1

8. Angemessene Technische Dokumentation und/oder Spezifische Technische Dokumentation: ---

Die Leistung des vorstehenden Produkts entspricht der erklärten Leistung/den erklärten Leistungen. Für die Erstellung der Leistungserklärung im Einklang mit der Verordnung (EU) Nr. 305/2011 ist allein der obengenannte Hersteller verantwortlich.

Unterzeichnet für den Hersteller und im Namen des Herstellers von:

Andreas Bucher, Dipl.-Ing.

Wolfgang Hengesbach, Dipl.-Ing., Dipl.-Wirtsch.-Ing.

Tumlingen, 2016-11-03

- Diese Leistungserklärung wurde in verschiedenen Sprachversionen erstellt. Für den Fall unterschiedlicher Auslegung hat immer die englische Version Vorrang.

- Der Anhang enthält freiwillige und ergänzende Informationen in englischer Sprache. Diese gehen über die (sprachneutral angegebenen) gesetzlichen Anforderungen hinaus.

II SPECIFIC PART OF THE EUROPEAN TECHNICAL ASSESSMENT

1 Technical description of product and intended use

Technical description of the product

“fischer Power-Fast” and “fischer construction screws” are self-tapping screws to be used in timber structures. “fischer Power-Fast” screws shall be threaded over a part or over the full length. “fischer construction screws” shall be threaded over a part of the length. The screws shall be produced from carbon steel wire for nominal diameters of 3,0 mm to 12,0 mm and from stainless steel wire for nominal diameters of 3,0 mm to 8,0 mm. The material specification of the stainless steel screws is deposited with ETA-Danmark. Where corrosion protection is required, the material or coating shall be declared in accordance with the relevant specification given in Annex A of EN 14592.

Geometry and Material

The nominal diameter (outer thread diameter), d , shall not be less than 3,0 mm and shall not be greater than 12,0 mm. The overall length, L , of screws shall not be less than 20 mm and shall not be greater than 600 mm. Other dimensions are given in Annex A1 to Annex A18.

The ratio of inner thread diameter to outer thread diameter d_i/d ranges from 0,59 to 0,69.

The screws are threaded over a minimum length ℓ_g of $4,0 \cdot d$ (i.e. $\ell_g \geq 4,0 \cdot d$).

The lead p (distance between two adjacent thread flanks) ranges from $0,50 \cdot d$ to $0,67 \cdot d$.

No breaking of screws shall be observed at a bend angle, α , of less than $(45/d^{0,7} + 20)$ degrees.

The material specification of the of the stainless steel screws is deposited with ETA-Danmark.

2 Specification of the intended use in accordance with the applicable EAD

The screws are used for connections in load bearing timber structures between members of solid timber (softwood and hardwood). Furthermore, all kinds of processed timber products (all softwood and hardwood as well), such as glued laminated timber, cross-laminated timber, laminated veneer lumber, similar glued members, wood-based panels or steel.

Furthermore “fischer Power-Fast” screws with diameter of 6 mm, 8 mm, 10 mm and 12 mm may also be used for the fixing of heat insulation on rafters and on vertical facades.

Steel plates and wood-based panels except solid wood panels and cross laminated timber shall only be located on the side of the screw head. The following wood-based panels may be used:

- Plywood according to EN 636 or ETA
- Particleboard according to EN 312 or ETA
- Oriented Strand Board, Type OSB/3 and OSB/4 according to EN 300 or ETA
- Fibreboard according to EN 622-2 and 622-3 or ETA (minimum density 650 kg/m³)
- Cement bonded particleboard according to ETA
- Solid wood panels according to EN 13353 and EN 13986, and cross laminated timber according to ETA
- Laminated Veneer Lumber according to EN 14374 or ETA
- Engineered wood products according to ETA if the ETA of the product includes provisions for the use of self-tapping screws, the provisions of the ETA of the engineered wood product apply

The screws shall be screwed into softwood without pre-drilling or after pre-drilling with a diameter not larger than the inner thread diameter for the length of the threaded part and with a maximum of the smooth shank diameter for the length of the smooth shank. The screws shall be driven into hardwood after pre-drilling with a suitable diameter according to section 3.11.

The screws are intended to be used in timber connections for which requirements for mechanical resistance and stability and safety in use in the sense of the Basic Works Requirements 1 and 4 of Regulation 305/2011 shall be fulfilled.

Form and dimensions of washers are given in Annex A19. Washers must be made of steel.

The design of the connections shall be based on the characteristic load-carrying capacities of the screws. The design capacities shall be derived from the characteristic capacities in accordance with Eurocode 5 or an appropriate national code (e.g. DIN 1052:2008-12). Regarding environmental conditions, national provisions at the building site shall apply.

The screws are intended for use for connections subject to static or quasi static loading.

The zinc-coated screws are for use in timber structures subject to the dry, internal conditions defined by the

service classes 1 and 2 of EN 1995-1-1:2008 (Eurocode 5).

The screws made of stainless steel meet the requirements of Eurocode 5 (EN 1995-1-1:2008), for use in structures subject to the wet conditions defined as service class 3.

The scope of the screws regarding resistance to corrosion shall be defined according to national provisions that apply at the installation site considering environmental conditions.

The provisions made in this European Technical Assessment are based on an assumed intended working life of the screws of 50 years.

The indications given on the working life cannot be interpreted as a guarantee given by the producer or Assessment Body, but are to be regarded only as a means for choosing the right products in relation to the expected economically reasonable working life of the works.

3 Performance of the product and references to the methods used for its assessment

Characteristic	Assessment of characteristic
3.1 Mechanical resistance and stability*) (BWR1)	
Tensile strength	Characteristic value $f_{\text{tens},k}$:
Screws made from carbon steel	Screw d = 3,0 mm: 2,7 kN
	Screw d = 3,5 mm: 3,7 kN
	Screw d = 4,0 mm: 4,8 kN
	Screw d = 4,5 mm: 6,0 kN
	Screw d = 5,0 mm: 7,5 kN
	Screw d = 6,0 mm: 10,7 kN
	Screw d = 8,0 mm: 19,1 kN
	Screw d = 10,0 mm: 29,8 kN
	Screw d = 12,0 mm: 32,7 kN
Screws from stainless steel	Screw d = 3,0 mm: 1,6 kN
	Screw d = 3,5 mm: 2,1 kN
	Screw d = 4,0 mm: 2,8 kN
	Screw d = 4,5 mm: 3,5 kN
	Screw d = 5,0 mm: 4,3 kN
	Screw d = 6,0 mm: 6,2 kN
	Screw d = 8,0 mm: 13,0 kN
Insertion moment	Ratio of the characteristic torsional strength to the mean insertion moment: $f_{\text{tor},k} / R_{\text{tor,mean}} \geq 1,5$
Torsional strength	Characteristic value $f_{\text{tor},k}$:
Screws from carbon steel	Screw d = 3,0 mm: 1,3 Nm
	Screw d = 3,5 mm: 2,0 Nm
	Screw d = 4,0 mm: 3,0 Nm
	Screw d = 4,5 mm: 4,3 Nm
	Screw d = 5,0 mm: 6,0 Nm
	Screw d = 6,0 mm: 9,5 Nm
	Screw d = 8,0 mm: 25,0 Nm
	Screw d = 10,0 mm: 40,0 Nm
	Screw d = 12,0 mm: 55,0 Nm
Screws from stainless steel	Screw d = 3,0 mm: 0,9 Nm
	Screw d = 3,5 mm: 1,3 Nm
	Screw d = 4,0 mm: 1,9 Nm
	Screw d = 4,5 mm: 2,6 Nm
	Screw d = 5,0 mm: 3,7 Nm
	Screw d = 6,0 mm: 6,5 Nm
	Screw d = 8,0 mm: 16,0 Nm
3.2 Safety in case of fire (BWR2)	
Reaction to fire	The screws are made from steel classified as Euroclass A1 in accordance with EN 13501-1 and Commission Delegated Regulation 2016/364.

Characteristic	Assessment of characteristic
3.3 Hygiene, health and the environment (BWR3)	
Influence on air quality	The product does not contain/release dangerous substances specified in TR 034, dated October 2015 (**)
3.7 Sustainable use of natural resources (BR7)	No Performance Assessed
3.8 General aspects related to the performance of the product	The screws have been assessed as having satisfactory durability and serviceability when used in timber structures using the timber species described in Eurocode 5 and subject to the conditions defined by service classes 1, 2 and 3
Identification	See Annex A

*) See additional information in section 3.9 – 3.12.

**) In addition to the specific clauses relating to dangerous substances contained in this European technical Assessment, there may be other requirements applicable to the products falling within its scope (e.g. transposed European legislation and national laws, regulations and administrative provisions). In order to meet the provisions of the Construction Products Regulation, these requirements need also to be complied with, when and where they apply.

3.9 Mechanical resistance and stability

The load-carrying capacities for “fischer Power-Fast” and “fischer construction screws” are applicable to the wood-based materials mentioned in paragraph 1 even though the term timber has been used in the following.

The characteristic lateral load-carrying capacities and the characteristic axial withdrawal capacities of ”fischer Power-Fast” and “fischer construction screws” screws should be used for designs in accordance with Eurocode 5 or an appropriate national code.

Pointside penetration length of the threaded part must be $\ell_{ef} \geq 4 \cdot d$, where d is the outer thread diameter of the screw. For the fixing of rafters, point side penetration must be at least 40 mm, $\ell_{ef} \geq 40$ mm.

ETA’s for structural members may be considered if applicable.

For wood-based panels the relevant ETAs must be considered where applicable.

Lateral load-carrying capacity

The characteristic lateral load-carrying capacity of “fischer Power-Fast” and “fischer construction screws” screws shall be calculated according to EN 1995-1-1:2008 (Eurocode 5) using the outer thread diameter d as the nominal diameter of the screw. The contribution from the rope effect may be considered.

The characteristic yield moment shall be calculated from:

Screws from carbon steel for $3,0 \text{ mm} \leq d \leq 5,0 \text{ mm}$ and $12,0 \text{ mm}$:

$$M_{y,k} = 0,15 \cdot 500 \text{ (N/mm}^2\text{)} \cdot d^{2,6} \quad [\text{Nmm}]$$

Screws from carbon steel for $6,0 \text{ mm} \leq d \leq 10,0 \text{ mm}$:

$$M_{y,k} = 0,15 \cdot 600 \text{ (N/mm}^2\text{)} \cdot d^{2,6} \quad [\text{Nmm}]$$

Screws from stainless steel for $3,0 \text{ mm} < d < 6,0 \text{ mm}$:

$$M_{y,k} = 0,15 \cdot 350 \text{ (N/mm}^2\text{)} \cdot d^{2,6} \quad [\text{Nmm}]$$

Screws from stainless steel for $d = 8,0 \text{ mm}$:

$$M_{y,k} = 0,15 \cdot 400 \text{ (N/mm}^2\text{)} \cdot d^{2,6} \quad [\text{Nmm}]$$

where

d outer thread diameter [mm]

The embedding strength for screws in non-pre-drilled holes arranged at an angle between screw axis and grain direction, $0^\circ \leq \alpha \leq 90^\circ$ is:

$$f_{h,k} = \frac{0,082 \cdot \rho_k \cdot d^{-0,3}}{2,5 \cdot \cos^2 \alpha + \sin^2 \alpha} \quad [\text{N/mm}^2]$$

and accordingly for screws in pre-drilled holes:

$$f_{h,k} = \frac{0,082 \cdot \rho_k \cdot (1 - 0,01 \cdot d)}{2,5 \cdot \cos^2 \alpha + \sin^2 \alpha} \quad [\text{N/mm}^2]$$

Where

ρ_k characteristic timber density [kg/m³];

d outer thread diameter [mm];

α angle between screw axis and grain direction.

The embedding strength for screws arranged parallel to the plane of cross laminated timber, independent of the angle between screw axis and grain direction, $0^\circ \leq \alpha \leq 90^\circ$, may be calculated from:

$$f_{h,k} = 20 \cdot d^{-0,5} \quad [\text{N/mm}^2]$$

Where

d outer thread diameter [mm]

The embedding strength for screws in the wide face of cross laminated timber should be assumed as for solid timber based on the characteristic density of the outer layer. If relevant, the angle between force and grain direction of the outer layer should be taken into account.

The direction of the lateral force shall be perpendicular to the screw axis and parallel to the wide face of the cross laminated timber.

Axial withdrawal capacity

The characteristic axial withdrawal capacity of „fischer Power-Fast” and “fischer construction screws” in solid timber (softwood and ash, beech or oak hardwood), glued laminated timber (softwood and hardwood, ash, beech or oak), laminated veneer lumber (softwood or hardwood beech) or cross-laminated timber members at an angle of $0^\circ \leq \alpha \leq 90^\circ$ to the grain shall be calculated from:

$$F_{ax,\alpha,Rk} = n_{ef} \cdot k_{ax} \cdot f_{ax,k} \cdot d \cdot \ell_{ef} \cdot \left(\frac{\rho_k}{350} \right)^{0,8} \quad [\text{N}]$$

Where

$F_{ax,\alpha,Rk}$ Characteristic withdrawal capacity of the connection at an angle α to the grain [N]

n_{ef} Effective number of screws according to EN 1995-1-1

For inclined screws: $n_{ef} = \max \{ n^{0,9}; 0,9 \cdot n \}$

k_{ax} Factor, taking into account the angle α between screw axis and grain direction

$k_{ax} = 1,0$ for $45^\circ \leq \alpha < 90^\circ$

$k_{ax} = 0,3 + \frac{0,7 \cdot \alpha}{45}$ for $0^\circ \leq \alpha < 45^\circ$

$f_{ax,k}$	Characteristic withdrawal parameter [N/mm ²]
screw d = 3,0 mm:	$f_{ax,k} = 13,8 \text{ N/mm}^2$
screw d = 3,5 mm:	$f_{ax,k} = 13,4 \text{ N/mm}^2$
screw d = 4,0 mm:	$f_{ax,k} = 13,0 \text{ N/mm}^2$
screw d = 4,5 mm:	$f_{ax,k} = 12,6 \text{ N/mm}^2$
screw d = 5,0 mm:	$f_{ax,k} = 12,2 \text{ N/mm}^2$
screw d = 6,0 mm:	$f_{ax,k} = 11,6 \text{ N/mm}^2$
screw d ≥ 8,0 mm:	$f_{ax,k} = 10,0 \text{ N/mm}^2$
d	Outer thread diameter [mm]
ℓ_{ef}	Point side penetration length of the threaded part according to EN 1995-1-1:2008 [mm]
α	Angle between grain and screw axis [°]
ρ_k	Characteristic density [kg/m ³], for hardwoods the assumed characteristic density shall not exceed 730 kg/m ³

For screws arranged under an angle between screw axis and grain direction of less than 90°, the minimum threaded penetration length is:

$$\ell_{ef} \geq \min(4 \cdot d / \sin \alpha ; 20 \cdot d)$$

For screws penetrating more than one layer of cross laminated timber, the different layers may be taken into account proportionally.

The axial withdrawal capacity is limited by the head pull-through capacity and the tensile strength of the screw.

For axially loaded screws in tension, where the external force is parallel to the screw axes, the rules in EN 1995-1-1, 8.7.2 (8) should be applied.

For inclined screws in timber-to-timber or steel-to-timber shear connections, where the screws are arranged under an angle $30^\circ \leq \alpha \leq 60^\circ$ between the shear plane and the screw axis, the effective number of screws n_{ef} should be determined as follows:

For one row of n screws parallel to the load, the load-carrying capacity should be calculated using the effective number of fasteners n_{ef} , where

$$n_{ef} = \max\{n^{0,9} ; 0,9 \cdot n\}$$

and n is the number of inclined screws in a row. If crossed pairs of screws are used in timber-to-timber connections, n is the number of crossed pairs of screws in a row.

Note: For inclined screws as fasteners in mechanically jointed beams or columns or for the fixing of thermal insulation material, $n_{ef} = n$.

Head pull-through capacity

The characteristic head pull-through capacity of “fischer Power-Fast” and “fischer construction screws” shall be calculated according to EN 1995-1-1:2008 from:

$$F_{ax,\alpha,Rk} = n_{ef} \cdot f_{head,k} \cdot d_h^2 \cdot \left(\frac{\rho_k}{350}\right)^{0,8} \quad [N]$$

where:

$F_{ax,\alpha,Rk}$ characteristic head pull-through capacity of the connection at an angle $\alpha \geq 30^\circ$ to the grain [N]

n_{ef} effective number of screws according to EN 1995-1-1

For inclined screws: $n_{ef} = \max\{n^{0,9} ; 0,9 \cdot n\}$ (see axial withdrawal capacity)

$f_{head,k}$ characteristic head pull-through parameter [N/mm²]

d_h diameter of the screw head [mm]

ρ_k characteristic density [kg/m³], for wood-based panels $\rho_k = 380 \text{ kg/m}^3$

Characteristic head pull-through parameter for screws with head diameter $\leq 21 \text{ mm}$ in connections with timber and with wood-based panels with thicknesses above 20 mm:

$$f_{head,k} = 12 \text{ N/mm}^2$$

Characteristic head pull-through parameter for screws with head diameter $21 \text{ mm} < d_h \leq 35 \text{ mm}$ in connections with timber and with wood-based panels with thicknesses above 20 mm:

$$f_{head,k} = 10 \text{ N/mm}^2$$

Characteristic head pull-through parameter for screws in connections with wood-based panels with thicknesses between 12 mm and 20 mm:

$$f_{head,k} = 8 \text{ N/mm}^2$$

Screws in connections with wood-based panels with a thickness below 12 mm (minimum thickness of the wood based panels of $1,2 \cdot d$ with d as outer thread diameter):

$$f_{head,k} = 8 \text{ N/mm}^2$$

limited to $F_{ax,\alpha,Rk} = 400 \text{ N}$

The head diameter d_h shall be greater than $1,8 \cdot d_s$, where d_s is the smooth shank or the wire diameter. Otherwise the characteristic head pull-through capacity $F_{ax,\alpha,Rk} = 0$.

Outer diameter of washers $d_h > 35 \text{ mm}$ shall not be considered.

The minimum thickness of wood-based panels according to the clause 3.9 must be observed.

In steel-to-timber connections the head pull-through capacity is not decisive.

Tensile capacity

The characteristic tensile strength $f_{tens,k}$ of “fischer Power-Fast” and “fischer construction screws” is:

Screws from carbon steel:

Screw d = 3,0 mm:	2,7 kN
Screw d = 3,5 mm:	3,7 kN
Screw d = 4,0 mm:	4,3 kN
Screw d = 4,5 mm:	5,5 kN
Screw d = 5,0 mm:	6,8 kN
Screw d = 6,0 mm:	10,7 kN
Screw d = 8,0 mm:	19,1 kN
Screw d = 10,0 mm:	29,8 kN
Screw d = 12,0 mm:	32,7 kN

Screws from stainless steel:

Screw d = 3,0 mm:	1,6 kN
Screw d = 3,5 mm:	2,1 kN
Screw d = 4,0 mm:	2,8 kN
Screw d = 4,5 mm:	3,5 kN
Screw d = 5,0 mm:	4,3 kN
Screw d = 6,0 mm:	6,2 kN
Screw d = 8,0 mm:	13,0 kN

For screws used in combination with steel plates, the tear-off capacity of the screw head should be greater than the tensile strength of the screw.

Combined laterally and axially loaded screws

For screwed connections subjected to a combination of axial load and lateral load, the following expression should be satisfied:

$$\left(\frac{F_{ax,Ed}}{F_{ax,Rd}}\right)^2 + \left(\frac{F_{la,Ed}}{F_{la,Rd}}\right)^2 \leq 1$$

where

$F_{ax,Ed}$	axial design load of the screw
$F_{la,Ed}$	lateral design load of the screw
$F_{ax,Rd}$	design load-carrying capacity of an axially loaded screw
$F_{la,Rd}$	design load-carrying capacity of a laterally loaded screw

Slip modulus

The axial slip modulus K_{ser} of a screw for the serviceability limit state should be taken independent of angle α to the grain as:

$$C = K_{ser} = 780 \cdot d^{0,2} \cdot \ell_{ef}^{0,4} \quad [N/mm]$$

Where

d	outer thread diameter [mm]
ℓ_{ef}	penetration length in the structural member [mm]

Thermal insulation material on top of rafters

“fischer Power-Fast” screws with an outer thread diameter of d = 6 mm, 8 mm, 10 mm and 12 mm may be used for the fixing of thermal insulation material on top of rafters.

The thickness of the insulation ranges up to 400 mm. The rafter insulation must be placed on top of solid timber or glued laminated timber rafters or cross-laminated timber members and be fixed by battens placed parallel to the rafters or by wood-based panels on top of the insulation layer. The insulation of vertical facades is also covered by the rules given here.

Screws must be screwed in the rafter through the battens or panels and the insulation without pre-drilling in one sequence.

The angle α between the screw axis and the grain direction of the rafter should be between 30° and 90°.

The battens must be from solid timber (softwood) according to EN 338:2003-04. The minimum thickness of the battens is 80 mm and the minimum width 100 mm for screws with outer thread diameter d = 12 mm. The minimum thickness of the battens is 40 mm and the minimum width 60 mm for screws with outer thread diameter d = 10 mm. For screws with outer thread diameter d = 6 mm and 8 mm the minimum thickness of the battens is 30 mm and the minimum width 50 mm.

Alternatively to the battens, boards with a minimum thickness of 20 mm from plywood according to EN 636, particle board according to EN 312, oriented strand board OSB/3 and OSB/4 according to EN 300 or ETA and solid wood panels according to EN 13353 may be used.

The rafter consists of solid timber (softwood) according to EN 338, glued laminated timber according to EN 14081, cross-laminated timber, laminated veneer lumber according to EN 14374 or to ETA or similar glued members according to ETA and has a minimum width of 60 mm.

The insulation must comply with a ETA.

The insulation must have a minimum compressive stress of $\sigma_{10\%} = 0,05 \text{ N/mm}^2$ at 10 % deformation according to EN 826:1996-05.

The analysis of the fixing of the insulation and battens or boards, respectively, may be carried out using the static model in Annex B. The battens or boards, respectively, must have sufficient strength and stiffness. The maximum pressure between the battens or boards, respectively, and the insulation shall not exceed $1,1 \cdot \sigma_{10\%}$.

The characteristic axial withdrawal capacity of the screws for rafter or facade insulation shall be calculated from:

$$F_{ax,\alpha,Rk} = \min \left\{ \begin{array}{l} k_{ax} * f_{ax,k} * d * l_{ef} * k_1 * k_2 * \left(\frac{\rho_k}{350}\right)^{0,8} \\ f_{head,k} * d_h^2 * \left(\frac{\rho_k}{350}\right)^{0,8} \\ f_{tens,k} \end{array} \right. \quad [N]$$

where

$F_{ax,\alpha,Rk}$	Characteristic withdrawal capacity of the connection at an angle α to the grain [N]
k_{ax}	Factor, taking into account the angle α between screw axis and grain direction $k_{ax} = 1,0$ for $45^\circ \leq \alpha < 90^\circ$ $k_{ax} = 0,3 + \frac{0,7 \cdot \alpha}{45}$ for $0^\circ \leq \alpha < 45^\circ$
$f_{ax,k}$	Characteristic withdrawal parameter [N/mm ²]
d	Outer thread diameter [mm]
l_{ef}	Point side penetration length of the threaded part according to EN 1995-1-1:2008 [mm]
α	Angle between grain and screw axis ($\alpha \geq 30^\circ$)
k_1	$\min \{1; 220/t_{HI}\}$
k_2	$\min \{1; \sigma_{10\%}/0,12\}$
t_{HI}	Thickness of the thermal insulation [mm]
$\sigma_{10\%}$	Compressive stress of the thermal insulation under 10 % deformation [N/mm ²] $\sigma_{10\%} \geq 0,05$ N/mm ²
$f_{head,k}$	Characteristic head pull-through parameter [N/mm ²]
d_h	Outer diameter of the screw head [mm]
ρ_k	Characteristic density [kg/m ³]
$f_{tens,k}$	Characteristic tensile capacity of the screw [N]

Friction forces shall not be considered for the design of the characteristic axial withdrawal capacity of the screws.

The anchorage of wind suction forces as well as the bending stresses of the battens or the boards, respectively, shall be considered in design. Additional screws perpendicular to the grain of the rafter (angle $\alpha = 90^\circ$) may be arranged if necessary.

Screws for the anchorage of rafter insulation shall be arranged according to Annex B.

The maximum screw spacing is $e_s = 1,75$ m.

3.10 Aspects related to the performance of the product

3.10.1 Corrosion protection in service class 1, 2 and 3.

The fischer Power-Fast and fischer construction screws are produced from carbon wire. Screws made from carbon steel are electrogalvanised and yellow or blue chromate. The mean thickness of the zinc coating is 5 μ m.

The material specification of the stainless steel screws is deposited with ETA-Danmark.

3.11 General aspects related to the intended use of the product

The screws are manufactured in accordance with the provisions of the European Technical Assessment using the automated manufacturing process and laid down in the technical documentation.

The installation shall be carried out in accordance with Eurocode 5 or an appropriate national code unless otherwise is defined in the following. Instructions from fischerwerke GmbH & Co. KG should be considered for installation.

The screws are used for connections in load bearing timber structures between members of solid timber (softwood and hardwood), glued laminated timber (softwood and hardwood), cross-laminated timber (minimum diameter $d = 6,0$ mm, softwood and hardwood), laminated veneer lumber (softwood and hardwood), similar glued members (softwood and hardwood), wood-based panels or steel members.

The screws may be used for connections in load bearing timber structures with structural members according to an associated ETA, if according to the ETA of the structural member a connection in load bearing timber structures with screws according to an ETA is allowed.

Furthermore, the screws with diameters between 6 mm and 12 mm may also be used for the fixing of insulation on top of rafters or at vertical facades.

A minimum of two screws should be used for connections in load bearing timber structures.

The minimum penetration depth in structural members made of solid, glued or cross-laminated timber is 4·d.

Wood-based panels and steel plates should only be arranged on the side of the screw head. The minimum thickness of wood-based panels should be 1,2·d. Furthermore, the minimum thickness for following wood-based panels should be:

- Plywood, Fibreboards: 6 mm
- Particleboards, OSB, Cement Particleboards: 8 mm
- Solid wood panels: 12 mm

For structural members according to ETA's the terms of the ETA's must be considered.

If screws with an outer thread diameter $d \geq 8$ mm are used in load bearing timber structures, the structural solid or glued laminated timber, laminated veneer lumber and similar glued members must be from spruce, pine or fir. This does not apply for screws in pre-drilled holes.

The minimum angle between the screw axis and the grain direction is $\alpha = 0^\circ$.

The screws shall be driven into softwood without predrilling or after pre-drilling. The screws shall be driven into hardwood with a maximum characteristic density of 730 kg/m^3 after predrilling.

The drill hole diameters are:

Outer thread diameter	Drill hole diameter	
	Softwood	Hardwood
4,0	2,5	3,0
4,5	2,5	3,0
5,0	3,0	3,0
6,0	4,0	4,0
8,0	5,0	6,0
10,0	6,0	7,0
12,0	7,0	8,0

The hole diameter in steel members must be predrilled with a suitable diameter.

Only the equipment prescribed by fischerwerke GmbH & Co. KG shall be used for driving the screws.

In connections with screws with countersunk head according to Annexes A1, A5, A6, A7, A11, A13 and A17, the head must be flush with the surface of the connected structural member. A deeper countersink is not allowed.

Screws from carbon steel and stainless steel with countersunk head according to Annex A1, A2, A5, A6, A7, A11, A13, A14 and A17 may be used together with washers according to Annex A19. Washers according to EN ISO 7094 may be used together with washers according to Annex A19.

Screws according to Annex A3, A4, A8, A9, A10, A12 A15, A16 and A18 may be used together with washers according to EN ISO 7094.

Washers from carbon steel should be used with screws from carbon steel and screws from stainless steel with washers from stainless steel. Washers should have a full bearing area.

For structural timber members, minimum spacing and distances for screws in predrilled holes are given in EN 1995-1-1:2008 (Eurocode 5) clause 8.3.1.2 and table 8.2 as for nails in predrilled holes. Here, the outer thread diameter d must be considered.

For screws in non-predrilled holes, minimum spacing and distances are given in EN 1995-1-1:2008 (Eurocode 5) clause 8.3.1.2 and table 8.2 as for nails in non-predrilled holes.

Alternatively, minimum distances and spacing for exclusively axially loaded “fischer Power-Fast” screws in non-predrilled holes in members of solid timber (softwood and hardwood), glued laminated timber or similar glued products (softwood and hardwood) with a minimum thickness $t = 12 \cdot d$ and a minimum width of $8 \cdot d$ or 60 mm, whichever is the greater, may be taken as:

Spacing a_1 parallel to the grain $a_1 = 5 \cdot d$
 Spacing a_2 perpendicular to the grain $a_2 = 5 \cdot d$
 Distance $a_{3,c}$ from centre of the screw-part in timber to the end grain $a_{3,c} = 9 \cdot d$
 Distance $a_{4,c}$ from centre of the screw-part in timber to the edge $a_{4,c} = 4 \cdot d$

Spacing a_2 perpendicular to the grain may be reduced from $5 \cdot d$ to $2,5 \cdot d$, if the condition $a_1 \cdot a_2 \geq 25 \cdot d^2$ is fulfilled.

For Douglas fir members minimum spacing and distances parallel to the grain shall be increased by 50%.

Minimum distances from loaded or unloaded ends must be $15 \cdot d$ for screws in non-predrilled holes with outer thread diameter $d \geq 8 \text{ mm}$ and timber thickness $t < 5 \cdot d$.

Minimum distances from the unloaded edge perpendicular to the grain may be reduced to $3 \cdot d$ also for timber thickness $t < 5 \cdot d$, if the spacing parallel to the grain and the end distance is at least $25 \cdot d$.

Unless specified otherwise in the technical specification (ETA or hEN) of cross laminated timber, minimum distances and spacing for screws in the wide face of cross laminated timber members with a minimum thickness $t = 10 \cdot d$ may be taken as (see Annex C):

Spacing a_1 parallel to the grain $a_1 = 4 \cdot d$
 Spacing a_2 perpendicular to the grain $a_2 = 2,5 \cdot d$
 Distance $a_{3,c}$ from centre of the screw-part in timber to the unloaded end grain $a_{3,c} = 6 \cdot d$
 Distance $a_{3,t}$ from centre of the screw-part in timber to the loaded end grain $a_{3,t} = 6 \cdot d$
 Distance $a_{4,c}$ from centre of the screw-part in timber to the unloaded edge $a_{4,c} = 2,5 \cdot d$
 Distance $a_{4,t}$ from centre of the screw-part in timber to the loaded edge $a_{4,t} = 6 \cdot d$

Unless specified otherwise in the technical specification (ETA or hEN) of cross laminated timber, minimum distances and spacing for screws in the edge surface of cross laminated timber members with a minimum thickness $t = 10 \cdot d$ and a minimum penetration depth perpendicular to the edge surface of $10 \cdot d$ may be taken as (see Annex C):

Spacing a_1 parallel to the CLT plane $a_1 = 10 \cdot d$
 Spacing a_2 perpendicular to the CLT plane $a_2 = 4 \cdot d$
 Distance $a_{3,c}$ from centre of the screw-part in

timber to the unloaded end	$a_{3,c} = 7 \cdot d$
Distance $a_{3,t}$ from centre of the screw-part in	
timber to the loaded end	$a_{3,t} = 12 \cdot d$
Distance $a_{4,c}$ from centre of the screw-part in	
timber to the unloaded edge	$a_{4,c} = 3 \cdot d$
Distance $a_{4,t}$ from centre of the screw-part in	
timber to the loaded edge	$a_{4,t} = 6 \cdot d$

For a crossed screw couple the minimum spacing between the crossing screws is $1,5 \cdot d$.

Minimum thickness for structural members is $t = 24$ mm
for screws with outer thread diameter $d < 8$ mm, $t = 30$ mm
for screws with outer thread diameter $d = 8$ mm, $t = 40$ mm
for screws with outer thread diameter $d = 10$ mm and $t = 80$ mm for screws with outer thread diameter $d = 12$ mm.

4 Attestation and verification of constancy of performance (AVCP)

4.1 AVCP system

According to the decision 97/176/EC of the European Commission¹, as amended, the system(s) of assessment and verification of constancy of performance (see Annex V to Regulation (EU) No 305/2011) is 3.

Screw sizes and material

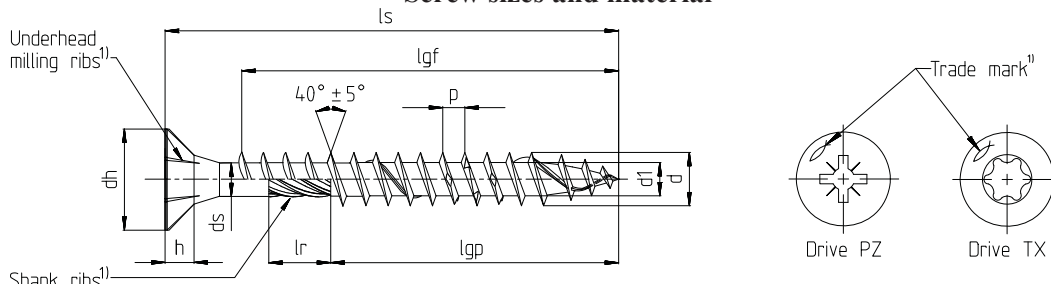

1) optional

Power-Fast self-drilling screw - Countersunk head with full- or partial thread

- Carbon Steel
- Possible surface treatments: yellow or blue zinc-plated, blue zinc-plated $\geq 12\mu\text{m}$, bonus-zincd, burnished, nickel-/, brass plated

Nominal diameter		3,0	3,5	4,0	4,5	5,0	6,0									
d	Outer diameter	3,00	3,50	4,00	4,50	5,00	6,00									
	Allow. deviation	$\pm 0,30$														
d ₁	Core diameter	2,00	2,20	2,50	2,70	3,00	4,00									
	Allow. deviation	$-0,25 / +0,10$				$\pm 0,20$										
d _h	Head diameter	6,00	7,00	8,00	9,00	10,00	12,00									
	Allow. deviation	$-0,50 / +0,10$														
d _s	Shank diameter	2,25	2,60	2,90	3,25	3,60	4,20									
	Allow. deviation	$-0,30 / +0,10$														
h	Head height	1,90	2,10	2,50	2,70	3,00	3,80									
p	Thread pitch	1,50	1,80	2,00	2,20	2,50	3,00-4,50									
	Allow. deviation	$\pm 10\%$														
l _r ¹⁾	Shank ribs length	3,75	4,25	4,75	5,50	6,00	7,00									
	Allow. deviation	$\pm 0,75$				$\pm 1,00$										
Drive TX		10		20		20	25	30								
Drive PZ		1	2				3									
Screw length l _s		Standard thread length l _{gf} = Full thread l _{gp} = Partial thread Tolerance: $\pm 2,0$ ²⁾														
Nominal length	min	max	l _{gf}	l _{gp}	l _{gf}	l _{gp}	l _{gf}	l _{gp}	l _{gf}	l _{gp}	l _{gf}	l _{gp}	l _{gf}	l _{gp}		
20	18,95	21,05	16		16		16		16							
25	23,75	26,25	21		21	18	20	18	20							
30	28,75	31,25	26	18	26	18	25	18	25	18	24					
35	33,50	36,50	31	24	31	24	30	24	30	24	29	24	28			
40	38,50	41,50	36	24	36	24	35	24	35	24	34	24	33	24		
45	43,50	46,50	41	30	41	30	40	30	40	30	39	30	38	30		
50	48,50	51,50			46	30	45	30	45	30	44	30	43	30		
55	53,50	56,50					50	36	50	36	49	36	48			
60	58,50	61,50						36		36		36	53	36		
70	68,50	71,50						42		42		42	63	42		
80	78,50	81,50						50		50		50	73	50		
90	88,25	91,75										60		60		
100	98,25	101,75										60		60		
110	108,25	111,75										70		70		
120	118,25	121,75										70		70		
in steps of 10mm																
130-300	l _s -2,00	l _s +2,00														70

All sizes in mm

- Intermediate lengths at l_s are possible
- Screws with partial thread > 50 mm length with shank ribs
- Threaded lengths between $4 \times d \leq l_g \leq l_{gmax}$ are possible

²⁾ $10\text{mm} \geq l_g \leq 18\text{mm} \triangleq \pm 1,5\text{mm}$
 $18\text{mm} \geq l_g \leq 30\text{mm} \triangleq \pm 1,7\text{mm}$

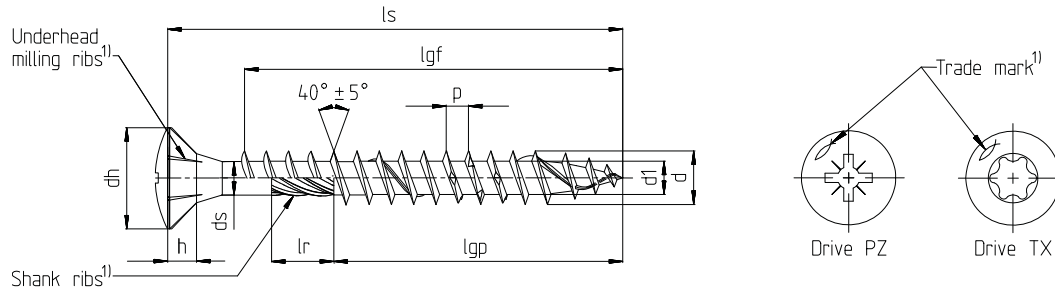

¹⁾ optional

Power-Fast self-drilling screw - Raised countersunk head with full- or partial thread

<ul style="list-style-type: none"> Carbon steel Possible surface treatments: yellow or blue-zinc-plated, blue zinc-plated $\geq 12\mu\text{m}$, bonus-zinc-plated, burnished, nickel-/brass plated 																
Nominal diameter		3,0	3,5	4,0	4,5	5,0	6,0									
d	Outer diameter	3,00	3,50	4,00	4,50	5,00	6,00									
	Allow. deviation	$\pm 0,30$														
d ₁	Core diameter	2,00	2,20	2,50	2,70	3,00	4,00									
	Allow. deviation	$-0,25 / +0,10$					$\pm 0,20$									
d _h	Head diameter	6,00	7,00	8,00	9,00	10,00	12,00									
	Allow. deviation	$-0,50 / +0,10$														
d _s	Shank diameter	2,25	2,60	2,90	3,25	3,60	4,20									
	Allow. deviation	$-0,30 / +0,10$														
h	Head height	1,90	2,10	2,50	2,70	3,00	3,40									
p	Thread pitch	1,50	1,80	2,00	2,20	2,50	3,00-4,50									
	Allow. deviation	$\pm 10\%$														
l _r ¹⁾	Shank ribs length	3,75	4,25	4,75	5,50	6,00	7,00									
	Allow. deviation	$\pm 0,75$					$\pm 1,00$									
Drive TX		10			20			20	25	30						
Drive PZ		1	2							3						
Screw length l _s		Standard thread length l _{gf} = Full thread l _{gp} = Partial thread Tolerance: $\pm 2,0$ ²⁾														
Nominal length	min	max	l _{gf}	l _{gp}	l _{gf}	l _{gp}	l _{gf}	l _{gp}	l _{gf}	l _{gp}	l _{gf}	l _{gp}	l _{gf}	l _{gp}		
20	18,95	21,05	16		16		16		16							
25	23,75	26,25	21		21	18	20	18	20							
30	28,75	31,25	26	18	26	18	25	18	25	18	24					
35	33,50	36,50	31	24	31	24	30	24	30	24	29	24	28			
40	38,50	41,50	36	24	36	24	35	24	35	24	34	24	33	24		
45	43,50	46,50	41	30	41	30	40	30	40	30	39	30	38	30		
50	48,50	51,50			46	30	45	30	45	30	44	30	43	30		
55	53,50	56,50					50	36	50	36	49	36	48			
60	58,50	61,50						36		36		36	53	36		
70	68,50	71,50						42		42		42	63	42		
80	78,50	81,50						50		50		50	73	50		

All sizes in mm

- Intermediate lengths at l_s are possible
- Screws with partial thread > 50 mm length with shank ribs ²⁾ 10mm $\geq l_g \leq 18\text{mm} \triangleq \pm 1,5\text{mm}$
- Threaded lengths between $4 \times d \leq l_g \leq l_{g\text{max}}$ are possible 18mm $\geq l_g \leq 30\text{mm} \triangleq \pm 1,7\text{mm}$

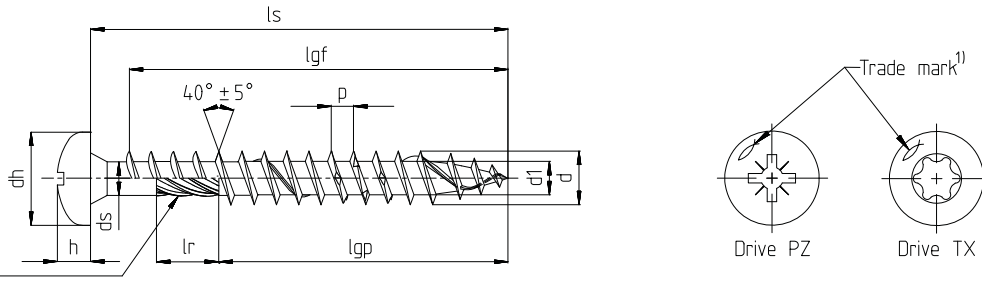

Shank ribs¹⁾
¹⁾ optional

Power-Fast self-drilling screw - Pan head with full- or partial thread

<ul style="list-style-type: none"> Carbon steel Possible surface treatments: yellow or blue zinc-plated, blue zinc-plated $\geq 12\mu\text{m}$, bonus- zined, burnished, nickel-/brass plated 																
Nominal diameter		3,0	3,5	4,0	4,5	5,0	6,0									
d	Outer diameter	3,00	3,50	4,00	4,50	5,00	6,00									
	Allow. deviation	$\pm 0,30$														
d _i	Core diameter	2,00	2,20	2,50	2,70	3,00	4,00									
	Allow. deviation	$-0,25 / +0,10$				$\pm 0,20$										
d _h	Head diameter	6,00	7,00	8,00	9,00	10,00	12,00									
	Allow. deviation	$-0,50 / +0,10$														
d _s	Shank diameter	2,25	2,60	2,90	3,25	3,60	4,20									
	Allow. deviation	$-0,30 / +0,10$														
h	Head height	2,30	2,50	2,90	3,10	3,40	3,80									
	Thread pitch	1,50	1,80	2,00	2,20	2,50	3,00-4,50									
p	Thread pitch	1,50	1,80	2,00	2,20	2,50	3,00-4,50									
	Allow. deviation	$\pm 10\%$														
l _r ¹⁾	Shank ribs length	3,75	4,25	4,75	5,50	6,00	7,00									
	Allow. deviation	$\pm 0,75$			$\pm 1,00$											
Drive TX		10		20		20	25									
Drive PZ		1	2			3										
Screw length l _s		Standard thread length l _{gf} = Full thread l _{gp} = Partial thread Tolerance: $\pm 2,0$ ²⁾														
Nominal length	min	max	l _{gf}	l _{gp}	l _{gf}	l _{gp}	l _{gf}	l _{gp}	l _{gf}	l _{gp}	l _{gf}	l _{gp}	l _{gf}	l _{gp}		
20	18,95	21,05	16		16		16		16							
25	23,75	26,25	21		21	18	20	18	20							
30	28,75	31,25	26	18	26	18	25	18	25	18	24					
35	33,50	36,50	31	24	31	24	30	24	30	24	29	24	28			
40	38,50	41,50		24	36	24	35	24	35	24	34	24	33	24		
45	43,50	46,50		30		30	40	30	40	30	39	30	38	30		
50	48,50	51,50				30	45	30	45	30	44	36	43	30		
55	53,50	56,50					50	36	50	36	49	36	48			
60	58,50	61,50						36		36		42	53	36		
70	68,50	71,50						42		42		50	63	42		
80	78,50	81,50						50		50		50	73	50		
90	88,25	91,75										60		60		
100	98,25	101,75										60		60		

All sizes in mm

- Intermediate lengths at l_s are possible
- Screws with partial thread > 50 mm length with shank ribs
- Threaded lengths between $4 \times d \leq l_g \leq l_{gmax}$ are possible

²⁾ $10\text{mm} \geq l_g \leq 18\text{mm} \triangleq \pm 1,5\text{mm}$
 $18\text{mm} \geq l_g \leq 30\text{mm} \triangleq \pm 1,7\text{mm}$

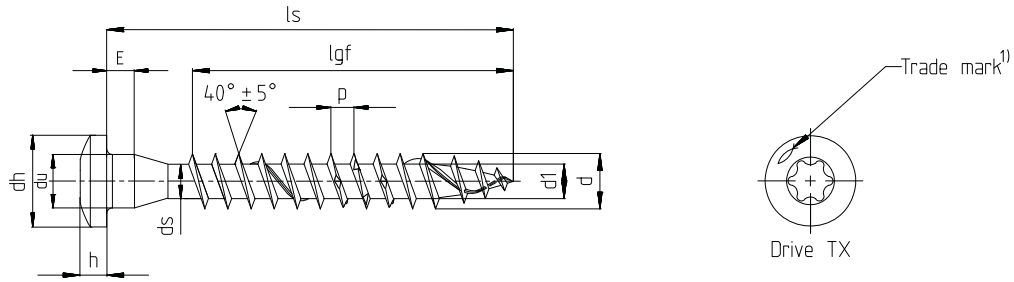

¹⁾ optional

Power-Fast self-drilling screw - Wood connector screw with full thread

<ul style="list-style-type: none"> Carbon steel Possible surface treatments: yellow or blue zinc-plated, Bonus-zinc, blue zinc-plated $\geq 12\mu\text{m}$ 																			
Nominal diameter		5,0																	
d	Outer diameter	5,00																	
	Allow. deviation	-0,30																	
d ₁	Core diameter	3,00																	
	Allow. deviation	$\pm 0,20$																	
d _u	Underhead diameter	5,00																	
	Allow. deviation	-0,35																	
d _h	Head diameter	8,25																	
	Allow. deviation	$\pm 0,40$																	
E	Height	2,50																	
	Allow. deviation	$\pm 0,30$																	
h	Head height	2,60																	
	Thread pitch	2,50																	
p	Thread pitch	2,50																	
	Allow. deviation	$\pm 10\%$																	
Drive TX		20 25																	
Screw length l _s			Standard thread length l _{gf} = Full thread l _{gp} = Partial thread Tolerance: $\pm 2,0^{2)}$																
Nominal length	min	max	l _{gf}	l _{gp}															
20	18,95	21,05	14																
25	23,75	26,25	19																
30	28,75	31,25	24																
35	33,50	36,50	29																
40	38,50	41,50	34																
45	43,50	46,50	39																
50	48,50	51,50	44																
55	53,50	56,50	49																
60	58,50	61,50	54																
70	68,50	71,50	64																
80	78,50	81,50	74																

All sizes in mm

- Intermediate lengths at l_s are possible
- Threaded lengths between $4 \times d \leq l_g \leq l_{gmax}$ are possible

²⁾ $10\text{mm} \geq l_g \leq 18\text{mm} \triangleq \pm 1,5\text{mm}$
 $18\text{mm} \geq l_g \leq 30\text{mm} \triangleq \pm 1,7\text{mm}$

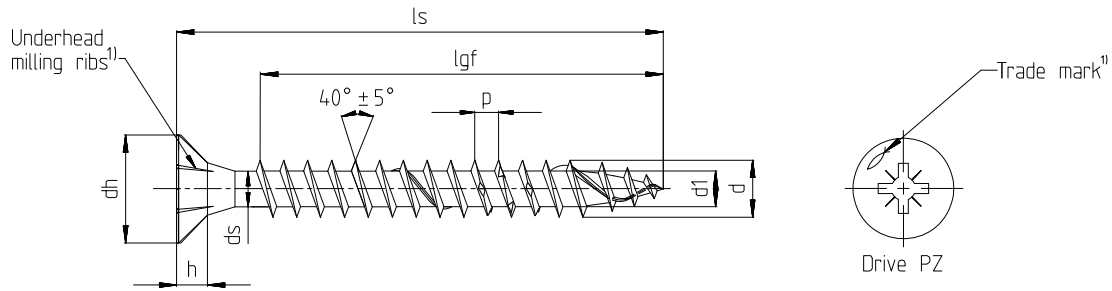

¹⁾ optional

Power-Fast self-drilling screw - Small countersunk head with full thread

<ul style="list-style-type: none"> Carbon steel Possible surface treatments: yellow or blue zinc-plated, blue zinc-plated $\geq 12\mu\text{m}$ 													
Nominal diameter		3,0	3,5	4,0									
d	Outer diameter	3,00	3,50	4,00									
	Allow. deviation	$\pm 0,30$											
d ₁	Core diameter	2,00	2,20	2,50									
	Allow. deviation	$-0,25 / +0,10$											
d _h	Head diameter	5,00	6,00	7,00									
	Allow. deviation	$-0,50 / +0,10$											
h	Head height	1,90	2,10	2,50									
p	Thread pitch	1,50	1,80	2,00									
	Allow. deviation	$\pm 10\%$											
Drive PZ		1	2										
Screw length l _s		Standard thread length l _{gf} = Full thread l _{gp} = Partial thread Tolerance: $\pm 2,0$ ²⁾											
Nominal length	min	max	l _{gf}	l _{gp}	l _{gf}	l _{gp}	l _{gf}	l _{gp}					
20	18,95	21,05	16		16		16						
25	23,75	26,25	21		21		20						
30	28,75	31,25	26										

All sizes in mm

- Intermediate lengths at l_s are possible
- Threaded lengths between $4 \times d \leq l_g \leq l_{g\text{max}}$ are possible

²⁾ $10\text{mm} \geq l_g \leq 18\text{mm} \triangleq \pm 1,5\text{mm}$
 $18\text{mm} \geq l_g \leq 30\text{mm} \triangleq \pm 1,7\text{mm}$

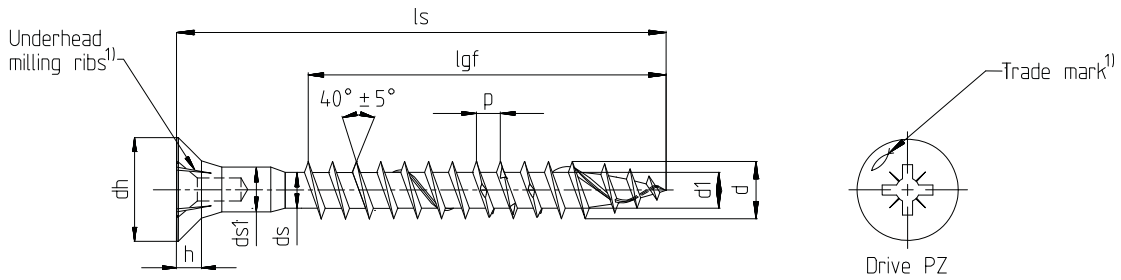

¹⁾ optional

Power-Fast self-drilling screw - Countersunk headhole screw with full thread

<ul style="list-style-type: none"> Carbon steel Possible surface treatments: blue zinc-plated, blue zinc-plated $\geq 12\mu\text{m}$ 																			
Nominal diameter		4,0	4,5	5,0	6,0														
d	Outer diameter	4,00	4,50	5,00	6,00														
	Allow. deviation	$\pm 0,30$																	
d ₁	Core diameter	2,50	2,70	3,00	4,00														
	Allow. deviation	$-0,25 / +0,10$		$\pm 0,20$															
d _h	Head diameter	8,00	9,00	10,00	12,00														
	Allow. deviation	$-0,50 / +0,10$																	
d _s	Shank diameter	2,90	3,25	3,60	4,30														
	Allow. deviation	$-0,30 / +0,10$																	
h	Head height	2,50	2,70	3,00	3,80														
p	Thread pitch	2,00	2,20	2,50	3,00-4,50														
	Allow. deviation	$\pm 10\%$																	
d _{s1}	Shank diameter	3,70	3,85	4,50	4,20														
	Allow. deviation	$-0,10$																	
Drive PZ		2			3														
Screw length l _s		Standard thread length l _{gf} = Full thread l _{gp} = Partial thread Tolerance: $\pm 2,0^{2)}$																	
Nominal length	min	max	l _{gf}	l _{gp}	l _{gf}	l _{gp}	l _{gf}	l _{gp}	l _{gf}	l _{gp}	l _{gf}	l _{gp}							
25	23,75	26,25	17,5																
27	25,75	28,25	19,5																
30	28,75	31,25	22,5		19														
35	33,50	36,50	27,5		24														
40	38,50	41,50	32,5		29		29												
45	43,50	46,50	37,5		34		34												
50	48,50	51,50	42,5		39		39		41										
55	53,50	56,50	47,5		44		44		46										
60	58,50	61,50	50,0		49		49		51										
70	68,50	71,50			59		60		60										
80	78,50	81,50			59		60		60										
90	88,25	91,75			59		60		60										
100	98,25	101,75					60		60										

All sizes in mm

- Intermediate lengths at l_s are possible
- Threaded lengths between $4 \times d \leq l_g \leq l_{gmax}$ are possible

²⁾ $10\text{mm} \geq l_g \leq 18\text{mm} \triangleq \pm 1,5\text{mm}$
 $18\text{mm} \geq l_g \leq 30\text{mm} \triangleq \pm 1,7\text{mm}$

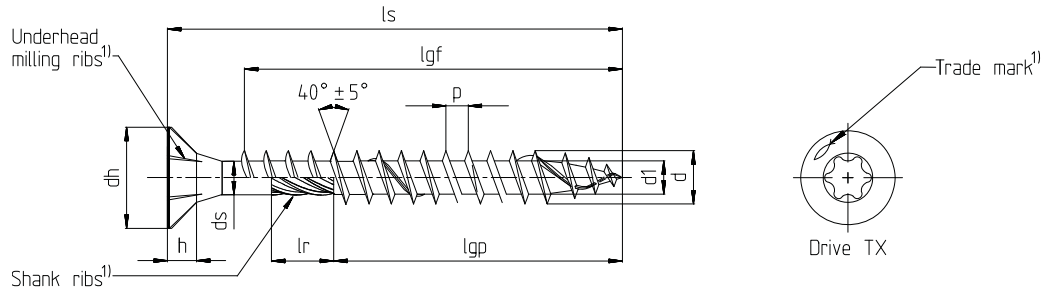

¹⁾ optional

Power-Fast wood construction screw - Countersunk head with full- or partial thread

<ul style="list-style-type: none"> Carbon steel Possible surface treatments: yellow or blue zinc-plated, blue zinc-plated $\geq 12\mu\text{m}$, bonus-zinc 																
Nominal diameter		6,0	8,0	10,0	12,0											
d	Outer diameter	6,00	8,00	10,00	12,00											
	Allow. deviation	$\pm 0,30$		$\pm 0,40$	$\pm 0,50$											
d _i	Core diameter	4,00	5,40	6,40	7,60											
	Allow. deviation	$\pm 0,20$		$\pm 0,30$												
d _h	Head diameter	12,00	14,40	18,40	22,40											
	Allow. deviation	-0,50 / +0,10	$\pm 0,40$		$\pm 0,50$											
d _s	Shank diameter	4,30	5,90	7,10	8,30											
	Allow. deviation	-0,30 / +0,10	$\pm 0,20$													
h	Head height	3,80	5,10	6,10	7,20											
	Thread pitch	3,00-4,50	6,00	7,50												
p	Allow. deviation	$\pm 10\%$														
	Shank ribs length	8,00	13,00													
l _r ¹⁾	Allow. deviation	-2,00														
	Drive TX	30	40		50											
Standard thread length l _{gf} = Full thread l _{gp} =Partial thread Tolerance: $\pm 2,0$																
Nominal length	min	max	l _{gf}	l _{gp}	l _{gf}	l _{gp}	l _{gf}	l _{gp}	l _{gf}	l _{gp}						
60	58,50	61,50	50	36												
80	78,50	81,50	70	50	70	50		52								
90	88,25	91,75		60	80	50										
100	98,25	101,75		60	80	50		52		60						
120	118,25	121,75		70	100	75		80		80						
140	138,00	142,00		70		75		80		80						
160	158,00	162,00		70		75		80		80						
180	178,00	182,00		70		75		100		100						
200	198,00	202,00		70		100		100		100						
220	218,00	222,00		70		100		100		100						
240	238,00	242,00		70		100		100		120						
260	258,00	262,00		70		100		100		120						
280	278,00	282,00		70		100		115		120						
300	298,00	302,00		70		100		115		120						
320	317,00	323,00				100		115								
330	327,00	333,00						115								
340	337,00	343,00				100		115								
350	347,00	353,00								145						
360	357,00	363,00				100		115								
380	377,00	383,00				100		115								
400	397,00	403,00														
450/500	l _s -3,00	l _s +3,00				100		115		145						
550/600	l _s -3,00	l _s +3,00								145						

All sizes in mm

- Intermediate lengths at l_s are possible
- Threaded lengths between $4 \times d \leq l_g \leq l_{gmax}$ are possible

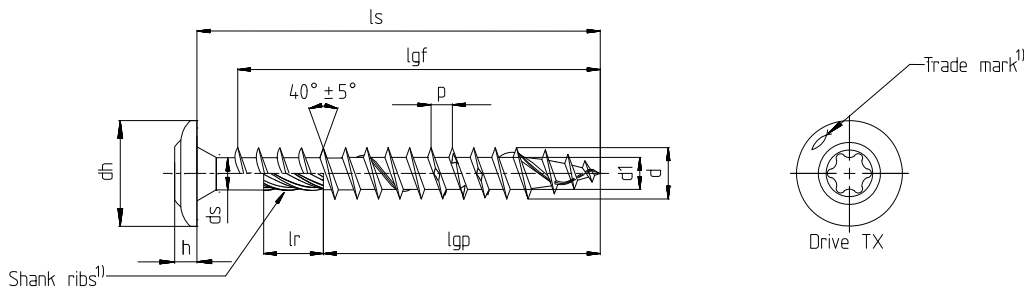

1) optional

Power-Fast wood construction screw - Flange head with full- or partial thread

<ul style="list-style-type: none"> Carbon steel Possible surface treatments: yellow or blue zinc-plated, blue zinc-plated $\geq 12\mu\text{m}$, bonus-zincd 																
Nominal diameter		6,0	8,0	10,0	12,0											
d	Outer diameter	6,00	8,00	10,00	12,00											
	Allow. deviation	$\pm 0,30$		$\pm 0,40$	$\pm 0,50$											
d ₁	Core diameter	4,00	5,40	6,40	7,60											
	Allow. deviation	$\pm 0,20$			$\pm 0,30$											
d _h	Head diameter	13,70	21,00	24,70	27,90											
	Allow. deviation	-0,70/+1,30	$\pm 1,00$	-1,20/+2,80	-1,40/+2,60											
d _s	Shank diameter	4,30	5,90	7,10	8,30											
	Allow. deviation	-0,30/+0,10	$\pm 0,20$		$\pm 0,30$											
h	Head height	3,50		5,60	6,70											
	Allow. deviation	$\pm 1,00$		$\pm 0,50$												
p	Thread pitch	3,00-4,50	6,00	7,50												
	Allow. deviation	$\pm 10\%$														
l _r ¹⁾	Shank rib length	8,00	13,00													
	Allow. deviation	-2,00														
Drive TX		30	40	50												
Screw length l _s		Standard thread length l _{gf} = Full thread l _{gp} =Partial thread Tolerance: $\pm 2,0$														
Nominal length	min	max	l _{gf}	l _{gp}	l _{gf}	l _{gp}	l _{gf}	l _{gp}	l _{gf}	l _{gp}						
60	58,50	61,50	50	36												
80	78,50	81,50	70	50	70	50		52								
90	88,25	91,75		60	80	50										
100	98,25	101,75		60	80	50		52		60						
120	118,25	121,75		70	100	75		80		80						
140	138,00	142,00		70		75		80		80						
160	158,00	162,00		70		75		80		80						
180	178,00	182,00		70		75		100		100						
200	198,00	202,00		70		100				100						
220	218,00	222,00		70		100		100		100						
240	238,00	242,00		70		100		100		100						
260	258,00	262,00		70		100		100		100						
280	278,00	282,00		70		100		115		120						
300	298,00	302,00		70		100		115		120						
320	317,00	323,00				100		115								
330	327,00	333,00						115								
340	337,00	343,00				100		115								
350	347,00	353,00								145						
in steps of 10mm																
360-500	l _s -3,00	l _s +3,00				100		115								
in steps of 50mm																
550-600	l _s -3,00	l _s +3,00								145						

All sizes in mm

- Intermediate lengths at l_s are possible
- Threaded lengths between $4 \times d \leq l_g \leq l_{gmax}$ are possible

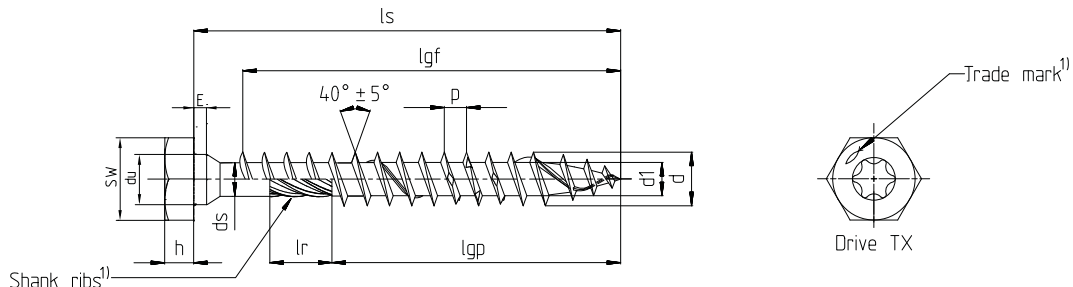

1) optional

Power-Fast wood construction screw - Hexagon head with full- or partial thread

<ul style="list-style-type: none"> Carbon steel Possible surface treatments: yellow or blue zinc-plated, blue zinc-plated $\geq 12\mu\text{m}$, bonus-zinc 																		
Nominal diameter		6,0	8,0	10,0	12,0													
d	Outer diameter	6,00	8,00	10,00	12,00													
	Allow. deviation	$\pm 0,30$		$\pm 0,40$	$\pm 0,50$													
di	Core diameter	4,00	5,40	6,40	7,60													
	Allow. deviation	$\pm 0,20$		$\pm 0,30$														
du	Underhead diameter	6,25	8,25	10,30	12,40													
	Allow. deviation	$-0,80$		$-0,90$	$-1,00$													
SW	Wrench size	9,90	12,80	14,80	16,80													
	Allow. deviation	$\pm 0,30$																
E	Height	2,00	2,10	2,30	3,30													
	Allow. deviation	$\pm 0,50$																
ds	Shank diameter	4,30	5,90	7,10	8,30													
	Allow. deviation	$-0,30/+0,10$		$\pm 0,20$														
h	Head height	4,00	4,50	5,20	5,70													
	Allow. deviation	$\pm 0,30$	$\pm 0,40$	$\pm 0,50$														
p	Thread pitch	3,00-4,50	6,00	7,50														
	Allow. deviation	$\pm 10\%$																
lr ¹⁾	Shank rib length	8,00		13,00														
	Allow. deviation	$-2,00$																
Drive TX		30	40	50														
Screw length ls			Standard thread length l _{gf} = Full thread l _{gp} =Partial thread Tolerance: $\pm 2,0^2)$															
Nominal length	min	max	l _{gf}	l _{gp}	l _{gf}	l _{gp}	l _{gf}	l _{gp}	l _{gf}	l _{gp}								
60	58,5	61,5	50	30														
80	78,5	81,5	70	50	70	50		52										
90	88,25	91,75		60	80	50												
100	98,25	101,75		60	80	50		52		60								
120	118,25	121,75		70	100	75		80		80								
140/160	l _s -2,00	l _s +2,00		70		75		80		80								
180	178,00	182,00		70		75		100		100								
200/220	l _s -2,00	l _s +2,00		70		100		100		100								
240/260	l _s -2,00	l _s +2,00		70		100		100		120								
280/300	l _s -2,00	l _s +2,00		70		100		115		120								
320	317,00	323,00				100		115										
330	327,00	333,00						115										
340	337,00	343,00				100		115										
350	347,00	353,00								145								
360/380	l _s -3,00	l _s +3,00				100		115										
in steps of 50mm																		
400-500	l _s -3,00	l _s +3,00				100		115		145								
550/600	l _s -3,00	l _s +3,00								145								

All sizes in mm

- Intermediate lengths at l_s are possible
- Threaded lengths between $4 \times d \leq l_g \leq l_{gmax}$ are possible

²⁾ $18\text{mm} \geq l_g \leq 30\text{mm} \hat{=} \pm 1,7\text{mm}$

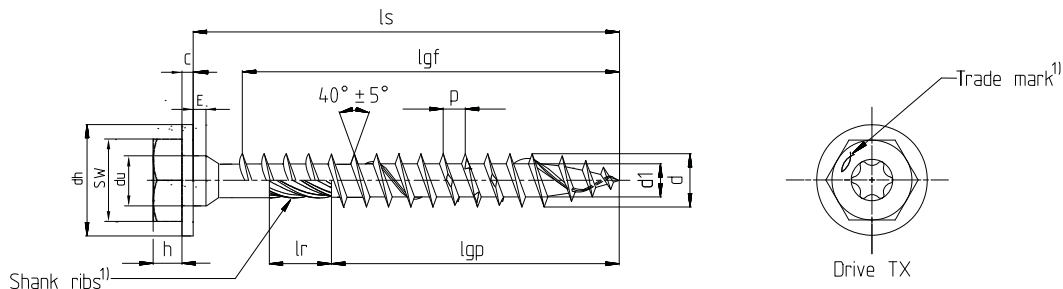

¹⁾ optional

Power-Fast wood construction screw - Hexagon head with washer and full- or partial thread

<ul style="list-style-type: none"> Carbon steel Possible surface treatments: yellow or blue zinc-plated, blue zinc-plated $\geq 12\mu\text{m}$, bonus-zincd 																
Nominal diameter		6,0	8,0	10,0	12,0											
d	Outer diameter	6,00	8,00	10,00	12,00											
	Allow. deviation	$\pm 0,30$		$\pm 0,40$	$\pm 0,50$											
d _i	Core diameter	4,00	5,40	6,40	7,60											
	Allow. deviation	$\pm 0,20$			$\pm 0,30$											
d _h	Head diameter	15,00	18,00	21,50	23,40											
	Allow. deviation	1,20			1,50											
d _u	Underhead diameter	6,25	8,25	10,30	12,40											
	Allow. deviation	-0,80		-0,90	-1,00											
SW	Wrench size	9,90	12,80	14,80	16,80											
	Allow. deviation	$\pm 0,30$														
c	Washer height	1,80	2,00	2,20	2,50											
E	Height	2,00	2,10	2,30	3,30											
	Allow. deviation	$\pm 0,50$														
d _s	Shank diameter	4,30	5,90	7,10	8,30											
	Allow. deviation	-0,30/+0,10		$\pm 0,20$												
h	Head height	4,00	4,50	5,20	5,70											
	Allow. deviation	$\pm 0,30$	$\pm 0,40$	$\pm 0,50$												
p	Thread pitch	3,00-4,50	6,00	7,50												
	Allow. deviation	$\pm 10\%$														
l _r ¹⁾	Shank rib length	8,00		13,00												
	Allow. deviation	-2,00														
Drive TX		30	40	50												
Screw length l _s		Standard thread length l _{gf} = Full thread l _{gp} =Partial thread Tolerance: $\pm 2,0$ ²⁾														
Nominal length	min	max	l _{gf}	l _{gp}	l _{gf}	l _{gp}	l _{gf}	l _{gp}	l _{gf}	l _{gp}						
60	58,50	61,50	50	30												
80	78,50	81,50	70	50	70	50		52								
90	88,25	91,75		60	80	50										
100	98,25	101,75		60	80	50		52		60						
120	118,25	121,75		70	100	75		80		80						
140/160	l _s -2,00	l _s +2,00		70		75		80		80						
180	178,00	182,00		70		75		100		100						
200/220	l _s -2,00	l _s +2,00		70		100		100		100						
240/260	l _s -2,00	l _s +2,00		70		100		100		120						
280/300	l _s -2,00	l _s +2,00		70		100		115		120						
320	317,00	323,00				100		115								
330	327,00	333,00						115								
340	337,00	343,00				100		115								
350	347,00	353,00								145						
360/380	l _s -3,00	l _s +3,00				100		115								
in steps of 50mm																
400-500	l _s -3,00	l _s +3,00				100		115		145						
550/600	l _s -3,00	l _s +3,00								145						

All sizes in mm

- Intermediate lengths at l_s are possible
- Threaded lengths between $4 \times d \leq l_g \leq l_{gmax}$ are possible

²⁾ $18\text{mm} \geq l_g \leq 30\text{mm} \triangleq \pm 1,7\text{mm}$

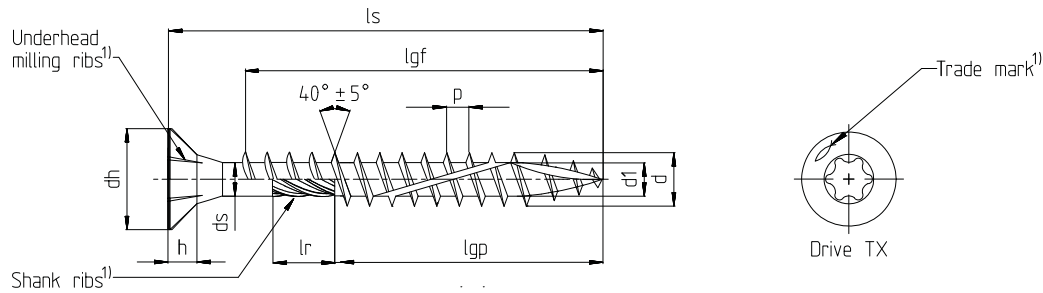

¹⁾ optional

FCS wood construction screw - Countersunk head with full- or partial thread

<ul style="list-style-type: none"> Carbon steel Possible surface treatments: yellow or blue zinc-plated, blue zinc-plated $\geq 12\mu\text{m}$, bonus-zincd 															
Nominal diameter		8,0	10,0												
d	Outer diameter	8,00	10,00												
	Allow. deviation	$\pm 0,30$	$\pm 0,40$												
d ₁	Core diameter	5,40	6,35												
	Allow. deviation	$-0,30/+0,20$													
d _h	Head diameter	14,40	18,40												
	Allow. deviation	$\pm 0,40$													
d _s	Shank diameter	5,90	7,10												
	Allow. deviation	$-0,30/+0,10$													
h	Head height	6,00-7,00	7,50-8,50												
	Thread pitch	5,20	5,60												
p	Allow. deviation	$\pm 10\%$													
	Shank rib length	13,0													
l _r ¹⁾	Allow. deviation	$-2,00$													
	Drive TX	40													
Screw length l _s		Standard thread length l _{gf} = Full thread l _{gp} =Partial thread Tolerance: $\pm 2,0$													
Nominal length	min	max	l _{gf}	l _{gp}	l _{gf}	l _{gp}									
80	78,50	81,50	70	50		52									
90	88,25	91,75	80	50		52									
100	98,25	101,75	80	50		52									
110	108,25	111,75	100	75		80									
120	118,25	121,75		75		80									
in steps of 10mm															
130-400	l _s -2,00	l _s +2,00		75		80									

All sizes in mm

- Intermediate lengths at l_s are possible
- Threaded lengths between $4 \times d \leq l_g \leq l_{gmax}$ are possible

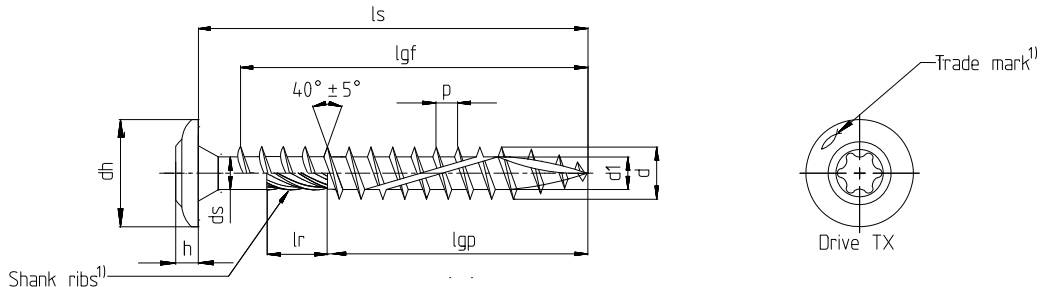

1) optional

FCS wood construction screw - Flange head with partial thread

<ul style="list-style-type: none"> Carbon steel Possible surface treatments: yellow or blue zinc-plated, blue zinc-plated $\geq 12\mu\text{m}$ 																		
Nominal diameter		8,0	10,0															
d	Outer diameter	8,00	10,00															
	Allow. deviation	-0,40/+0,30	$\pm 0,40$															
d ₁	Core diameter	5,40	6,35															
	Allow. deviation	$\pm 0,30$																
d _h	Head diameter	21,00	24,70															
	Allow. deviation	$\pm 1,00$	-1,20/+2,80															
d _s	Shank diameter	5,90	7,10															
	Allow. deviation	-0,30/+0,20																
h	Head height	2,50-4,50	3,70-5,70															
	Thread pitch	5,20	5,60															
p	Allow. deviation	$\pm 10\%$																
	Shank rib length	12,00																
l _r ¹⁾	Allow. deviation	$\pm 1,00$																
	Drive TX	40																
Screw length l _s		Standard thread length l _{gf} = Full thread l _{gp} = Partial thread Tolerance: $\pm 2,0$																
Nominal length	min	max	l _{gf}	l _{gp}	l _{gf}	l _{gp}												
80	78,50	81,50	70	50		52												
90	88,25	91,75	80	50		52												
100	98,25	101,75	80	50		52												
110	108,25	111,75	100	75		80												
120	118,25	121,75		75		80												
in steps pf 10mm																		
130-400	l _s -2,00	l _s +2,00		75		80												

All sizes in mm

- Intermediate lengths at l_s are possible
- Threaded lengths between $4 \times d \leq l_g \leq l_{gmax}$ are possible

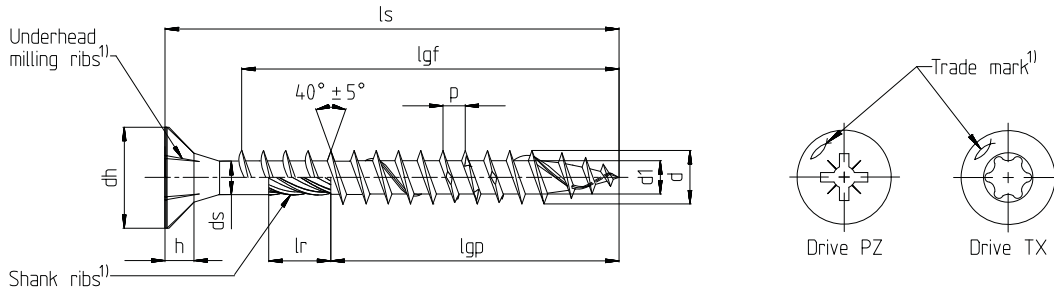

1) optional

Power-Fast self-drilling screw - Countersunk head with full- or partial thread

▪ Stainless steel																
Nominal diameter		3,0	3,5	4,0	4,5	5,0	6,0									
d	Outer diameter	3,00	3,50	4,00	4,50	5,00	6,00									
	Allow. deviation	±0,30														
d ₁	Core diameter	2,00	2,20	2,50	2,70	3,00	4,00									
	Allow. deviation	-0,25 / +0,10					±0,20									
d _h	Head diameter	6,00	7,00	8,00	9,00	10,00	12,00									
	Allow. deviation	-0,50 / +0,10														
d _s	Shank diameter	2,25	2,60	2,90	3,25	3,60	4,30									
	Allow. deviation	-0,30 / +0,10														
h	Head height	1,90	2,10	2,50	2,70	3,00	3,80									
	Thread pitch	1,50	1,80	2,00	2,20	2,50	3,00-4,50									
p	Allow. deviation	±10%														
	Shank rib length	3,75	4,25	4,75	5,50	6,00	7,00									
l _r ¹⁾	Allow. deviation	±0,75					±1,00									
	Drive TX	10			20			20	25	30						
Drive PZ	1	2								3						
Screw length l _s		Standard thread length l _{gf} = Full- thread l _{gp} =Partial thread Tolerance: ± 2,0 ²⁾														
Nominal length	min	max	l _{gf}	l _{gp}	l _{gf}	l _{gp}	l _{gf}	l _{gp}	l _{gf}	l _{gp}	l _{gf}	l _{gp}	l _{gf}	l _{gp}		
20	18,95	21,05	16		16		16		16							
25	23,75	26,25	21		21	18	20	18	20							
30	28,75	31,25	26	18	26	18	25	18	25	18	24					
35	33,50	36,50	31	24	31	24	30	24	30	24	29	24	28			
40	38,50	41,50	36	24	36	24	35	24	35	24	34	24	33	24		
45	43,50	46,50	41	30	41	30	40	30	40	30	39	30	38	30		
50	48,50	51,50			46	30	45	30	45	30	44	30	43	30		
55	53,50	56,50					50	36	50	36	49	36	48			
60	58,50	61,50						36		36		36	53	36		
70	68,50	71,50						42		42		42	63	42		
80	78,50	81,50						50		50		50	73	50		
90	88,25	91,75										60		60		
100	98,25	101,75										60		60		
110	108,25	111,75										70		70		
120	118,25	121,75										70		70		
in steps of 10mm																
130-300	l _s -2,00	l _s +2,00														70

All sizes in mm

- Intermediate lengths at l_s are possible
 - Screws with partial thread > 50 mm length with shank ribs
 - Threaded lengths between 4×d ≤ l_g ≤ l_{gmax} are possible
- 2) 10mm ≥ l_g ≤ 18mm ≙ ±1,5mm
18mm ≥ l_g ≤ 30mm ≙ ±1,7mm

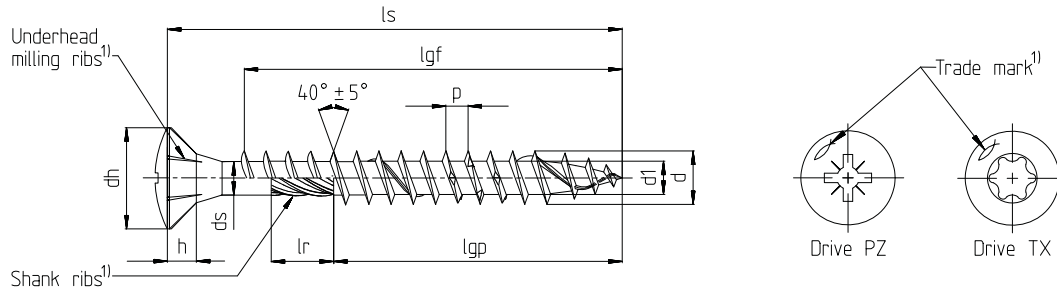

1) optional

Power-Fast self-drilling screw - Raised countersunk head with full- or partial thread

▪ Stainless steel																
Nominal diameter		3,0	3,5	4,0	4,5	5,0	6,0									
d	Outer diameter	3,00	3,50	4,00	4,50	5,00	6,00									
	Allow. deviation	±0,30														
d ₁	Core diameter	2,00	2,20	2,50	2,70	3,00	4,00									
	Allow. deviation	-0,25 / +0,10					±0,20									
d _h	Head diameter	6,00	7,00	8,00	9,00	10,00	12,00									
	Allow. deviation	-0,50 / +0,10														
d _s	Shank diameter	2,25	2,60	2,90	3,25	3,60	4,30									
	Allow. deviation	-0,30 / +0,10														
h	Head height	1,90	2,10	2,50	2,70	3,00	3,80									
p	Thread pitch	1,50	1,80	2,00	2,20	2,50	3,00-4,50									
	Allow. deviation	±10%														
l _r ¹⁾	Shank ribs length	3,75	4,25	4,75	5,50	6,00	7,00									
	Allow. deviation	±0,75					±1,00									
Drive TX		10			20			20	25	30						
Drive PZ		1	2				3									
Screw length l _s		Standard thread length l _{gf} = Full thread l _{gp} = Partial thread Tolerance: ± 2,0 ²⁾														
Nominal length	min	max	l _{gf}	l _{gp}	l _{gf}	l _{gp}	l _{gf}	l _{gp}	l _{gf}	l _{gp}	l _{gf}	l _{gp}	l _{gf}	l _{gp}		
20	18,95	21,05	16		16		16		16							
25	23,75	26,25	21		21	18	21	18	20							
30	28,75	31,25	26	18	26	18	26	18	25	18	24					
35	33,50	36,50	31	24	31	24	31	24	30	24	29	24	28			
40	38,50	41,50		24	36	24	36	24	35	24	34	24	33			
45	43,50	46,50		30		30	41	30	40	30	39	30	38			
50	48,50	51,50			30	46	30	45	30	44	30	43				
55	53,50	56,50						36		36		36				
60	58,50	61,50						36		36		36	53			
70	68,50	71,50						42		42		42	63			
80	78,50	81,50						50		50		50	73			

All sizes in mm

- Intermediate lengths at l_s are possible
- Screws with partial thread > 50 mm length with shank ribs
- Threaded lengths between 4×d ≤ l_g ≤ l_{gmax} are possible

2) 10mm ≥ l_g ≤ 18mm ≅ ±1,5mm
18mm ≥ l_g ≤ 30mm ≅ ±1,7mm

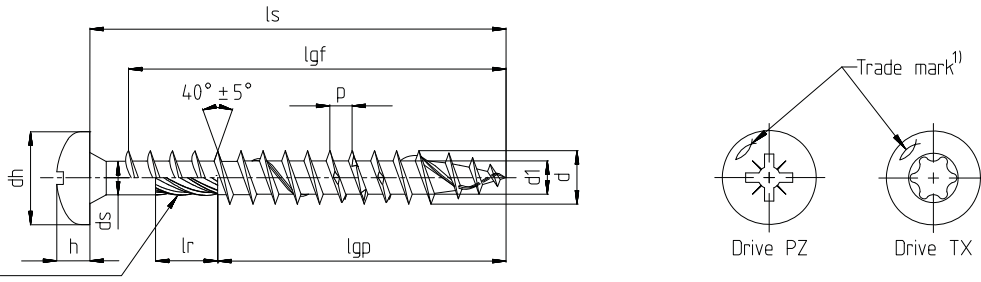

1) optional

Power-Fast self-drilling screw - Pan head with full- or partial thread

▪ Stainless steel																
Nominal diameter		3,0	3,5	4,0	4,5	5,0	6,0									
d	Outer diameter	3,00	3,50	4,00	4,50	5,00	6,00									
	Allow. deviation	±0,30														
d ₁	Core diameter	2,00	2,20	2,50	2,70	3,00	4,00									
	Allow. deviation	-0,25 / +0,10					±0,20									
d _h	Head diameter	6,00	7,00	8,00	9,00	10,00	12,00									
	Allow. deviation	-0,50 / +0,10														
d _s	Shank diameter	2,25	2,60	2,90	3,25	3,60	4,30									
	Allow. deviation	-0,30 / +0,10														
h	Head height	2,30	2,50	2,90	3,10	3,40	3,80									
p	Thread pitch	1,50	1,80	2,00	2,20	2,50	3,00-4,50									
	Allow. deviation	±10%														
l _r ¹⁾	Shank ribs length	3,75	4,25	4,75	5,50	6,00	7,00									
	Allow. deviation	±0,75					±1,00									
Drive TX		10			20			20	25	30						
Drive PZ		1	2				3									
Screw length l _s			Standard thread length l _{gf} = Full thread l _{gp} =Partial thread Tolerance: ± 2,0 ²⁾													
Nominal length	min	max	l _{gf}	l _{gp}	l _{gf}	l _{gp}	l _{gf}	l _{gp}	l _{gf}	l _{gp}	l _{gf}	l _{gp}	l _{gf}	l _{gp}		
20	18,95	21,05	16		16		16									
25	23,75	26,25	21		21	18	20	18	20							
30	28,75	31,25	26	18	26	18	25	18	25	18	24					
35	33,50	36,50	31	24	31	24	30	24	30	24	29	24	28			
40	38,50	41,50		24	36	24	35	24	35	24	34	24	33	24		
45	43,50	46,50		30		30	40	30	40	30	39	30	38	30		
50	48,50	51,50				30	45	30	45	30	44	36	43	30		
55	53,50	56,50					50	36	50	36	49	36	48			
60	58,50	61,50						36		36		42	53	36		
70	68,50	71,50						42		42		50	63	42		
80	78,50	81,50						50		50		50	73	50		
90	88,25	91,75										60		60		
100	98,25	101,75										60		60		

All sizes in mm

- Intermediate lengths at l_s are possible
- Screws with partial thread > 50 mm length with shank ribs
- Threaded lengths between 4×d ≤ l_g ≤ l_{gmax} are possible

2) 10mm ≥ l_g ≤ 18mm ≅ ±1,5mm
18mm ≥ l_g ≤ 30mm ≅ ±1,7mm

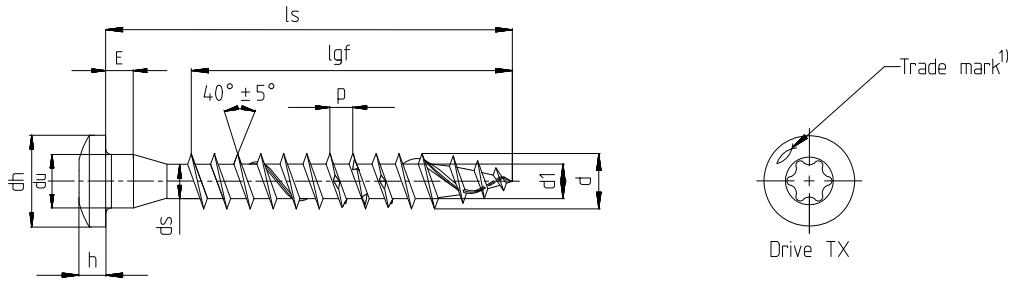

1) optional

Power-Fast self-drilling screw - Wood connector screw with full thread

<ul style="list-style-type: none"> Stainless steel 												
Nominal diameter		5,0										
d	Outer diameter	5,00										
	Allow. deviation	-0,30										
d ₁	Core diameter	3,00										
	Allow. deviation	±0,20										
d _u	Underhead diameter	5,00										
	Allow. deviation	-0,35										
d _h	Head diameter	8,25										
	Allow. deviation	±0,40										
E	Height	2,50										
	Allow. deviation	±0,30										
h	Head height	2,60										
p	Thread pitch	2,50										
	Allow. deviation	±10%										
Drive TX		20	25									
Screw length l _s				Standard thread length l _{gf} = Full thread l _{gp} =Partial thread Tolerance: ± 2,0 ²⁾								
Nominal length	min	max	l _{gf}	l _{gp}								
20	18,95	21,05	14									
25	23,75	26,25	19									
30	28,75	31,25	24									
35	33,50	36,50	29									
40	38,50	41,50	34									
45	43,50	46,50	39									
50	48,50	51,50	44									
55	53,50	56,50	49									
60	58,50	61,50	54									
70	68,50	71,50	64									
80	78,50	81,50	74									

All sizes in mm

- Intermediate lengths at l_s are possible
- Threaded lengths between 4×d ≤ l_g ≤ l_{gmax} are possible

2) 10mm ≥ l_g ≤ 18mm ≅ ±1,5mm
18mm ≥ l_g ≤ 30mm ≅ ±1,7mm

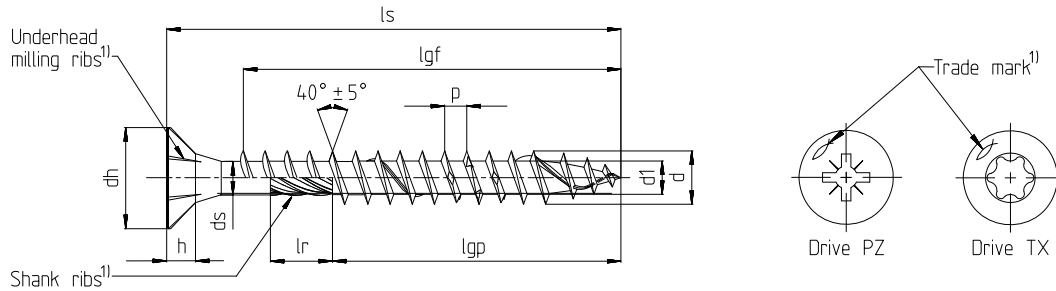

1) optional

Power-Fast wood construction screw - Countersunk head with full- or partial thread

▪ Stainless steel												
Nominal diameter		6,0	8,0									
d	Outer diameter	6,00	8,00									
	Allow. deviation	±0,30										
d ₁	Core diameter	4,00	5,40									
	Allow. deviation	±0,20										
d _h	Head diameter	12,00	14,40									
	Allow. deviation	-0,50/+0,10	±0,40									
d _s	Shank diameter	4,30	5,90									
	Allow. deviation	-0,30/+0,10	±0,20									
h	Head height	3,80	5,10									
	Thread pitch	3,00-4,50	6,00									
p	Allow. deviation	±10%										
	Shank rib length	7,00	13,00									
l _r ¹⁾	Allow. deviation	±1,00	-2,00									
	Drive TX	30	40									
Drive PZ		3	-									
Screw length l _s				Standard thread length l _{gf} = Full thread l _{gp} = Partial thread Tolerance: ± 2,0								
Nominal length	min	max		l _{gf}	l _{gp}	l _{gf}	l _{gp}					
60	58,50	61,50		50	36							
80	78,50	81,50		70	50	70	50					
90	88,25	91,75			60	80	50					
100	98,25	101,75			60	80	50					
120	118,25	121,75			70	100	75					
140	138,00	142,00			70		75					
160	158,00	162,00			70		75					
180	178,00	182,00			70		75					
in steps of 20mm												
200-300	l _s -2,00	l _s +2,00			70		100					
in steps of 20mm												
320-500	l _s -3,00	l _s +3,00					100					

All sizes in mm

- Intermediate lengths at l_s are possible
- Screws with partial thread > 50 mm length with shank ribs
- Threaded lengths between 4×d ≤ l_g ≤ l_{gmax} are possible

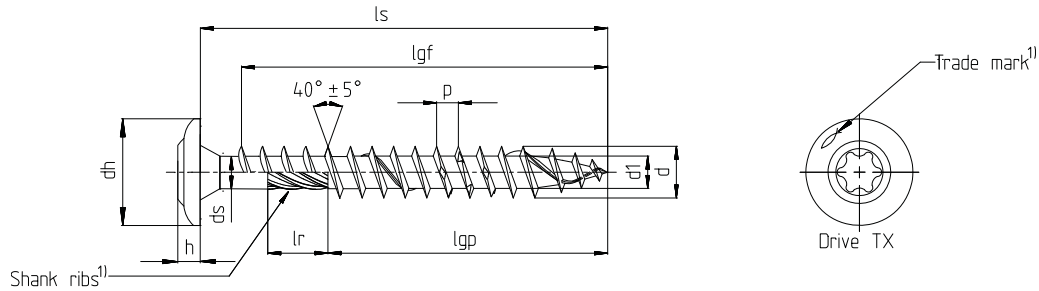

1) optional

Power-Fast wood construction screw - Flange head with full- or partial thread

<ul style="list-style-type: none"> Stainless steel 												
Nominal diameter		6,0		8,0								
d	Outer diameter	6,00		8,00								
	Allow. deviation	±0,30										
d ₁	Core diameter	4,00		5,40								
	Allow. deviation	-0,30/+0,20										
d _h	Head diameter	13,70		21,00								
	Allow. deviation	-0,70/+1,30		±1,00								
d _s	Shank diameter	4,30		5,90								
	Allow. deviation	-0,30/+0,10										
h	Head height	3,50										
	Allow. deviation	±1,00										
p	Thread pitch	3,00-4,50		6,00								
	Allow. deviation	±10%										
l _r ¹⁾	Shank rib length	8,00		13,00								
	Allow. deviation	-2,00										
Drive TX		30		40								
Screw length l _s			Standard thread length l _{gf} = Full thread l _{gp} =Partial thread Tolerance: ± 2,0									
Nominal length	min	max	l _{gf}	l _{gp}	l _{gf}	l _{gp}						
60	58,50	61,50	50	36								
80	78,50	81,50	70	50	70	50						
90	88,25	91,75		60	80	50						
100	98,25	101,75		60	80	50						
120	118,25	121,75		70	100	75						
140	138,00	142,00		70		75						
160	158,00	162,00		70		75						
180	178,00	182,00		70		75						
in steps of 20mm												
200-300	l _s -2,00	l _s +2,00		70		100						
in steps of 20mm												
320-500	l _s -3,00	l _s +3,00				100						

All sizes in mm

- Intermediate lengths at l_s are possible
- Threaded lengths between 4×d ≤ l_g ≤ l_{gmax} are possible

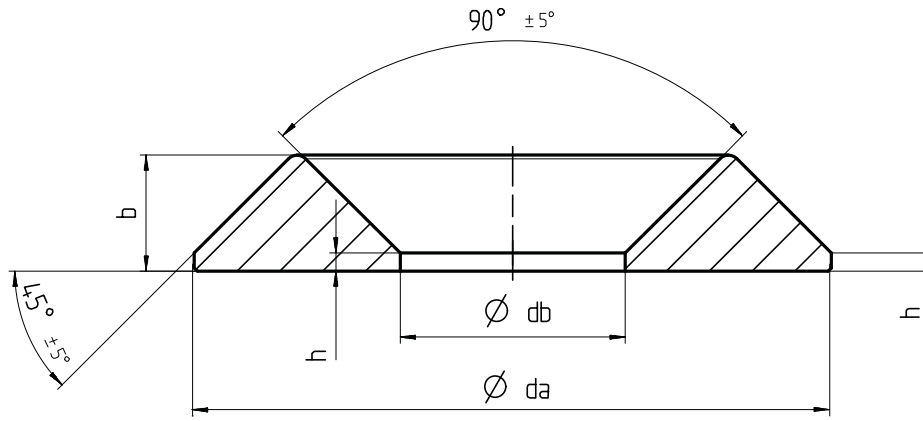

Washer for Power-Fast and construction screws

<ul style="list-style-type: none"> ▪ Carbon Steel - possible surface treatments: yellow or blue zinc-plated, bonus- zined, $\geq 12\mu\text{m}$ blue zinc-plated ▪ Stainless steel 								
Nominal diameter		Type 1				Type 2		
Size		6	8	10	12	6	8	10
db	Inner diameter	6,70	8,70	11,20	6,70	6,70	8,70	11,20
	Allow. deviation	-0,40						
da	Outer diameter	21	30	35	43	21	25,50	30,50
	Allow. deviation	$\pm 2,0$						
b	Height	4,70	5,20	6,20	8,30	4,70	5,20	6,20
	Allow. deviation	-0,40						
h	Height	1,50	1,80	2,00	2,20	1,50	1,80	2,00
	Allow. deviation	-0,15						

All sizes in mm

Annex B
Fixing of on-roof insulation system

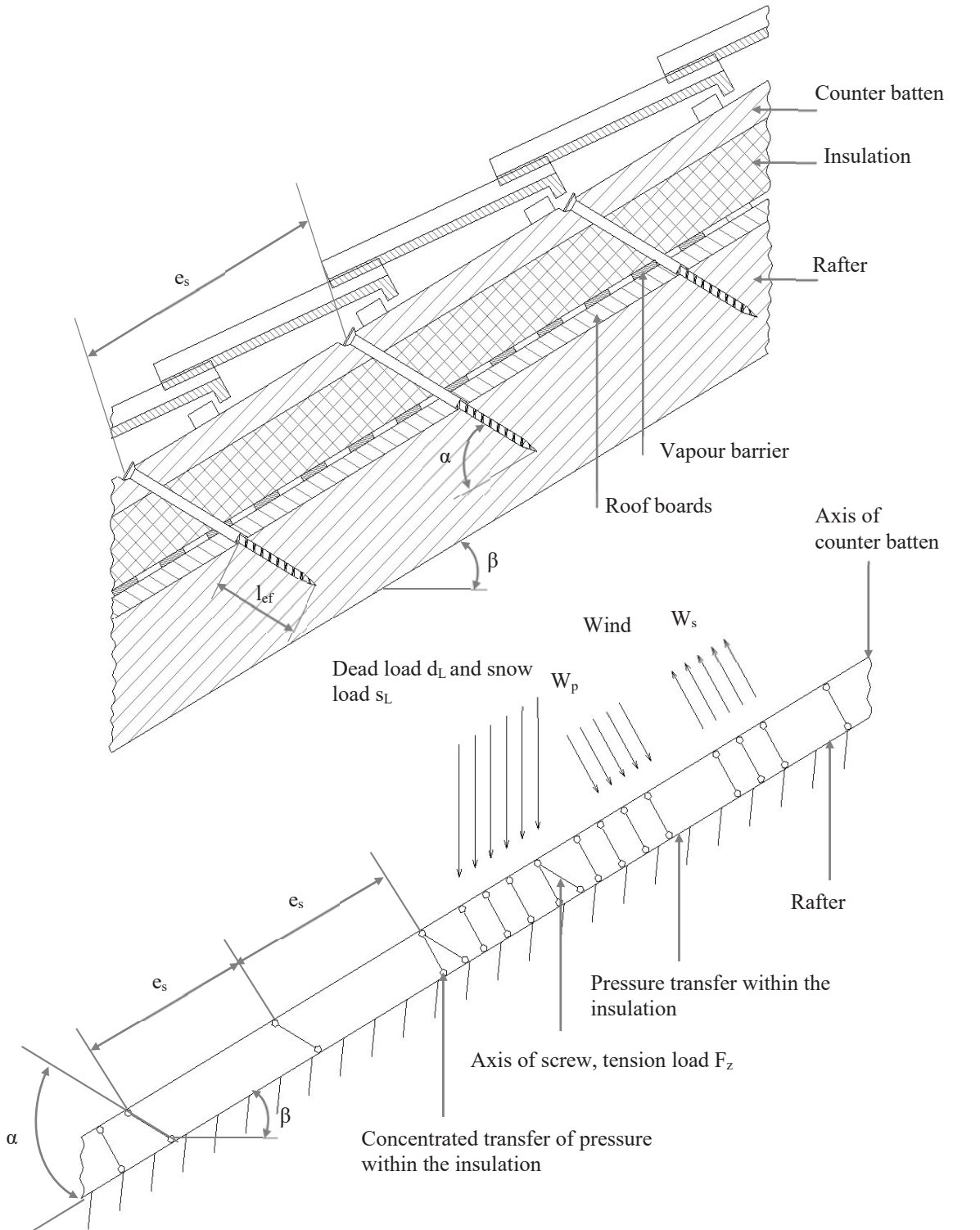

- | | | | | | |
|---------|---|-------------------|----------|---|--|
| W_s | = | Wind suction | W_p | = | Wind pressure |
| e_s | = | Spacing of screws | l_{ef} | = | Thread part part of screw in rafter |
| β | = | Roof inclination | α | = | Angle between axis of screw and axis of rafter |

Design of the battens

The bending stresses are calculated as:

$$M = \frac{(F_b + F_s) \cdot \ell_{\text{char}}}{4}$$

Where

$$\ell_{\text{char}} = \text{characteristic length } \ell_{\text{char}} = \sqrt[4]{\frac{4 \cdot EI}{w_{\text{ef}} \cdot K}}$$

EI = bending stiffness of the batten

K = coefficient of subgrade

w_{ef} = effective width of the heat insulation

F_b = Point loads perpendicular to the battens

F_s = Point loads perpendicular to the battens, load application in the area of the screw heads

The coefficient of subgrade K may be calculated from the modulus of elasticity E_{HI} and the thickness t_{HI} of the heat insulation if the effective width w_{ef} of the heat insulation under compression is known. Due to the load extension in the heat insulation the effective width w_{ef} is greater than the width of the batten or rafter, respectively. For further calculations, the effective width w_{ef} of the heat insulation may be determined according to:

$$w_{\text{ef}} = w + t_{\text{HI}} / 2$$

where

w = minimum width of the batten or rafter, respectively

t_{HI} = thickness of the heat insulation

$$K = \frac{E_{\text{HI}}}{t_{\text{HI}}}$$

The following condition shall be satisfied:

$$\frac{\sigma_{\text{m,d}}}{f_{\text{m,d}}} = \frac{M_{\text{d}}}{W \cdot f_{\text{m,d}}} \leq 1$$

For the calculation of the section modulus W the net cross section has to be considered.

The shear stresses shall be calculated according to:

$$V = \frac{(F_b + F_s)}{2}$$

The following condition shall be satisfied:

$$\frac{\tau_{\text{d}}}{f_{\text{v,d}}} = \frac{1,5 \cdot V_{\text{d}}}{A \cdot f_{\text{v,d}}} \leq 1$$

For the calculation of the cross section area the net cross section has to be considered.

Design of the heat insulation

The compressive stresses in the heat insulation shall be calculated according to:

$$\sigma = \frac{1,5 \cdot F_b + F_s}{2 \cdot \ell_{\text{char}} \cdot w}$$

The design value of the compressive stress shall not be greater than 110 % of the compressive stress at 10 % deformation calculated according to EN 826.

Design of the screws

The screws are loaded predominantly axially. The axial tension force in the screw may be calculated from

the shear loads of the roof R_s :

$$T_s = \frac{R_s}{\cos \alpha}$$

The load-carrying capacity of axially loaded screws is the minimum design value of the axial withdrawal capacity of the threaded part of the screw, the head pull-through capacity of the screw and the tensile capacity of the screw.

In order to limit the deformation of the screw head for heat insulation thicknesses over 200 mm or with compressive strength below 0,12 N/mm², respectively, the axial withdrawal capacity of the screws shall be reduced by the factors k_1 and k_2 :

$$F_{ax,\alpha,Rd} = \min \begin{cases} k_{ax} * f_{ax,d} * d * l_{ef} * k_1 * k_2 * \left(\frac{\rho_k}{350}\right)^{0,8} \\ f_{head,d} * d_h^2 * \left(\frac{\rho_k}{350}\right)^{0,8} \\ f_{tens,d} \end{cases} \quad [N]$$

where:

$f_{ax,d}$	design value of the axial withdrawal parameter of the threaded part of the screw
d	outer thread diameter of the screw
l_{ef}	Point side penetration length of the threaded part of the screw in the rafter, $l_{ef} \geq 40$ mm
α	Angle between grain and screw axis ($\alpha \geq 30^\circ$)
ρ_k	characteristic density of the wood-based member [kg/m ³]
$f_{head,d}$	design value of the head pull-through capacity of the screw
d_h	head diameter
k_1	$\min \{1; 200/t_{HI}\}$
k_2	$\min \{1; \sigma_{10\%}/0,12\}$
t_{HI}	thickness of the heat insulation [mm]
$\sigma_{10\%}$	compressive stress of the heat insulation under 10 % deformation [N/mm ²]
$f_{tens,d}$	Design value of the tensile capacity of the screw [N]

If equation k_1 and k_2 are considered, the deflection of the battens does not need to be considered. Alternatively to the battens, panels with a minimum thickness of 20 mm from plywood according to EN 636 or an ETA or national provisions that apply at the installation site, particle board according to EN 312 or an ETA or national provisions that apply at the installation site, oriented strand board according to EN 300 or an ETA or national provisions that apply at the installation site and solid wood panels according to EN 13353 or an ETA or national provisions that apply at the installation site or cross laminated timber according to an ETA may be used.

Thermal insulation material on rafters with parallel screws perpendicular to the roof plane

Alternatively to the battens, panels with a minimum thickness of 20 mm from plywood according to EN 636, particleboard according to EN 312, oriented strand board OSB/3 and OSB/4 according to EN 300 or European Technical Approval and solid wood panels according to EN 13353 may be used.

Characteristic load-carrying capacity of a screw loaded in shear:

$$F_{v,Rk} = \min \left\{ \begin{array}{l} f_{h,b,k} \cdot d \cdot t_b \\ f_{h,r,k} \cdot d \cdot t_r \\ \frac{f_{h,b,k} \cdot d \cdot \beta}{1 + \beta} \cdot \left(\sqrt{4t_{il}^2 + (2 + \frac{1}{\beta})t_b^2 + (2 + \beta)t_r^2 + 4t_{il}(t_b + t_r) + 2t_b t_r - 2t_{il} - t_b - t_r} \right) + \frac{F_{ax,Rk}}{4} \\ 1,05 \cdot \frac{f_{h,b,k} \cdot d \cdot \beta}{\frac{1}{2} + \beta} \left(\sqrt{t_{il}^2 + t_{il}t_b + \frac{t_b^2}{2} \left(1 + \frac{1}{\beta} \right) + \frac{M_{y,k}}{f_{h,b,k}d} \left(1 + \frac{2}{\beta} \right)} - t_{il} - \frac{t_b}{2} \right) + \frac{F_{ax,Rk}}{4} \\ 1,05 \cdot \frac{f_{h,b,k} \cdot d \cdot \beta}{\frac{1}{2} + \beta} \left(\sqrt{t_{il}^2 + t_{il}t_r + \frac{t_r^2}{2} (1 + \beta) + \frac{M_{y,k}}{f_{h,b,k}d} \left(2 + \frac{1}{\beta} \right)} - t_{il} - \frac{t_r}{2} \right) + \frac{F_{ax,Rk}}{4} \\ 1,15 \cdot \frac{f_{h,b,k} \cdot d}{1 + \beta} \left(\sqrt{\beta^2 t_{il}^2 + 4\beta(\beta + 1) \cdot \frac{M_{y,k}}{f_{h,b,k}d}} - \beta t_{il} \right) + \frac{F_{ax,Rk}}{4} \end{array} \right.$$

Where:

$f_{h,b,k}$	Characteristic batten embedding strength [N/mm ²]
$f_{h,r,k}$	Characteristic rafter embedding strength [N/mm ²]
β	$f_{h,r,k}/f_{h,b,k}$
d	Outer thread diameter [mm]
t_b	Batten thickness [mm]
t_r	The lower value of rafter thickness or screw penetration length [mm]
t_{il}	Interlayer thickness [mm]
$M_{y,k}$	Characteristic fastener yield moment [Nmm]
$F_{ax,Rk}$	Characteristic axial tensile capacity of the screw [N]

Annex C
Minimum distances and spacing

Axially or laterally loaded screws in the plane or edge surface of cross laminated timber

Definition of spacing, end and edge distances in the plane surface unless otherwise specified in the technical specification (ETA or hEN) for the cross laminated timber:

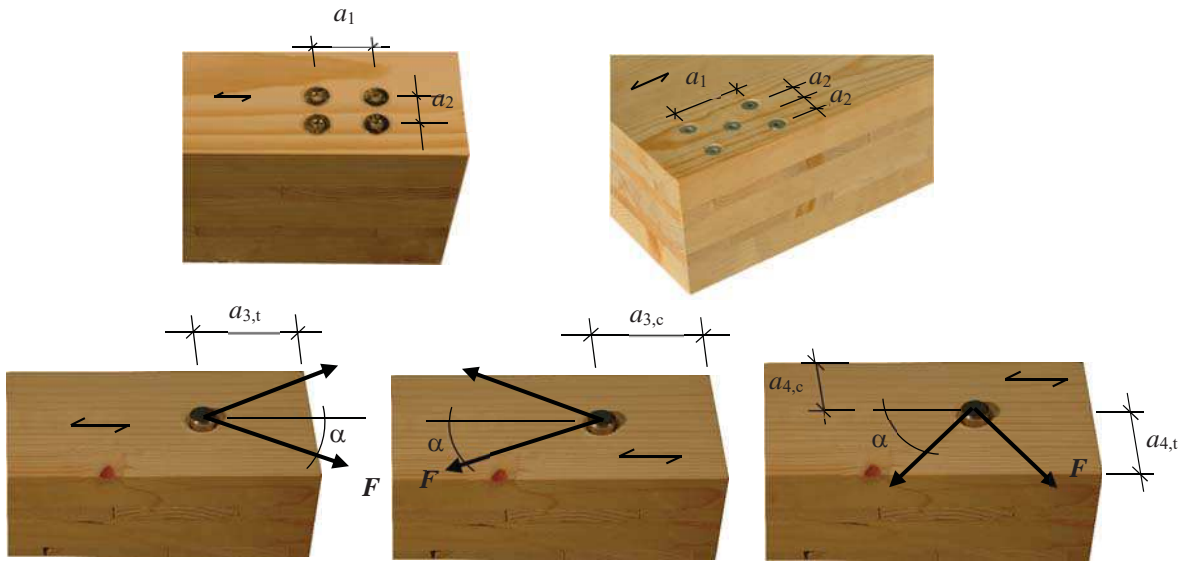

Definition of spacing, end and edge distances in the edge surface unless otherwise specified in the technical specification (ETA or hEN) for the cross laminated timber.

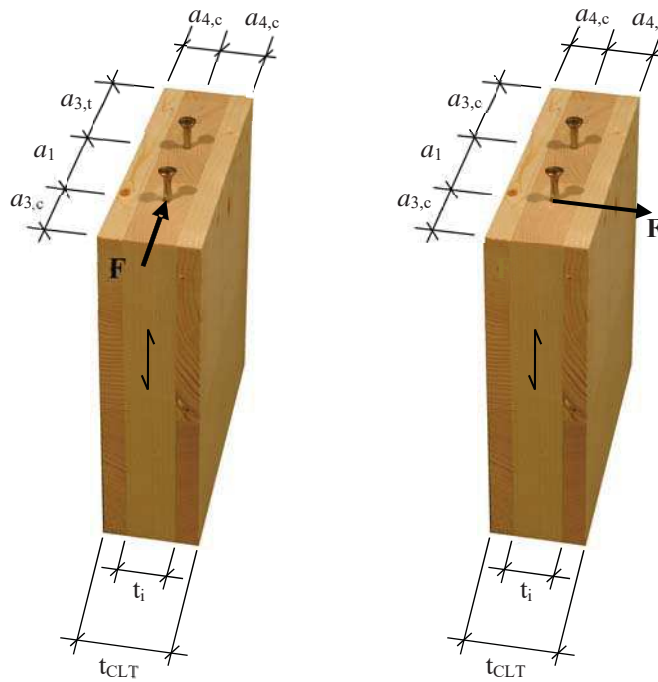

Table C1: Minimum spacing, end and edge distances of screws in the plane or edge surfaces of cross laminated timber

	a_1	$a_{3,t}$	$a_{3,c}$	a_2	$a_{4,t}$	$a_{4,c}$
Plane surface (see Figure 1)	$4 \cdot d$	$6 \cdot d$	$6 \cdot d$	$2,5 \cdot d$	$6 \cdot d$	$2,5 \cdot d$
Edge surface (see Figure 2)	$10 \cdot d$	$12 \cdot d$	$7 \cdot d$	$4 \cdot d$	$6 \cdot d$	$3 \cdot d$

LEISTUNGSERKLÄRUNG

DoP Nr. 0756-CPD-0382 - DE

1. Eindeutiger Kenncode des Produkttyps:

fischer Power-Fast Schrauben

2. Typen-, Chargen- oder Seriennummer oder ein anderes Kennzeichen zur Identifikation des Bauprodukts gemäß Artikel 11 Absatz 4:

ETA-11/0027, Anhang A1 – A14

3. Vom Hersteller vorgesehener Verwendungszweck oder vorgesehene Verwendungszwecke des Bauprodukts gemäß der anwendbaren harmonisierten technischen Spezifikation:

Gattung	Selbstschneidende Schrauben
zur Verwendung in	Holzkonstruktionen
Belastung	Statisch und quasi-statisch
Material	verzinkter Stahl:
	Nur in trockenen Innenräumen.
	Größen: Power-Fast 3,0 / 3,5 / 4,0 / 4,5 / 5,0 / 6,0 / 8,0 / 10,0 / 12,0
	Nichtrostender Stahl
	In trockenen Innenräumen als auch im Freien ohne besonders aggressive Bedingungen
	Größen: Power-Fast 3,0 / 3,5 / 4,0 / 4,5 / 5,0 / 6,0 / 8,0

4. Name, eingetragener Handelsname oder eingetragene Marke und Kontaktanschrift des Herstellers gemäß Artikel 11 Absatz 5:

fischerwerke GmbH & Co. KG, Weinhalde 14 - 18, 72178 Waldachtal, Deutschland

5. Gegebenenfalls Name und Kontaktanschrift des Bevollmächtigten, der mit den Aufgaben gemäß Artikel 12 Absatz 2 beauftragt ist: ---

6. System oder Systeme zur Bewertung und Überprüfung der Leistungsbeständigkeit des Bauprodukts gemäß Anhang V: **2+**

7. Im Falle der Leistungserklärung, die ein Bauprodukt betrifft, das von einer harmonisierten Norm erfasst wird: ---

8. Im Falle der Leistungserklärung, die ein Bauprodukt betrifft, für das eine Europäische Technische Bewertung ausgestellt worden ist:

**ETA-Danmark A/S hat Folgendes ausgestellt: ETA-11/0027
 auf der Grundlage von CUAP, ETA-11/0027.**

MPA Darmstadt 0756-CPD hat

- i) Erstinspektion des Werks und der werkseigenen Produktionskontrolle;
- ii) laufende Überwachung, Bewertung und Evaluierung der werkseigenen Produktionskontrolle.

nach dem System **2+** vorgenommen und Folgendes ausgestellt: Leistungsbeständigkeitsbescheinigung **0756-CPD-0382**.

9. Erklärte Leistung

Wesentliche Merkmale	Bemessungsmethode	Leistung	Harmonisierte technische Spezifikation
charakteristische Zugtragfähigkeit	ETA-11/0027, Annex B	ETA-11/0027, ETA-11/0027, Seite 5	CUAP, ETA-11/0027
charakteristische Quertragfähigkeit	ETA-11/0027, Annex B	ETA-11/0027, ETA-11/0027, Seite 7	
minimaler Achs- und Randabstand	ETA-11/0027, Annex B	ETA-11/0027, ETA-11/0027, Seite 12, Seite 13, Anhang C	

10. Die Leistung des Produkts gemäß den Nummern 1 und 2 entspricht der erklärten Leistung nach Nummer 9.

Verantwortlich für die Erstellung dieser Leistungserklärung ist allein der Hersteller gemäß Nummer 4.

Unterzeichnet für den Hersteller und im Namen des Herstellers von:

i. V. W. Hengesbach

Wolfgang Hengesbach
 Dipl.-Ing., Dipl.-Wirtsch.-Ing.
 Zulassungen & Technische Dokumente

i. V. A. Bucher

Andreas Bucher
 Dipl.-Ing.
 Forschung & Technologietransfer



Waldachtal, 2013-06-17

ETA-Dänemark A/S
Kollegievej 6
DK-2920 Charlottenlund
Tel. +45 72 24 59 00
Fax +45 72 24 59 04
Internet www.etadanmark.dk



MITGLIED DER EOTA

Genehmigt und gemeldet gemäß Artikel 10 der Richtlinie des Rates 89/106/EEC vom 21. Dezember 1988 zur Angleichung der Gesetze, Verordnungen und Verwaltungsvorschriften der Mitgliedsstaaten, die sich auf Bauprodukte beziehen

Übersetzung aus dem Englischen

Europäische Technische Zulassung ETA-11/0027

Diese ETA ersetzt die vorherige ETA mit derselben Nummer gültig von 2012-05-08 bis 2016-03-22

Handelsbezeichnung

Trade name

fischer Power-Fast Schrauben und fischer Holzbauschrauben FCS

fischer Power-Fast screws and fischer construction screws FCS

Zulassungsinhaber

Holder of approval

fischerwerke GmbH & Co. KG

Weinhalde 14 – 18

D-72178 Waldachtal

Tel. +49 7443 12-4000

Fax + +49 7443 12-4568

Internet www.fischer.de

Zulassungsgegenstand und Verwendungszweck

Generic type and use of construction product

fischer Power-Fast und fischer Holzbauschrauben FCS als Holzverbindungsmittel

Self-tapping screws for use in timber structures

Geltungsdauer

Validity

vom:
from

2013-06-26

bis:
to

2018-06-26

Herstellwerke

Manufacturing plants

fischerwerke

Diese Europäische Technische Zulassung enthält

This approval contains

35 Seiten einschließlich 3 Anhänge

35 pages including 3 annexes



European Organisation for Technical Approvals

Europæisk Organisation for Tekniske Godkendelser

I RECHTLICHE GRUNDLAGEN UND ALLGEMEINE BEDINGUNGEN

1 Diese Europäische Technische Zulassung wird erteilt durch ETA-Dänemark A/S gemäß:

- der Richtlinie des Rates 89/106/EEC vom 21. Dezember 1988 zur Angleichung der Gesetze, Verordnungen und Verwaltungsvorschriften der Mitgliedsstaaten, die sich auf Bauprodukte¹⁾ beziehen, in der durch Richtlinie des Rates 93/68/EEC vom 22. Juli 1993²⁾ geänderten Fassung.

- Rechtsverordnung 559 vom 27. Juni 1994 (ersetzt Rechtsverordnung 480 vom 25. Juni 1991) über das Inkrafttreten der Richtlinie des Rates vom 21. Dezember 1988 zur Angleichung der Rechts- und Verwaltungsvorschriften der Mitgliedsstaaten über Bauprodukte.

- den gemeinsamen Verfahrensregeln zur Beantragung, Vorbereitung und Erteilung von Europäischen Technischen Zulassungen gemäß Anhang zur Kommissionsentscheidung 94/23/EC³⁾.

2 ETA-Dänemark A/S ist berechtigt, die Einhaltung der Bestimmungen dieser Europäischen Technischen Zulassung zu prüfen. Die Prüfung kann in der Fertigungsstätte stattfinden. Gleichwohl bleibt der Inhaber der Europäischen Technischen Zulassung für die Konformität der Produkte mit der Europäischen Technischen Zulassung und ihre Eignung für die bestimmungsgemäße Verwendung verantwortlich.

3 Diese Europäische Technische Zulassung ist auf andere als die auf Seite 1 angegebenen Hersteller oder Beauftragte des Herstellers, bzw. andere Fertigungsstätten als die auf Seite 1 dieser Europäischen Technischen Zulassung genannten nicht übertragbar.

4 Diese Europäische Technische Zulassung kann von ETA-Dänemark A/S gemäß Artikel 5(1) der Richtlinie des Rates 89/106/EEC widerrufen werden.

1) Amtsblatt der Europäischen Gemeinschaft Nr. L40, 11. Februar 1989, Seite 12.

2) Amtsblatt der Europäischen Gemeinschaft Nr. L220, 30. August 1993, Seite 1.

3) Amtsblatt der Europäischen Gemeinschaft Nr. L 17, 20. Januar 1994, Seite 34.

5 Diese Europäische Technische Zulassung darf – auch bei Übermittlung in elektronischer Form – nur ungekürzt wiedergegeben werden. Mit schriftlicher Zustimmung der ETA-Dänemark A/S kann jedoch eine auszugsweise Wiedergabe erfolgen. In diesem Fall ist die auszugsweise Wiedergabe als solche zu kennzeichnen. Texte und Zeichnungen von Werbebroschüren dürfen weder im Widerspruch zur Europäischen Technischen Zulassung stehen noch diese missbräuchlich verwenden.

6 Diese Europäische Technische Zulassung wird durch ETA-Dänemark A/S in englischer Sprache erteilt. Diese Ausgabe entspricht in vollem Umfang der innerhalb der EOTA verteilten Fassung. Übersetzungen in andere Sprachen müssen als solche kenntlich gemacht werden.

II BESONDERE BEDINGUNGEN DER EUROPÄISCHEN TECHNISCHEN ZULASSUNG

1 Beschreibung des Produkts und des Verwendungszwecks

„fischer Power-Fast“-Schrauben und „fischer Holzbauschrauben FCS“ sind selbstbohrende Schrauben, die in Holzkonstruktionen verwendet werden. „fischer Power-Fast“-Schrauben haben ein Teilgewinde oder ein Vollgewinde, „fischer Holzbauschrauben FCS“ ein Teilgewinde. Aus Kohlenstoffstahl-Draht gefertigte Schrauben werden mit einem Nenndurchmesser von 3,0 mm bis 12,0 mm, Schrauben aus rostfreiem Stahldraht mit einem Nenndurchmesser von 3,0 mm bis 8,0 mm hergestellt. Die Materialspezifikation der Edelstahlschrauben ist bei der ETA-Danmark hinterlegt. Ist Korrosionsschutz erforderlich, so muss das Material bzw. die Beschichtung mit den in Anhang A der EN 14592 angeführten relevanten Spezifikationen übereinstimmen.

Geometrie und Material

Der Nenndurchmesser (Gewindeaußendurchmesser), d , darf nicht kleiner als 3,0 mm und nicht größer als 12,0 mm sein. Die Gesamtlänge der Schrauben, l_s , darf nicht kürzer als 20 mm und nicht länger als 600 mm sein. Die sonstigen Maße sind in Anhang A1 bis Anhang A14 angegeben.

Das Verhältnis des Kerndurchmessers zum äußeren Gewindedurchmesser, d_i/d , reicht von 0,59 bis 0,69.

Die Schrauben haben eine Mindestgewindelänge l_g von $4,0 \cdot d$ (i.e. $l_g \geq 4,0 \cdot d$).

Der mittlere Abstand p (Abstand zwischen zwei angrenzenden Gewindegängen) reicht von $0,50 \cdot d$ bis $0,67 \cdot d$.

Bis zu einem Biegewinkel α von $(45/d^{0,7} + 20)$ Grad dürfen keine Risse auftreten.

Die Materialspezifikation der Edelstahlschrauben ist bei der ETA-Danmark hinterlegt.

Verwendungszweck

Die Schrauben sind für die Verwendung in tragenden Holzkonstruktionen zur Verbindung von Teilen aus Vollholz (Nadelholz), Brettschichtholz, Brettsperrholz, Furnierschichtholz, ähnlichen verleimten Holzbauteilen, Holzwerkstoffplatten oder von Stahlteilen bestimmt.

Zudem können „fischer Power-Fast“-Schrauben mit einem Durchmesser von 6 mm, 8 mm, 10 mm und 12 mm auch zur Befestigung von Aufdachdämmsystemen auf Sparren

und zur Befestigung von Wärmedämmung an vertikalen Fassaden verwendet werden.

Stahlplatten und Holzwerkstoffplatten dürfen, mit Ausnahme von Vollholzplatten und Brettsperrholzplatten, nur schraubenkopfseitig angebracht werden. Die nachstehenden Holzwerkstoffe können verwendet werden:

- Sperrholz gemäß EN 636 oder Europäischer Technischer Zulassung
- Spanplatten gemäß EN 312 oder Europäischer Technischer Zulassung
- Grobspanplatten des Typs OSB/3 und OSB/4 gemäß EN 300 oder Europäischer Technischer Zulassung
- Faserplatten gemäß EN 622-2 und 622-3 oder Europäischer Technischer Zulassung (Mindestrohddichte 650 kg/m^3)
- Zementgebundene Spanplatten gemäß Europäischer Technischer Zulassung
- Vollholzplatten gemäß EN 13353 und EN 13986, sowie Brettsperrholz gemäß Europäischer Technischer Zulassung
- Furnierschichtholz gemäß EN 14374 oder Europäischer Technischer Zulassung
- Verarbeitete Holzwerkstoff-Produkte gemäß Europäischer Technischer Zulassung wenn diese Regelungen für die Verwendung von selbstbohrenden Schrauben enthält und die Vorgaben auch eingehalten sind.

Die Schrauben dürfen in Holz mit oder ohne Vorbohren eingedreht werden, wobei der Bohrdurchmesser der Vorbohrung über die gesamte Länge des Gewindebereichs nicht größer als der Kerndurchmesser und im Bereich des glatten Schafts nicht größer als der Schaftdurchmesser sein darf.

Die Schrauben sind für Holzverbindungen vorgesehen, welche die Anforderungen an mechanische Beständigkeit, Stabilität und Nutzungssicherheit im Sinne der grundlegenden Anforderungen 1 und 4 der Richtlinie 89/106/EWG des Rates erfüllen.

Form und Maße der Unterlegscheiben sind in Anhang A14 vorgegeben. Die Unterlegscheiben müssen aus Stahl sein.

Die Bemessung der Verbindungen muss auf den charakteristischen Tragfähigkeiten der Schrauben basieren. Die Tragfähigkeiten sind von den charakteristischen Werten gemäß Eurocode 5 oder einer entsprechenden nationalen Norm abzuleiten (z. B. DIN 1052:2008-12). Hinsichtlich der Umweltbedingungen finden die auf der Baustelle geltenden, nationalen Rechtsvorschriften Anwendung.

Die Schrauben sind für die Verwendung in Verbindungen mit ruhender oder vorwiegend ruhender Belastung vorgesehen.

Zinkbeschichtete Schrauben sind für die Verwendung in Holzkonstruktionen unter trockenen Innenraumbedingungen bzw. bei überdachten Außenkonstruktionen wie in den Nutzungsklassen 1 und 2 der EN 1995-1-1:2008 (Eurocode 5) definiert, vorgesehen.

Aus Edelstahl gefertigte Schrauben erfüllen die Anforderungen des Eurocode 5 (EN 1995-1-1:2008) für die Verwendung in Konstruktionen, die gemäß Definition in Nutzungsklasse 3 direkter Bewitterung ausgesetzt sind.

Erwartete Nutzungsdauer

Unter der Voraussetzung einer angemessenen Verwendung und Instandhaltung beträgt die vorgesehene Nutzungsdauer der Schrauben 50 Jahre.

Die Information zur Nutzungsdauer ist nicht als eine Garantie des Herstellers oder der die ETA ausstellenden Zulassungsstelle anzusehen. Die Bezeichnung „erwartete vorgesehene Nutzungsdauer“ bedeutet, dass bei normaler Nutzung nach Ablauf des Zeitraums der erwarteten Nutzungsdauer die tatsächliche Nutzungsdauer weitaus höher sein kann, sofern die grundlegenden Anforderungen nicht durch starke Schäden beeinträchtigt werden.

2 Produktmerkmale und Beurteilung

Merkmal	Beurteilung des Merkmals
2.1 Mechanische Beständigkeit und Stabilität*)	
2.1.1 Zugtragfähigkeit	Charakteristischer Wert $f_{\text{tens,k}}$: Schraube d = 3,0 mm: 2,7 kN Schraube d = 3,5 mm: 3,7 kN Schraube d = 4,0 mm: 4,8 kN Schraube d = 4,5 mm: 6,0 kN Schraube d = 5,0 mm: 7,5 kN Schraube d = 6,0 mm: 10,7 kN Schraube d = 8,0 mm: 19,1 kN Schraube d = 10,0 mm: 29,8 kN Schraube d = 12,0 mm: 32,7 kN Schrauben aus Edelstahl: Schraube d = 3,0 mm: 1,6 kN Schraube d = 3,5 mm: 2,1 kN Schraube d = 4,0 mm: 2,8 kN Schraube d = 4,5 mm: 3,5 kN Schraube d = 5,0 mm: 4,3 kN Schraube d = 6,0 mm: 6,2 kN Schraube d = 8,0 mm: 13,0 kN
2.1.2 Einschraubmoment	Verhältnis des charakteristischen Werts der Torsionsfestigkeit zum mittleren Einschraubmoment: $f_{\text{tor,k}} / R_{\text{tor,mean}} \geq 1,5$
2.1.3 Torsionsfestigkeit	Charakteristischer Wert $f_{\text{tor,k}}$: Schrauben aus Kohlenstoffstahl: Schraube d = 3,0 mm: 1,3 Nm Schraube d = 3,5 mm: 2,0 Nm Schraube d = 4,0 mm: 3,5 Nm Schraube d = 4,5 mm: 5,0 Nm Schraube d = 5,0 mm: 6,5 Nm Schraube d = 6,0 mm: 9,5 Nm Schraube d = 8,0 mm: 25,0 Nm Schraube d = 10,0 mm: 40,0 Nm Schraube d = 12,0 mm: 55,0 Nm Schrauben aus Edelstahl: Schraube d = 3,0 mm: 0,9 Nm Schraube d = 3,5 mm: 1,3 Nm Schraube d = 4,0 mm: 1,9 Nm Schraube d = 4,5 mm: 2,6 Nm Schraube d = 5,0 mm: 3,7 Nm Schraube d = 6,0 mm: 6,5 Nm Schraube d = 8,0 mm: 20,0 Nm

Merkmal	Beurteilung des Merkmals
2.2 Sicherheit im Brandfall	
2.2.1 Brandverhalten	Die Schrauben bestehen aus Stahl der Euroklasse A1 gemäß EN 1350-1 und EU-Beschluss 96/603/EC, geändert durch EU-Beschluss 2000/605/EC.
2.3 Hygiene, Gesundheit und Umwelt	
2.3.1 Beeinflussung der Luftqualität	Keine gefährlichen Materialien (**)
2.4 Gebrauchssicherheit	Nicht zutreffend
2.5 Lärmschutz	Nicht zutreffend
2.6 Energiewirtschaftlichkeit und Wärmespeicherung	Nicht zutreffend
2.7 Weitere Aspekte der Gebrauchstauglichkeit	
2.7.1 Haltbarkeit	Die Schrauben weisen bei der Verwendung in Holzkonstruktionen, in denen Holztypen gemäß Eurocode 5 und den Vorgaben der Nutzungsklassen 1 und 2 zum Einsatz kommen, eine zufriedenstellende Haltbarkeit und Gebrauchstauglichkeit auf.
2.7.2 Gebrauchstauglichkeit	
2.7.3 Identifikation	Siehe Anhang A

*) Siehe Seite 7 dieser Europäischen Technischen Zulassung

**) Entsprechend <http://europa.eu.int/-/comm/enterprise/construction/internal/dangsub/dangmain.htm> Zusätzlich zu den spezifischen Klauseln in dieser Europäischen Technischen Zulassung, die sich auf gefährliche Substanzen beziehen, können weitere Anforderungen an die Produkte, die in diesen Bereich fallen, bestehen (z. B. umgesetzte europäische Gesetzgebung und einzelstaatliche Gesetze, Bestimmungen und Verwaltungsvorschriften). Zur Einhaltung der Regelungen der EU-Bauprodukttrichtlinie muss diesen Anforderungen, sofern zutreffend, entsprochen werden.

2.1 Mechanische Beständigkeit und Stabilität

Die Tragfähigkeiten der „fischer Power-Fast“-Schrauben und „fischer Holzbauschrauben FCS“ gelten ebenfalls für die in Ziffer 1 genannten Holzwerkstoffe, wenn auch nachstehend nur der Begriff Holz verwendet wird.

Der charakteristische Wert der Quertragfähigkeit und der charakteristische Wert der axialen Ausziehtragfähigkeit der „fischer Power-Fast“-Schrauben und der „fischer Holzbauschrauben FCS“ sollten bei Konstruktionen gemäß Eurocode 5 oder einer entsprechenden nationalen Norm verwendet werden.

Die Eindringtiefe des Gewindeteils ab Schraubenspitze muss $\ell_{ef} \geq 4 \cdot d$ betragen, wobei d der Gewindeaußendurchmesser der Schraube ist. Zur Befestigung von Sparren muss die Eindringtiefe ab Schraubenspitze mindestens 40 mm, $\ell_{ef} \geq 40$ mm betragen.

Etwaige für die tragenden Bauteile vorhandene Europäische Technische Zulassungen sind gegebenenfalls zu berücksichtigen.

Etwaige für die Holzwerkstoffplatten vorhandene Europäische Technische Zulassungen sind gegebenenfalls zu berücksichtigen.

Tragfähigkeit rechtwinklig zur Schraubenachse

Der charakteristische Wert der Quertragfähigkeit der „fischer Power-Fast“-Schrauben und „fischer Holzbauschrauben FCS“ ist nach EN 1995-1-1:2008 (Eurocode 5) mit dem Gewindeaußendurchmesser d als Nenndurchmesser der Schraube zu berechnen. Die Wirkung des Seileinhangeffekts darf dabei berücksichtigt werden.

Der charakteristische Wert des Fließmoments ist wie folgt zu berechnen:

Schrauben aus Kohlenstoffstahl mit $3,0 \text{ mm} \leq d \leq 3,5 \text{ mm}$ und 12 mm :

$$M_{y,k} = 0,15 \cdot 500 \text{ (N/mm}^2\text{)} \cdot d^{2,6} \quad [\text{Nmm}]$$

Schrauben aus Kohlenstoffstahl mit $4,0 \text{ mm} \leq d \leq 10,0 \text{ mm}$:

$$M_{y,k} = 0,15 \cdot 600 \text{ (N/mm}^2\text{)} \cdot d^{2,6} \quad [\text{Nmm}]$$

Schrauben aus Edelstahl mit $3,0 \text{ mm} < d < 6,0 \text{ mm}$:

$$M_{y,k} = 0,15 \cdot 350 \text{ (N/mm}^2\text{)} \cdot d^{2,6} \quad [\text{Nmm}]$$

Schrauben aus Edelstahl mit $d = 8,0 \text{ mm}$:

$$M_{y,k} = 0,15 \cdot 500 \text{ (N/mm}^2\text{)} \cdot d^{2,6} \quad [\text{Nmm}]$$

darin ist

d Gewindeaußendurchmesser [mm]

Axialer Auszieh Widerstand

Der charakteristische Wert des axialen Auszieh Widerstandes der „fischer Power-Fast“-Schrauben und der „fischer Holzbauschrauben FCS“ in Bauteilen aus Vollholz (Nadelholz), Brettschichtholz, oder Brettsperholz bei einem Winkel von $0^\circ \leq \alpha \leq 90^\circ$ zur Faserrichtung ist gemäß EN 1995-1-1:2008 nach folgender Gleichung zu berechnen:

$$F_{ax,\alpha,Rk} = n_{ef} \cdot k_{ax} \cdot f_{ax,k} \cdot d \cdot \ell_{ef} \cdot \left(\frac{\rho_k}{350} \right)^{0,8} \quad [\text{N}]$$

darin sind

$F_{ax,\alpha,Rk}$	Charakteristischer Wert des Auszieh Widerstands der Verbindung unter einem Winkel α zur Faserrichtung [N]
n_{ef}	Effektiv wirksame Anzahl der Schrauben gemäß EN 1995-1-1:2008
k_{ax}	Faktor zur Berücksichtigung des Winkels α zwischen Schraubenachse und Faserrichtung $k_{ax} = 1,0$ bei $45^\circ \leq \alpha < 90^\circ$ $k_{ax} = 0,3 + \frac{0,7 \cdot \alpha}{45}$ bei $0^\circ \leq \alpha < 45^\circ$
$f_{ax,k}$	Charakteristischer Ausziehparameter Schrauben $\varnothing = 3,0 \text{ mm}$: $f_{ax,k} = 13,8 \text{ N/mm}^2$ Schrauben $\varnothing = 3,5 \text{ mm}$: $f_{ax,k} = 13,4 \text{ N/mm}^2$ Schrauben $\varnothing = 4,0 \text{ mm}$: $f_{ax,k} = 13,0 \text{ N/mm}^2$ Schrauben $\varnothing = 4,5 \text{ mm}$: $f_{ax,k} = 12,6 \text{ N/mm}^2$ Schrauben $\varnothing = 5,0 \text{ mm}$: $f_{ax,k} = 12,2 \text{ N/mm}^2$ Schrauben $\varnothing = 6,0 \text{ mm}$: $f_{ax,k} = 11,6 \text{ N/mm}^2$ Schrauben $\varnothing \geq 8,0 \text{ mm}$: $f_{ax,k} = 10,0 \text{ N/mm}^2$
d	Gewindeaußendurchmesser [mm]
ℓ_{ef}	Eindringtiefe des Gewindeteils ab Schraubenspitze gemäß EN 1995-1-1:2008 [mm]
α	Winkel zwischen Faserrichtung und Schraubenachse ($\alpha \geq 30^\circ$)
ρ_k	Charakteristische Rohdichte [kg/m^3]

Der axiale Auszieh Widerstand wird durch den Durchzieh Widerstand und die Zugtragfähigkeit der Schraube begrenzt.

Durchzieh Widerstand

Der charakteristische Durchzieh Widerstand der „fischer Power-Fast“-Schrauben und der „fischer Holzbauschrauben FCS“ ist gemäß EN 1995-1-1:2008 nach folgender Gleichung zu ermitteln:

$$F_{ax,\alpha,Rk} = n_{ef} \cdot f_{head,k} \cdot d_h^2 \cdot \left(\frac{\rho_k}{350} \right)^{0,8} \quad [\text{N}]$$

darin sind:

$F_{ax,\alpha,Rk}$ Charakteristischer Durchzieh Widerstand der Verbindung bei einem Winkel $\alpha \geq 30^\circ$ zur Faserrichtung [N]

n_{ef}	Effektiv wirksame Anzahl der Schrauben gemäß EN 1995-1-1:2008
$f_{head,k}$	Charakteristischer Durchziehparameter [N/mm ²]
d_h	Schraubenkopfdurchmesser [mm]
ρ_k	Charakteristische Rohdichte [kg/m ³], für Holzwerkstoffplatten $\rho_k = 380 \text{ kg/m}^3$

Charakteristischer Durchziehparameter für Schrauben mit einem Schraubenkopfdurchmesser $\leq 21 \text{ mm}$ in Verbindungen mit Holz und Holzwerkstoffen mit einer Dicke von über 20 mm:

$$f_{head,k} = 12 \text{ N/mm}^2$$

Charakteristischer Durchziehparameter für Schrauben mit einem Schraubenkopfdurchmesser $21 \text{ mm} < d_h \leq 35 \text{ mm}$ in Verbindungen mit Holz und Holzwerkstoffen mit einer Dicke von über 20 mm:

$$f_{head,k} = 10 \text{ N/mm}^2$$

Charakteristischer Durchziehparameter für Schrauben in Verbindungen mit Holzwerkstoffen mit einer Stärke zwischen 12 mm und 20 mm:

$$f_{head,k} = 8 \text{ N/mm}^2$$

Schrauben in Verbindungen mit Holzwerkstoffen mit einer Dicke von unter 12 mm (Mindestdicke für Holzwerkstoffe beträgt $1,2 \cdot d$, wobei d den Gewindeaußendurchmesser beschreibt):

$$f_{head,k} = 8 \text{ N/mm}^2$$

begrenzt auf $F_{ax,Rk} = 400 \text{ N}$

Der Schraubenkopfdurchmesser d_h muss größer sein als $1,8 \cdot d_s$, wobei d_s dem glatten Schraubenschaft bzw. dem Kerndurchmesser entspricht. Ansonsten beträgt der charakteristische Durchziehparameter $F_{ax,\alpha,Rk} = 0$.

Außendurchmesser der Unterlegscheiben von $d_h > 35 \text{ mm}$ dürfen nicht berücksichtigt werden.

Die Mindestdicke des Holzwerkstoffes nach Ziffer 2.1 ist einzuhalten.

In Stahl-Holz-Verbindungen ist der Durchziehparameter nicht maßgebend.

Zugfestigkeit

Der charakteristische Wert der Zugtragfähigkeit $f_{tens,k}$ der „fischer Power-Fast“-Schrauben und der „fischer Holzbauschrauben FCS“ beträgt:

Schrauben aus Kohlenstoffstahl:

Schraube $d = 3,0 \text{ mm}$:	2,7 kN
Schraube $d = 3,5 \text{ mm}$:	3,7 kN
Schraube $d = 4,0 \text{ mm}$:	4,8 kN
Schraube $d = 4,5 \text{ mm}$:	6,0 kN
Schraube $d = 5,0 \text{ mm}$:	7,5 kN
Schraube $d = 6,0 \text{ mm}$:	10,7 kN
Schraube $d = 8,0 \text{ mm}$:	19,1 kN

Schraube $d = 10,0 \text{ mm}$:	29,8 kN
Schraube $d = 12,0 \text{ mm}$:	32,7 kN

Schrauben aus Edelstahl:

Schraube $d = 3,0 \text{ mm}$:	1,6 kN
Schraube $d = 3,5 \text{ mm}$:	2,1 kN
Schraube $d = 4,0 \text{ mm}$:	2,8 kN
Schraube $d = 4,5 \text{ mm}$:	3,5 kN
Schraube $d = 5,0 \text{ mm}$:	4,3 kN
Schraube $d = 6,0 \text{ mm}$:	6,2 kN
Schraube $d = 8,0 \text{ mm}$:	13,0 kN

Bei Schrauben, die in Verbindungen mit Stahlplatten verwendet werden, muss die Abreißfestigkeit des Schraubenkopfes größer sein als die Zugfestigkeit der Schraube.

Schrauben mit kombinierter Quer- und Zugbeanspruchung

Bei Verschraubungen, die einer kombinierten axialen und Querbeanspruchung ausgesetzt sind, muss die folgende Bedingung erfüllt sein:

$$\left(\frac{F_{ax,Ed}}{F_{ax,Rd}} \right)^2 + \left(\frac{F_{la,Ed}}{F_{la,Rd}} \right)^2 \leq 1$$

darin sind

$F_{ax,Ed}$	Bemessungswert der einwirkenden Last in Achsrichtung der Schraube
$F_{la,Ed}$	Bemessungswert der einwirkenden Last rechtwinklig zur Schraubachse
$F_{ax,Rd}$	Bemessungswert der Zugtragfähigkeit der Schraube
$F_{la,Rd}$	Bemessungswert der Quertragfähigkeit der Schraube

Verschiebungsmodul

Der axiale Verschiebungsmodul K_{ser} einer Schraube beträgt für den Grenzzustand der Gebrauchstauglichkeit unabhängig vom Winkel α zur Faserrichtung:

$$C = K_{ser} = 780 \cdot d^{0,2} \cdot \ell_{ef}^{0,4} \quad [\text{N/mm}]$$

Dabei sind

d	Gewindeaußendurchmesser [mm]
ℓ_{ef}	Einbindetiefe in das Bauteil [mm]

Befestigung von Aufdachdämmsystemen

„fischer Power-Fast“-Schrauben und „fischer Holzbauschrauben FCS“ mit einem Gewindeaußendurchmesser von $d = 6 \text{ mm}$, 8 mm , 10 mm und 12 mm können für die Befestigung von Aufsparrendämmung verwendet werden.

Die Dämmstoffdicke darf bis zu 300 mm betragen. Die Sparrendämmung ist auf Sparren aus Vollholz oder Brettschichtholz oder Bauteilen aus Brettsperrholz

anzubringen und mittels parallel zu den Sparren angeordneter Konterlatten oder auf der Dämmschicht angebrachter Holzwerkstoffplatten zu befestigen. Dies gilt sinngemäß auch für die Dämmung vertikaler Fassaden.

Die Schrauben sind ohne Vorbohren in einem Arbeitsgang durch die Konterlatten oder -platten und den Dämmstoff in die Sparren einzuschrauben.

Der Winkel α zwischen der Schraubenachse und der Faserrichtung der Sparren sollte zwischen 30° und 90° betragen.

Die Latten müssen aus Vollholz (Nadelholz) gemäß EN 338:2003-04 bestehen. Die Mindestdicke der Latten beträgt 80 mm, die Mindestbreite 100 mm für Schrauben mit einem Gewindeaußendurchmesser $d = 12$ mm. Die Mindestdicke der Latten beträgt 40 mm, die Mindestbreite 60 mm für Schrauben mit einem Gewindeaußendurchmesser $d = 10$ mm. Für Schrauben mit einem Gewindeaußendurchmesser $d = 6$ mm und 8 mm beträgt die Mindestdicke der Latten 30 mm und die Mindestbreite 50 mm.

Als Alternative zu den Latten können, jeweils mit einer Mindestdicke von 20 mm, auch Sperrholzplatten gemäß EN 636, Spanplatten gemäß EN 312, Grobspanplatten des Typs OSB/3 und OSB/4 gemäß EN 300 oder Europäischer Technischer Zulassung oder Vollholzplatten gemäß EN 13353 verwendet werden.

Die Sparren müssen aus Vollholz (Nadelholz) gemäß EN 338, Brettschichtholz gemäß EN 14081, Brettsperrholz, Furnierschichtholz gemäß EN 14374 oder Europäischer Technischer Zulassung oder ähnlichen verleimten Holzbauteilen gemäß Europäischer Technischer Zulassung bestehen und eine Mindestbreite von 60 mm aufweisen.

Der Dämmstoff muss einer Europäischen Technischen Zulassung entsprechen.

Der Dämmstoff muss eine Druckspannung von mindestens $\sigma_{10\%} = 0,05$ N/mm² bei 10 % Stauchung gemäß EN 826:1996-05 aufweisen.

Die Befestigung des Dämmstoffs und der Konterlatten bzw. Platten kann anhand des in Anhang B dargestellten Statik-Modells rechnerisch erfasst werden. Die Latten bzw. Platten müssen eine ausreichende Festigkeit und Steifigkeit aufweisen. Der maximale Druck zwischen Latten bzw. Platten und dem Dämmstoff darf $1,1 \cdot \sigma_{10\%}$ nicht übersteigen.

Der charakteristische Wert der axialen Ausziehtragfähigkeit der Schrauben bei Aufsparren- oder Fassadendämmung errechnet sich wie folgt:

$$F_{ax,\alpha,Rk} = \min \left\{ \begin{array}{l} k_{ax} \cdot f_{ax,k} \cdot d \cdot \ell_{ef} \cdot k_1 \cdot k_2 \left(\frac{\rho_k}{350} \right)^{0,8} \\ f_{head,k} \cdot d_h^2 \cdot \left(\frac{\rho_k}{350} \right)^{0,8} \end{array} \right. \quad [N]$$

hierin sind

$F_{ax,\alpha,Rk}$	Charakteristischer Wert des Ausziehwidestands der Verbindung unter einem Winkel α zur Faserrichtung [N]
k_{ax}	Faktor zur Berücksichtigung des Winkels α zwischen Schraubenachse und Faserrichtung $k_{ax} = 1,0$ für $45^\circ \leq \alpha < 90^\circ$ $k_{ax} = 0,3 + \frac{0,7 \cdot \alpha}{45}$ bei $0^\circ \leq \alpha < 45^\circ$
$f_{ax,k}$	Charakteristischer Ausziehparameter [N/mm ²]
d	Gewindeaußendurchmesser [mm]
ℓ_{ef}	Einschraubtiefe des Gewindeteils ab Schraubenspitze gemäß EN 1995-1-1:2008 [mm]
α	Winkel zwischen Faserrichtung und Schraubenachse ($\alpha \geq 30^\circ$)
k_1	min. {1; $220/t_{HI}$ }
k_2	min. {1; $\sigma_{10\%}/0,12$ }
t_{HI}	Dämmstoffdicke [mm]
$\sigma_{10\%}$	Druckspannung des Dämmstoffs bei 10 % Stauchung [N/mm ²] $\sigma_{10\%} \geq 0,05$ N/mm ²
$f_{head,k}$	Charakteristischer Durchziehparameter [N/mm ²]
d_h	Außendurchmesser des Schraubenkopfes [mm]
ρ_k	Charakteristische Rohdichte [kg/m ³]

Reibungskräfte sind bei der Ermittlung des charakteristischen Werts des Ausziehwidestands der Schrauben nicht zu berücksichtigen.

Die axiale Ausziehtragfähigkeit ist durch den Durchziehwidestand begrenzt (siehe 2.1).

Die Verankerung gegen Windsogkräfte sowie die Biegespannungen in den Konterlatten bzw. Platten sind bei der Bemessung zu berücksichtigen. Falls erforderlich können zusätzliche Schrauben senkrecht zur Faserrichtung der Sparren (Winkel $\alpha = 90^\circ$) eingeschraubt werden.

Zur Verankerung der Aufsparrendämmung sind die Schrauben gemäß Anhang B anzuordnen.

Der Schraubenabstand darf maximal $e_s = 1,75$ m betragen.

2.7 Weitere Anmerkungen zur Gebrauchstauglichkeit

2.7.1 Korrosionsschutz in Nutzungsklasse 1, 2 und 3.

„fischer Power-Fast“-Schrauben und „fischer Holzbauschrauben FCS“ werden aus Kohlenstoffstahldraht hergestellt. Aus Kohlenstoffstahl hergestellte Schrauben sind galvanisch verzinkt und gelb oder blau chromatiert. Die mittlere Zink-Schichtdicke beträgt 5µm.

Angaben über die Güte der Schrauben aus Edelstahl sind bei der ETA-Danmark hinterlegt.

3 Konformitätsbescheinigung und CE-Kennzeichnung

3.1 System der Konformitätsbescheinigung

Das System der Konformitätsscheinigung ist 2+, beschrieben in der Richtlinie 89/106/EWG des Rates (Bauprodukterichtlinie) Anhang III.

- a) Aufgaben des Herstellers:
- (1) Werkseigene Produktionskontrolle,
 - (2) Erstprüfung des Produkts,
- b) Aufgaben der benannten Stelle:
- (1) Erstinspektion der Fabrik und der werkseigenen Produktionskontrolle,
 - (2) Fortlaufende Überwachung

3.2 Zuständigkeiten

3.2.1 Aufgaben des Herstellers

3.2.1.1 Werkseigene Produktionskontrolle

Der Hersteller verfügt über ein werkseigenes Produktionskontrollsystem und führt permanent innerbetriebliche Produktionskontrollen durch. Alle vom Hersteller berücksichtigten Grundlagen, Anforderungen und Vorschriften sind systematisch in Form schriftlicher Richtlinien und Verfahrensanweisungen zusammenzustellen. Dieses Produktionskontrollsystem gewährleistet, dass das Produkt der Europäischen Technischen Zulassung entspricht.

Der Hersteller verwendet ausschließlich Rohmaterial, das mit einschlägigen Kontrolldokumenten wie im Kontrollplan⁴ dargelegt geliefert wird. Angeliefertes Rohmaterial ist vor Annahme Kontrollen und Tests durch den Hersteller zu unterziehen. Die Prüfung von Material wie zum Beispiel Blech umfasst die Kontrolle der von den Lieferanten vorgelegten Inspektionsdokumente (Vergleich mit Nennwerten) durch Überprüfung der Ausmaße und der Bestimmung der Materialeigenschaften.

Die hergestellten Bauteile werden folgenden Prüfungen unterzogen:

- Rohmaterialspezifikation;

- Schraubenabmessung;
- Charakteristische Zugfestigkeit $f_{tens,k}$;
- Charakteristische Torsionsfestigkeit $f_{tor,k}$;
- Charakteristisches Einschraubmoment $R_{tor,k}$;
- Haltbarkeit;
- Kennzeichnung.

Der Kontrollplan, der Bestandteil der technischen Dokumentation dieser Europäischen Technischen Zulassung ist, berücksichtigt Einzelheiten zum Ausmaß, der Natur und Häufigkeit der Tests und Kontrollen, die im Rahmen der werkseigenen Produktionskontrolle auszuführen sind. Er wurde vom Zulassungsinhaber und ETA Dänemark vereinbart.

Die Ergebnisse der werkseigenen Produktionskontrolle werden aufgezeichnet und ausgewertet. Die Aufzeichnungen enthalten mindestens folgende Informationen:

- Bezeichnung des Produkts, des Ausgangsmaterials und der Komponenten;
- Art der Kontrolle bzw. Tests;
- Herstellungsdatum des Produkts und Datum der Produkttests bzw. der Tests des Ausgangsmaterials oder der Komponenten;
- Kontroll- und Testergebnisse sowie gegebenenfalls Vergleich mit den Anforderungen;
- Unterschrift der für die werkseigene Produktionskontrolle zuständigen Person.

Die Unterlagen sind der ETA Dänemark auf Anfrage vorzulegen.

3.2.1.1 Erstprüfung des Produkts

Für die Erstprüfung sind die Ergebnisse der Tests heranzuziehen, die im Rahmen der Begutachtung für die Europäische Technische Zulassung ausgeführt wurden, es sei denn, es haben sich bei Produktionsanlage oder -betrieb Änderungen ergeben. In solchen Fällen muss die erforderliche Erstprüfung zwischen ETA Dänemark und der benannten Stelle abgestimmt werden.

Die Erstprüfung erstreckt sich auf folgende Prüfungen:

- Rohmaterialspezifikation;
- Schraubenabmessung;
- Charakteristisches Fließmoment $M_{y,k}$;
- Charakteristischer Ausziehparameter $f_{ax,k}$;
- Charakteristischer Kopfdurchzugparameter $f_{head,k}$;
- Charakteristische Zugfestigkeit $f_{tens,k}$;
- Charakteristische Streckgrenze, soweit relevant;

4 Der Kontrollplan ist bei ETA-Dänemark hinterlegt und wird nur den zugelassenen Stellen, die am Prozess der Erstellung des Konformitätsnachweises beteiligt sind, zur Verfügung gestellt.

- Charakteristische Torsionsfestigkeit $f_{\text{tor,k}}$;
- Charakteristisches Einschraubmoment $R_{\text{tor,k}}$;
- Haltbarkeit

3.2.2. Aufgaben der zugelassenen Stellen

3.2.2.1 Erstinspektion des Werkes und der werkseigenen Produktionskontrolle

Die zugelassene Stelle sollte sicherstellen, dass entsprechend des Prüfplans die Fertigungsstätte, insbesondere die Mitarbeiter und die Ausrüstung sowie die werkseigene Produktionskontrolle geeignet sind, eine fortlaufende und ordnungsgemäße Herstellung der Schrauben gemäß den Spezifikationen in Teil 2 zu gewährleisten.

3.2.2.2 Fortlaufende Überwachung

Die zugelassene Stelle besucht die Fertigungsstätte zwecks Durchführung von Routinekontrollen mindestens einmal jährlich. Es ist zu überprüfen, ob das System der werkseigenen Produktionskontrolle und die vorgegebenen Fertigungsprozesse unter Berücksichtigung des Prüfplanes eingehalten werden.

Die Ergebnisse der Produktzertifizierung und der fortlaufenden Überwachung sind auf Anfrage der Zertifizierungsstelle ETA Dänemark zur Verfügung zu stellen. Werden die Bestimmungen der Europäischen Technischen Zulassung und des Kontrollplanes nicht mehr erfüllt, so wird das Konformitätszertifikat von der zugelassenen Stelle entzogen.

3.3 CE-Kennzeichnung

Die CE-Kennzeichnung ist an jeder Packung Schrauben anzubringen. Dem Kürzel „CE“ folgt die Identifikationsnummer der benannten Stelle, ergänzt durch folgende Informationen:

- Name bzw. Erkennungszeichen des Herstellers
- Die letzten beiden Ziffern des Jahres der Anbringung der CE-Kennzeichnung
- Nummer der Europäischen Technischen Zulassung
- Bezeichnung des Produkts
- Gewindeaußendurchmesser und Länge der Selbstbohrschrauben
- Art und mittlere Stärke des Korrosionsschutzes
- Nummer des EU-Konformitätszertifikats

4 Annahmen, die zu einer positiven Bewertung der Brauchbarkeit des Produkts für den vorgesehenen Verwendungszweck führten

4.1 Fertigung

fischer Power-Fast-Schrauben und fischer Holzbauschrauben FCS werden gemäß den Bestimmungen dieser Europäischen Technischen Zulassung unter Anwendung des Herstellungsverfahrens hergestellt, das die benannte Prüfstelle bei der Inspektion der Fertigungsanlage ermittelt und in der technischen Dokumentation festgehalten hat.

4.2 Einbau

4.2.1 Der Einbau hat gemäß Eurocode 5 oder einer entsprechenden nationalen Norm zu erfolgen, es sei denn, nachstehend wurden andere Festlegungen getroffen. Die Einbauanleitungen der fischerwerke GmbH Co. KG müssen berücksichtigt werden.

4.2.2 Die Schrauben sind in tragenden Holzkonstruktionen zur Verbindung von Teilen aus Vollholz (Nadelholz), Brettschichtholz, Brettspertholz (min. $d = 6,0$ mm), Furnierschichtholz, ähnlich verleimten Holzbauteilen, Holzwerkstoffplatten oder von Stahlteilen bestimmt.

Die Schrauben können in tragenden Holzkonstruktionen zur Verbindung von Bauteilen gemäß einer etwaigen Europäischen Technischen Zulassung des Bauteils verwendet werden, sofern gemäß der Europäischen Technischen Zulassung des tragenden Bauteils der Einbau in tragende Holzkonstruktionen mit Schrauben zulässig ist.

Zudem können die Schrauben mit Durchmesser von 6 mm bis 12 mm zur Befestigung von Aufdach-Dämmsystemen auf Sparren oder zur Befestigung von Wärmedämmung an vertikalen Fassaden eingesetzt werden.

Bei Verbindungen in tragenden Holzkonstruktionen müssen jeweils mindestens zwei Schrauben verwendet werden.

Die Mindesteinschraubtiefe in Bauteile aus Vollholz, Brettschichtholz oder Brettspertholz beträgt $4 \cdot d$.

Holzwerkstoffplatten und Stahlplatten sollten nur auf der Seite des Schraubenkopfes angebracht werden. Holzwerkstoffplatten sollten eine Dicke von mindestens $1,2 \cdot d$ aufweisen. Zudem sollten bei folgenden Holzwerkstoffen die jeweiligen Mindestdicken beachtet werden:

- Sperrholz, Faserplatten: 6 mm
- Spanplatten, OSB-Platten, zementgebundene Spanplatten: 8 mm
- Vollholzplatten: 12 mm

Für Bauteile nach Europäischer Technischer Zulassung sind die Bedingungen der jeweils einschlägigen Europäischen Technischen Zulassung zu berücksichtigen.

Werden Schrauben mit einem Gewindeaußendurchmesser von $d \geq 8$ mm in tragenden Holzkonstruktionen verwendet, so müssen das Vollholz, Brettschichtholz, Furnierschichtholz und ähnlich verleimte Bauteile aus Fichten-, Kiefern- oder Tannenholz bestehen. Dies gilt nicht für das Einschrauben in vorgebohrte Löcher.

Der Winkel zwischen der Schraubenachse und der Faserrichtung muss mindestens $\alpha = 0^\circ$ betragen.

4.2.3 Schrauben dürfen in Holz mit oder ohne Vorbohren eingedreht werden, wobei der Bohrdurchmesser der Vorbohrung über die gesamte Länge des Gewindebereiches nicht größer als der Kerndurchmesser und im Bereich des glatten Schafts nicht größer als der Schaftdurchmesser sein darf.

Bei Stahlteilen sind die Löcher mit einem angemessenen Durchmesser vorzubohren

Für das Eindrehen der Schrauben ist ausschließlich das von der fischerwerke GmbH Co. KG benannte Werkzeug zu verwenden.

In Verbindungen mit Senkkopfschrauben gemäß Anhang A1 bis A4, A7 und A12 muss der Schraubenkopf bündig mit der Oberfläche des Anbauteils abschließen. Ein tieferes Versenken ist nicht zulässig. Dies gilt gleichermaßen für Pan Head- und Tellerkopf-Schrauben mit Ausnahme der Schraubenkopfhöhe k .

Senkkopfschrauben aus Kohlenstoffstahl nach Anhang A2 bis A5, A7, A8 und A12 können zusammen mit Unterlegscheiben gemäß Anhang A14 verwendet werden. Die Unterlegscheiben müssen vollflächig anliegen.

4.2.4 Für Holzbauteile gibt EN 1995-1:2008 (Eurocode 5) in Abschnitt 8.3.1.2 sowie in Tabelle 8.2 jeweils Mindestabstände für Schrauben in vorgebohrte Löcher wie für Nägel in vorgebohrte Nagellöcher an, wobei der Gewindeaußendurchmesser d in Rechnung zu stellen ist.

EN 1995-1-1:2008 (Eurocode 5) gibt in Abschnitt 8.3.1.2 sowie in Tabelle 8.2 jeweils Mindestabstände für Schrauben ohne Vorbohren wie für Nägel ohne Vorbohren an.

Alternativ können die Mindeststrand- und Achsabstände von ausschließlich axial beanspruchten "fischer Power-Fast"-Schrauben in nicht vorgebohrten Bauteilen aus Vollholz, Brettschichtholz oder ähnlichen verleimten Holzbauteilen mit einer Mindestdicke $t = 12 \cdot d$ und einer Mindestbreite von $8 \cdot d$ oder 60 mm (es gilt der jeweils höhere Wert) wie folgt ermittelt werden:

Achsabstand a_1 parallel zur Faser

$$a_1 = 5 \cdot d$$

Achsabstand a_2 senkrecht zur Faser	$a_2 = 5 \cdot d$	Stirnfläche senkrecht zur Faser der Decklage	$a_{4,t} = 6 \cdot d$
Abstand $a_{3,c}$ vom Schwerpunkt des im Holz eingedrehten Schraubenteils zur Hirnholzfläche	$a_{3,c} = 9 \cdot d$	Soweit in der technischen Spezifikation (ETA oder hEN) von Brettsperrholz keine anderen Vorgaben enthalten sind, lassen sich für in der Stirnfläche in Bauteilen aus Brettsperrholz mit einer Mindestdicke $t = 10 \cdot d$ und einer Mindesteinbindetiefe von $10 \cdot d$ senkrecht zur Stirnfläche eingedrehte Schrauben jeweils folgende Werte für die Mindeststrand- und Achsabstände ermitteln (vgl. Anhang C):	
Abstand $a_{4,c}$ vom Schwerpunkt des im Holz eingeschraubten Schraubenteils zur Seitenfläche	$a_{4,c} = 4 \cdot d$	Achsabstand a_1 parallel zur Fläche des Brettsperrholzes	$a_1 = 10 \cdot d$
Der Achsabstand a_2 senkrecht zur Faserrichtung kann von $5 \cdot d$ auf $2,5 \cdot d$ verringert werden, sofern die Bedingung $a_1 \cdot a_2 \geq 25 \cdot d^2$ erfüllt ist.		Achsabstand a_2 senkrecht zur Fläche des Brettsperrholzes	$a_2 = 4 \cdot d$
Bei Bauteilen aus Douglasie sind die Mindeststrand- und Achsabstände in Faserrichtung um 50 % zu vergrößern.		Abstand $a_{3,c}$ vom Schwerpunkt des im Holz eingedrehten Schraubenteils zur unbeanspruchten Stirnfläche	$a_{3,c} = 7 \cdot d$
Der Mindestabstand zum beanspruchten oder unbeanspruchten Rand muss bei nicht vorgebohrten Löchern und Schrauben mit einem Gewindeaußendurchmesser von $d \geq 8$ mm sowie einer Holzdicke $t < 5 \cdot d$ mindestens $15 \cdot d$ betragen.		Abstand $a_{3,t}$ vom Schwerpunkt des im Holz eingedrehten Schraubenteils zur beanspruchten Stirnfläche	$a_{3,t} = 12 \cdot d$
Der Mindestabstand zum unbeanspruchten Rand senkrecht zur Faserrichtung kann auch bei einer Holzdicke $t < 5 \cdot d$ auf $3 \cdot d$ verringert werden, sofern der Abstand der Schrauben in Faserrichtung verläuft und zum Hirnholzende mindestens $25 \cdot d$ beträgt.		Abstand $a_{4,c}$ vom Schwerpunkt des im Holz eingedrehten Schraubenteils zur unbeanspruchten Seitenfläche	$a_{4,c} = 3 \cdot d$
Soweit in der technischen Spezifikation (ETA oder hEN) von Brettsperrholz keine anderen Vorgaben enthalten sind, lassen sich für Schrauben, die in die Seitenfläche von Bauteilen aus Brettsperrholz mit einer Mindestdicke $t = 10 \cdot d$ eingeschraubt werden, jeweils folgende Werte für die Mindeststrand- und Achsabstände (vgl. Anhang C) ermitteln:		Abstand $a_{4,t}$ vom Schwerpunkt des im Holz eingedrehten Schraubenteils zur beanspruchten Seitenfläche	$a_{4,t} = 6 \cdot d$
Achsabstand a_1 parallel zur Faser	$a_1 = 4 \cdot d$	Bei gekreuzt angeordneten Schraubenpaaren beträgt der Mindestachsabstand der gekreuzten Schrauben $1,5 \cdot d$.	
Achsabstand a_2 senkrecht zur Faser	$a_2 = 2,5 \cdot d$	Die Mindestdicke der Holzbauteile beträgt $t = 24$ mm für Schrauben mit einem Gewindeaußendurchmesser $d < 8$ mm sowie $t = 30$ mm für Schrauben mit einem Gewindeaußendurchmesser $d = 8$ mm, $t = 40$ mm für Schrauben mit einem Gewindeaußendurchmesser $d = 10$ mm und $t = 80$ mm für Schrauben mit einem Gewindeaußendurchmesser $d = 12$ mm.	
Abstand $a_{3,c}$ vom Schwerpunkt des im Holz eingedrehten Schraubenteils zur unbeanspruchten Stirnfläche parallel zur Faser der Decklage	$a_{3,c} = 6 \cdot d$		
Abstand $a_{3,t}$ vom Schwerpunkt des im Holz eingedrehten Schraubenteils zur beanspruchten Stirnfläche parallel zur Faser der Decklage	$a_{3,t} = 6 \cdot d$		
Abstand $a_{4,c}$ vom Schwerpunkt des im Holz eingedrehten Schraubenteils zur unbeanspruchten Stirnfläche senkrecht zur Faser der Decklage	$a_{4,c} = 2,5 \cdot d$		
Abstand $a_{4,t}$ vom Schwerpunkt des im Holz eingedrehten Schraubenteils zur beanspruchten			

4.3 Instandhaltung und Reparatur

Während der vorgesehenen Nutzungsdauer ist keine Instandhaltung erforderlich. Sollte eine Reparatur nötig werden, wird die Schraube üblicherweise ausgetauscht.

Thomas Bruun
Manager, ETA-Danmark

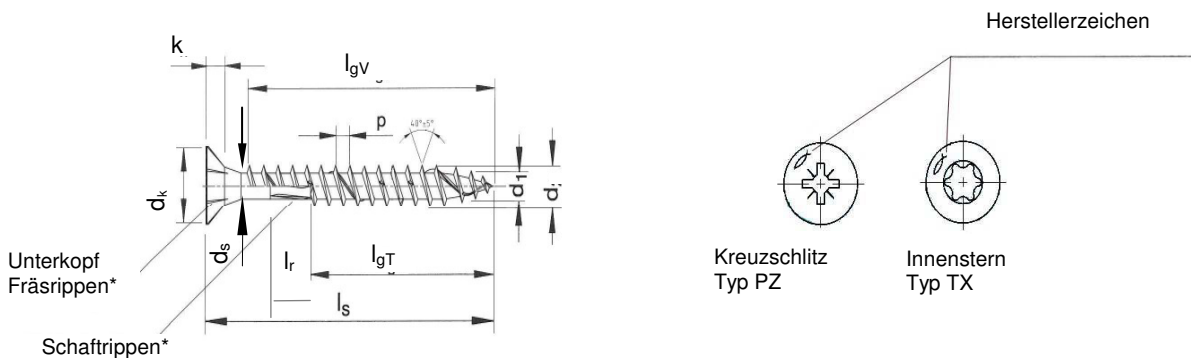

* optional

Selbstbohrende Schraube (Senkkopf) mit Voll- oder Teilgewinde																		
Nenndurchmesser		3,0	3,5	4,0	4,5	5,0	6,0											
d	Gewindegröße	3,15	3,65	4,15	4,65	5,15	6,15											
	zul. Abw.	-0,40																
d1	Kerndurchmesser	2,00	2,20	2,50	2,70	3,10	3,80											
	zul. Abw.	-0,25 / +0,10				-0,30 / +0,10												
dk	Kopfdurchmesser	6,00	7,00	8,00	8,80	9,70	11,60											
	zul. Abw.	-0,50 / +0,10																
ds	Schaftdurchmesser	2,25	2,55	2,90	3,25	3,55	4,30											
	zul. Abw.	-0,30 / +0,10																
k	Kopfhöhe	1,90	2,10	2,50	2,70	3,00	3,40											
p	Gewindesteigung	1,50	1,80	2,00	2,20	2,50	3,00											
	zul. Abw.	±10%																
lr*	Schaftrippenlänge	3,75	4,25	4,75	5,5	6,0	7,0											
	zul. Abw.	±0,75			±1,0													
Innensterngröße TX		10			20			30										
Kreuzschlitzgröße Typ PZ		1		2				3										
Nennmaß		ls		Standardgewindelängen										Toleranz: ± 2,0				
		min	max	lgv		lgt		lgv		lgt		lgv		lgt				
20		18,95	21,05			16												
25		23,75	26,25	21		21	18	20										
30		28,75	31,25	26	18	26	18	25	18	25	18	24						
35		33,50	36,50	31	24	31	24	30	24	30	24	29	24	28				
40		38,50	41,50	36	24	36	24	35	24	35	24	34	24	33	24			
45		43,50	46,50	41	30	41	30	40	30	40	30	39	30	38	30			
50		48,50	51,50			46	30	45	30	45	30	44	30	43	30			
55		53,50	56,50					50	36	50	36	49	36	48				
60		58,50	61,50						36		36		36	53	36			
70		68,50	71,50						42		42		42	63	42			
80		78,50	81,50						50		50		50	73	50			
90		88,25	91,75										60		60			
100		98,25	101,75										60		60			
110		108,25	111,75										70		70			
120		118,25	121,75										70		70			
130		128,00	132,00												70			
140		138,00	142,00												70			
150		148,00	152,00												70			
160		158,00	162,00												70			
180		178,00	182,00												70			
bis																		
300		298,00	302,00												70			

Zwischenlängen bei ls sind möglich.

Alle Maße in mm

Mögliche Oberflächenbehandlungen: galvanisch verzinkt, gelb passiviert; galvanisch verzinkt, blau passiviert; Bonuszink; brüniert; vernickelt; vermessingt.

Werkstoff: Kohlenstoffstahl

*Schrauben mit Teilgewinde > 50 mm Länge mit Schaftrippen

fischer Power-Fast und Holzbauschrauben	Anhang A2 der Europäische Technischen Zulassung ETA-11/0027
Abmessungen und Werkstoff	

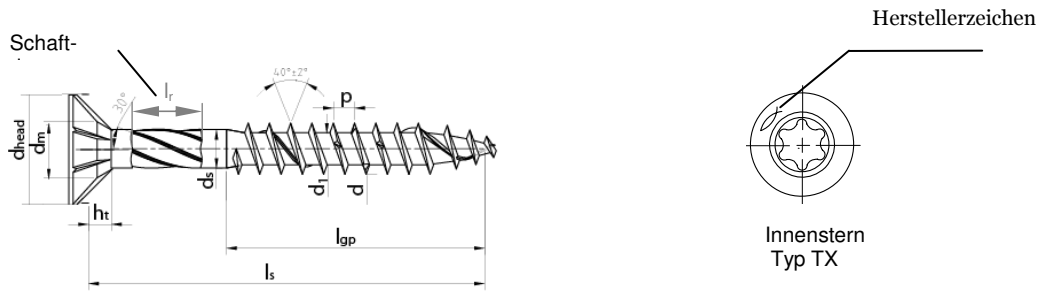

Power-Fast Holzbauschraube (Senkkopf) mit Teilgewinde						
Gewinde-durchmesser		6,0	8,0	10,0	12,0	
d	Gewindenenn-durchmesser	6,15	8,15	10,15	12,15	
	Zulässige Abweichung	-0,4	-0,4	-0,5	-0,6	
d ₁	Kerndurchmesser	4,00	5,40	6,40	7,60	
	Zulässige Abweichung			-0,2		
d _{head}	Kopfdurchmesser	12,10	14,80	18,60	22,60	
	Zulässige Abweichung			-0,6		
d _s	Schaftdurchmesser	4,30	5,90	7,10	8,30	
	Zulässige Abweichung			-0,15		
h _t	Kopfhöhe	3,40	6,50	8,00	10,80	
	Gewindesteigung	3,00-4,50	6,00	7,50	7,50	
p	Zulässige Abweichung			-0,1		
	Länge der Schafttrippen			13,00		
l _r *	Zulässige Abweichung			-2,0		
	Stern Typ TX	30	30	40	50	
Nenngröße	l _s	l _{gp} = Teilgewinde Toleranz: ± 2,0				
		min	max	l _{gf}	l _{gp}	l _{gp}
60	58,50	61,50	36			
80	78,50	81,50	50	50	52	
90	88,25	91,75	60	50		
100	98,25	101,75	60	50	52	
120	118,25	121,75	70	75	80	
140	138	142	70	75	80	
160	158	162	70	75	80	
180	178	182	70	75	100	
200	198	202	70	100	100	
220	218	222	70	100	100	
240	238	262	70	100	100	
260	258	262	70	100	100	
280	278	282	70	100	115	
300	398	302	70	100	115	
320	317	323		100	115	
330	327	333			115	
340	337	343		100	115	
350	347	353			145	
360	357	363		100	115	
380	377	383		100	115	
400	397	403		100	115	
450	447	453		100	115	
500	497	503		100	115	
550	547	553			145	
600	597	603			145	

Zwischenlängen bei l_s sind möglich

Alle Maße in mm

Zulässige Oberflächenbehandlungen: galvanisch verzinkt, gelb passiviert; galvanisch verzinkt, blau passiviert; Bonuszink
Werkstoff: Kohlenstoffstahl

fischer Power-Fast und Holzbauschrauben	Anhang A3 der Europäischen Technischen Zulassung ETA-11/0027
Abmessungen und Werkstoff	

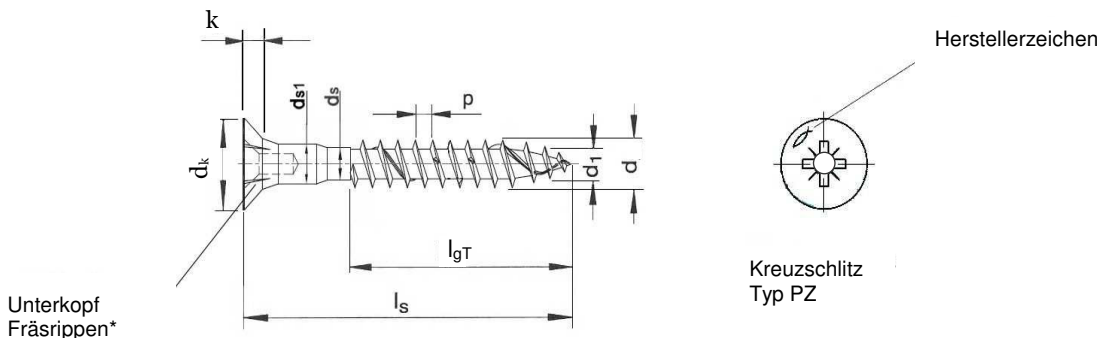

* optional

Selbstbohrende Schraube (Senkkopf mit Kopflochbohrung) mit Voll- oder Teilgewinde																	
Nenndurchmesser		4,0	4,5	5,0	6,0												
d	Gewindegröße	4,15	4,65	5,15	6,15												
	zul. Abw.	-0,40															
d ₁	Kerndurchmesser	2,50	2,70	3,10	3,80												
	zul. Abw.	-0,25 / +0,10		-0,30 / +0,10													
d _k	Kopfdurchmesser	8,00	8,80	9,70	11,60												
	zul. Abw.	-0,50 / +0,10															
d _s	Schaftdurchmesser	2,90	3,25	3,55	4,30												
	zul. Abw.	-0,30 / +0,10															
k	Kopfhöhe	2,50	2,70	3,00	3,40												
p	Gewindesteigung	2,00	2,20	2,50	3,00												
	zul. Abw.	±10%															
d _{s1}	Schaftdurchmesser	3,70	3,85	4,05	4,20												
	zul. Abw.	-0,10															
Kreuzschlitzgröße Typ PZ		2				3											
Nennmaß		l _s		Standardgewindelängen								l _{gV} = Vollgewinde		l _{gT} = Teilgewinde		Toleranz: ± 2,0	
		min	max	l _{gV}	l _{gT}	l _{gV}	l _{gT}	l _{gV}	l _{gT}	l _{gV}	l _{gT}	l _{gV}	l _{gT}				
25		23,75	26,25		17,5												
27		25,75	28,25		19,5												
30		28,75	31,25		22,5		19										
35		33,50	36,50		27,5		24										
40		38,50	41,50		32,5		29		29								
45		43,50	46,50		37,5		34		34								
50		48,50	51,50		42,5		39		39		41						
55		53,50	56,50		47,5		44		44		46						
60		58,50	61,50		50		49		49		51						
70		68,50	71,50				59		60		60						
80		78,50	81,50				59		60		60						
90		88,25	91,75				59		60		60						
100		98,25	101,75						60		60						

Zwischenlängen bei l_s sind möglich.

Alle Maße in mm

Mögliche Oberflächenbehandlungen: galvanisch verzinkt, blau passiviert.

Werkstoff: Kohlenstoffstahl

fischer Power-Fast und Konstruktionsschrauben	Anhang A4 der Europäischen Technischen Zulassung ETA-11/0027

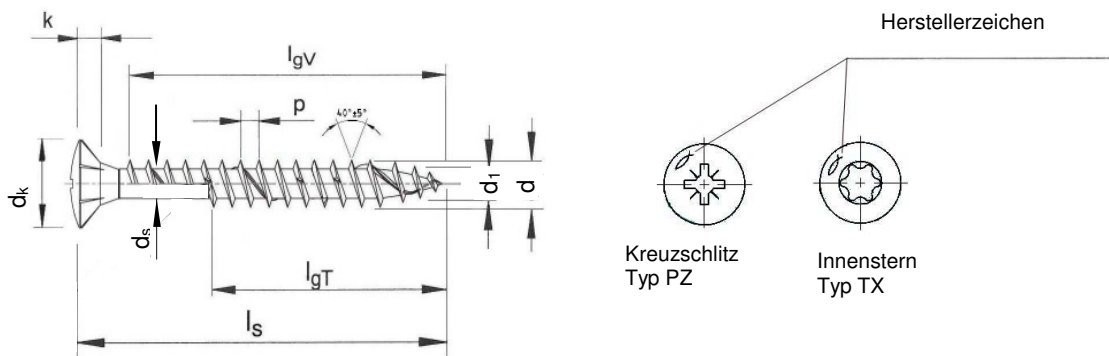

Selbstbohrende Schraube (Linsensenkopf) mit Voll- oder Teilgewinde																	
Nenndurchmesser		3,0	3,5	4,0	4,5	5,0	6,0										
d	Gewindegröße	3,15	3,65	4,15	4,65	5,15	6,15										
	zul. Abw.							-0,40									
d ₁	Kerndurchmesser	2,00	2,20	2,50	2,70	3,10	3,80										
	zul. Abw.	-0,25 / +0,10				-0,30 / +0,10											
d _k	Kopfdurchmesser	6,00	7,00	8,00	8,80	9,70	11,60										
	zul. Abw.							-0,50 / +0,10									
d _s	Schaftdurchmesser	2,25	2,55	2,90	3,25	3,55	4,30										
	zul. Abw.							-0,30 / +0,10									
k	Kopfhöhe	1,90	2,10	2,50	2,70	3,00	3,40										
p	Gewindesteigung	1,50	1,80	2,00	2,20	2,50	3,00										
	zul. Abw.							±10%									
Innensterngröße TX		10		20			30										
Kreuzschlitzgröße Typ PZ		1		2			3										
Nennmaß		l _s		Standardgewindelängen										Toleranz: ± 2,0			
		min	max	l _{gv}	l _{gt}	l _{gv}	l _{gt}	l _{gv}	l _{gt}	l _{gv}	l _{gt}	l _{gv}	l _{gt}	l _{gv}	l _{gt}	l _{gv}	l _{gt}
20		18,95	21,05	16		16		16									
25		23,75	26,25	21		21	18	21	18	20							
30		28,75	31,25	26	18	26	18	26	18	25	18	24					
35		33,50	36,50	31	24	31	24	31	24	30	24	29	24	28			
40		38,50	41,50		24	36	24	36	24	35	24	34	24	33			
45		43,50	46,50		30		30	41	30	40	30	39	30	38			
50		48,50	51,50			30	46	30	45	30	44	30	43				
55		53,50	56,50					36		36		36	36				
60		58,50	61,50					36		36		36	53				
70		68,50	71,50					42		42		42	63				
80		78,50	81,50					50		50		50	73				

Zwischenlängen bei l_s sind möglich.

Alle Maße in mm

Mögliche Oberflächenbehandlungen: galvanisch verzinkt, gelb passiviert; galvanisch verzinkt, blau passiviert; Bonuszink; brüniert; vernickelt; vermessingt.

Werkstoff: Kohlenstoffstahl

fischer Power-Fast und Holzbauschrauben Abmessungen und Werkstoff	Anhang A5 der Europäische Technischen Zulassung ETA-11/0027
---	--

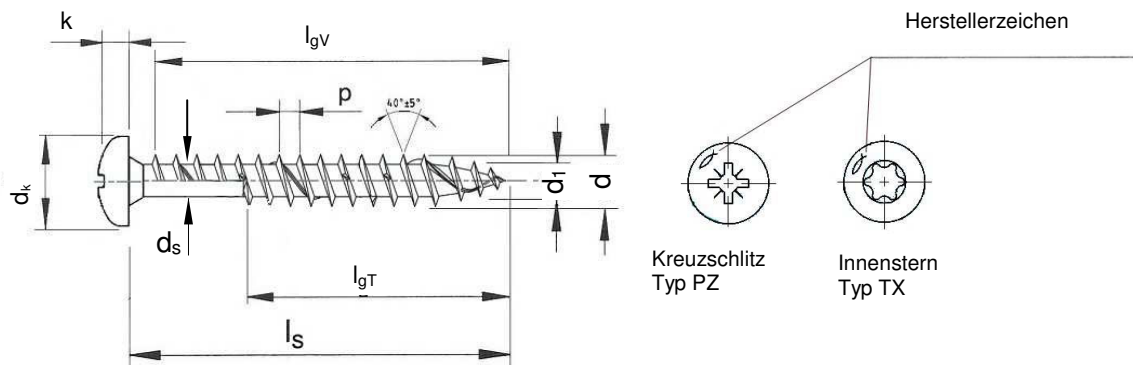

Selbstbohrende Schraube (Pan head) mit Voll- oder Teilgewinde

Nenndurchmesser		3,0	3,5	4,0	4,5	5,0	6,0														
d	Gewindegröße	3,15	3,65	4,15	4,65	5,15	6,15														
	zul. Abw.							-0,40													
d ₁	Kerndurchmesser	2,00	2,20	2,50	2,70	3,10	3,80														
	zul. Abw.	-0,25 / +0,10				-0,30 / +0,10															
d _k	Kopfdurchmesser	6,00	7,00	8,00	9,00	9,90	11,90														
	zul. Abw.	-0,50 / +0,10																			
d _s	Schaftdurchmesser	2,25	2,55	2,90	3,25	3,55	4,30														
	zul. Abw.	-0,30 / +0,10																			
k	Kopfhöhe	2,30	2,50	2,90	3,10	3,40	3,40														
p	Gewindesteigung	1,50	1,80	2,00	2,20	2,50	3,00														
	zul. Abw.	±10%																			
Innensterngröße TX		10			20			30													
Kreuzschlitzgröße Typ PZ		1	2				3														
Nennmaß		l _s min max		Standardgewindelängen										l _{gv} = Vollgewinde		l _{gt} = Teilgewinde		Toleranz: ± 2,0			
				l _{gv}	l _{gt}	l _{gv}	l _{gt}	l _{gv}	l _{gt}	l _{gv}	l _{gt}	l _{gv}	l _{gt}	l _{gv}	l _{gt}	l _{gv}	l _{gt}				
20		18,95	21,05	16		16															
25		23,75	26,25	21		21	18	20	18	20											
30		28,75	31,25	26	18	26	18	25	18	25	18	24									
35		33,50	36,50	31	24	31	24	30	24	30	24	29	24	28							
40		38,50	41,50		24	36	24	35	24	35	24	34	24	33	24						
45		43,50	46,50		30		30	40	30	40	30	39	30	38							
50		48,50	51,50			30	45	30	45	30	44	36	43	30							
55		53,50	56,50					36		36		36									
60		58,50	61,50					36		36		42	53	36							
70		68,50	71,50					42		42		50	63	42							
80		78,50	81,50					50		50		50	73	50							
90		88,25	91,75									60		60							
100		98,25	101,75									60		70							

Zwischenlängen bei l_s sind möglich.

Alle Maße in mm

Mögliche Oberflächenbehandlungen: galvanisch verzinkt, gelb passiviert; galvanisch verzinkt, blau passiviert; Bonuszink; brüniert; vernickelt; vermessingt.

Werkstoff: Kohlenstoffstahl

fischer Power-Fast und Holzbauschrauben Abmessungen und Werkstoff	Anhang A6 der Europäischen Technischen Zulassung ETA-11/0027

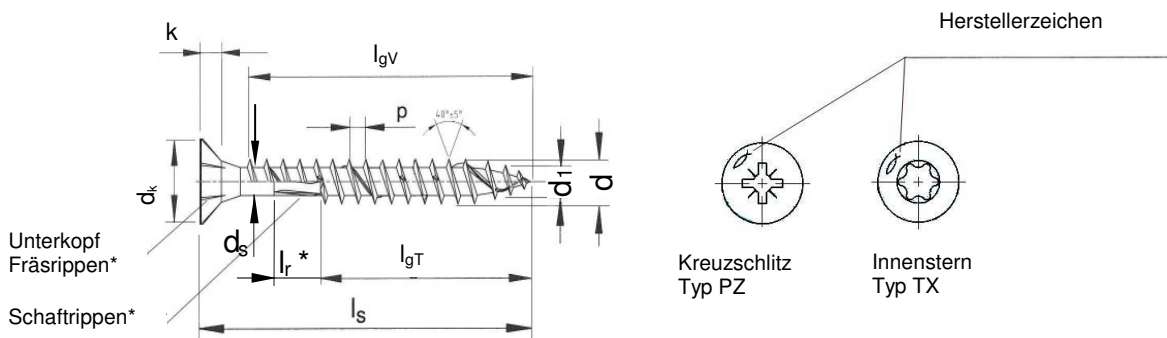

* optional

Selbstbohrende Schraube (**Senkkopf**) mit Voll- oder Teilgewinde

Nenndurchmesser		3,0	3,5	4,0	4,5	5,0	6,0	8,0									
d	Gewindegröße	3,15	3,65	4,15	4,65	5,15	6,15	8,15									
	zul. Abw.	-0,40															
d ₁	Kerndurchmesser	2,00	2,20	2,50	2,70	3,10	3,80	5,40									
	zul. Abw.	-0,25 / +0,10			-0,30 / +0,10		-0,2										
d _k	Kopfdurchmesser	6,00	7,00	8,00	8,80	9,70	11,60	14,80									
	zul. Abw.	-0,50 / +0,10						-0,8									
d _s	Schaftdurchmesser	2,25	2,55	2,90	3,25	3,55	4,30	5,90									
	zul. Abw.	-0,30 / +0,10						-0,15									
k	Kopfhöhe	1,90	2,10	2,50	2,70	3,00	3,40	6,50									
p	Gewindesteigung	1,50	1,80	2,00	2,20	2,50	3,00	6,00									
	zul. Abw.	±10%															
l _r *	Schaftrippenlänge	3,75	4,25	4,75	5,5	6,0	7,0	13,00									
	zul. Abw.	±0,75			±1,0				-2,0								
Innensterngröße TX		10			20			30	40								
Kreuzschlitzgröße Typ PZ		1	2				3	-									
Nennmaß	l _s	Standardgewindelängen														Toleranz: ± 2,0	
		l _{gv} = Vollgewinde		l _{gT} = Teilgewinde													
20	18,95	21,05	16		16												
25	23,75	26,25	21		21	18	20	18	20								
30	28,75	31,25	26	18	26	18	25	18	25	18	24						
35	33,50	36,50	31	24	31	24	30	24	30	24	29	24	28				
40	38,50	41,50	36	24	36	24	35	24	35	24	34	24	33	24			
45	43,50	46,50	41	30	41	30	40	30	40	30	39	30	38				
50	48,50	51,50			46	30	45	30	45	30	44	30	43	30			
55	53,50	56,50					50	36	50	36	49	36	48				
60	58,50	61,50						36		36		36	53	36			
70	68,50	71,50						42		42		42	63	42			
80	78,50	81,50						50		50		50	73	50	50		
90	88,25	91,75										60		60	50		
100	98,25	101,75										60		60	50		
110	108,25	111,75										70		70			
120	118,25	121,75										70		70	75		
130	128,00	132,00												70			
140	138,00	142,00												70	75		
150	148,00	152,00												70			
160	158,00	162,00												70	75		
180	178,00	182,00												70	75		
bis																	
300	298,00	302,00												70	100		
320	318,00	322,00													100		
340	338,00	342,00													100		
360	358,00	362,00													100		
380	378,00	382,00													100		
400	398,00	402,00													100		
450	448,00	452,00													100		
500	498,00	502,00													100		

Zwischenlängen bei l_s sind möglich.

Alle Maße in mm

Werkstoff: Edelstahl

fischer Power-Fast und Holzbauschrauben Abmessungen und Werkstoff	Anhang A7 der Europäische Technischen Zulassung ETA-11/0027

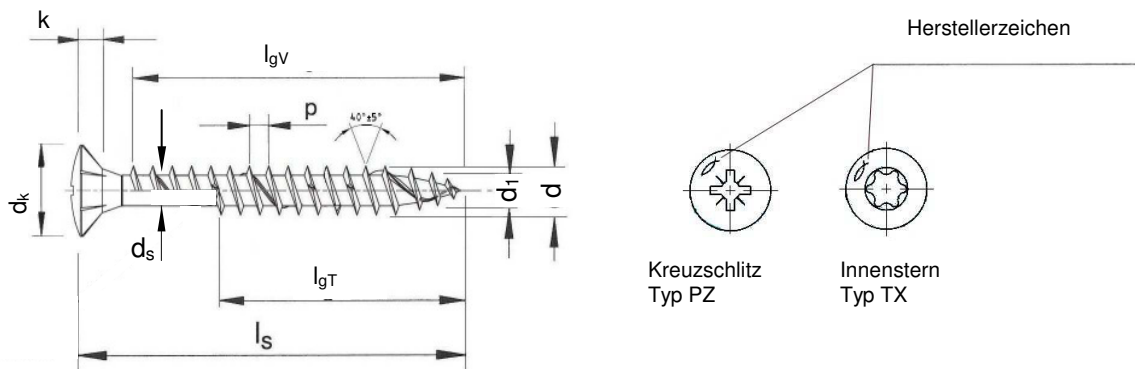

Selbstbohrende Schraube (Linsensenkopf) mit Voll- oder Teilgewinde													
Nenndurchmesser		3,0	3,5	4,0	4,5	5,0	6,0						
d	Gewindegröße	3,15	3,65	4,15	4,65	5,15	6,15						
	zul. Abw.	-0,40											
d ₁	Kerndurchmesser	2,00	2,20	2,50	2,70	3,10	3,80						
	zul. Abw.	-0,25 / +0,10				-0,30 / +0,10							
d _k	Kopfdurchmesser	6,00	7,00	8,00	8,80	9,70	11,60						
	zul. Abw.	-0,50 / +0,10											
d _s	Schaftdurchmesser	2,25	2,55	2,90	3,25	3,55	4,30						
	zul. Abw.	-0,30 / +0,10											
k	Kopfhöhe	1,90	2,10	2,50	2,70	3,00	3,40						
p	Gewindesteigung	1,50	1,80	2,00	2,20	2,50	3,00						
	zul. Abw.	±10%											
Innensterngröße TX		10			20			30					
Kreuzschlitzgröße Typ PZ		1	2				3						
Nennmaß		Standardgewindelängen l _{gv} = Vollgewinde l _{gT} = Teilgewinde Toleranz: ± 2,0											
	l _s	min	max	l _{gv}	l _{gT}	l _{gv}	l _{gT}	l _{gv}	l _{gT}	l _{gv}	l _{gT}	l _{gv}	l _{gT}
20		18,95	21,05	16		16		16					
25		23,75	26,25	21		21	18	21	18	20			
30		28,75	31,25	26	18	26	18	26	18	25	18	24	
35		33,50	36,50	31	24	31	24	31	24	30	24	29	24
40		38,50	41,50		24	36	24	36	24	35	24	34	24
45		43,50	46,50		30		30	41	30	40	30	39	30
50		48,50	51,50			30	46	30	45	30	44	30	43
55		53,50	56,50					36		36		36	
60		58,50	61,50					36		36		36	53
70		68,50	71,50					42		42		42	63
80		78,50	81,50					50		50		50	73

Zwischenlängen bei l_s sind möglich.
Werkstoff: Edelstahl

Alle Maße in mm

fischer Power-Fast und Holzbauschrauben Abmessungen und Werkstoff	Anhang A8 der Europäischen Technischen Zulassung ETA-11/0027
---	---

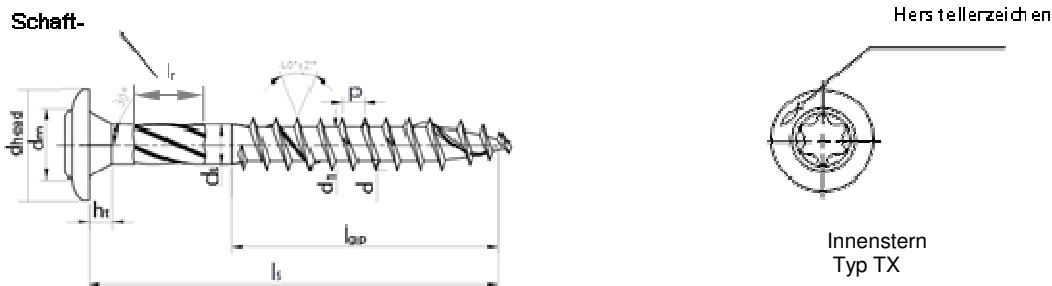

Power-Fast Holzbauschraube (Tellerkopfschraube) mit Voll- oder Teilgewinde									
Gewinde-durchmesser		6,0	8,0	10,0	12,00				
d	Gewindenennendurchmesser	6,15	8,15	10,15	12,15				
	Zulässige Abweichung	-0,4							
d ₁	Kerndurchmesser	4,00	5,40	6,40	7,60				
	Zulässige Abweichung	-0,2							
d _{head}	Kopfdurchmesser	14,50	21,00	27,00	30,00				
	Zulässige Abweichung	-2,0	-1,00	-3,00	-3,00				
d _s	Schaftdurchmesser	4,30	5,90	7,10	8,30				
	Zulässige Abweichung	-0,15							
h _t	Kopfhöhe	2,50	2,60	3,40	4,40				
	Zulässige Abweichung	-0,2							
p	Gewindesteigung	3,00-4,50	6,00	7,50	7,50				
	Zulässige Abweichung	-0,1							
l _r	Länge der Schaftrippen	13,00							
	Zulässige Abweichung	-2,0							
Stern Typ TX		30	40	40	50				
Nenngröße	l _s	Normgewindelänge		l _{gf} = Vollgewinde		l _{gp} = Teilgewinde		Toleranz: ± 2,0	
		min	max	l _{gp}	l _{gp}	l _{gp}	l _{gp}		
60	58,50	61,50	36						
80	78,50	81,50	50	50	52				
90	88,25	91,75	60	50					
100	98,25	101,75	60	50	52	60			
120	118,25	121,75	70	75	80	80			
140	138	142	70	75	80	80			
160	158	162	70	75	80	80			
180	178	182	70	75	100	100			
200	198	202	70	100	100	100			
220	218	222	70	100	100	100			
240	238	262	70	100	100	120			
260	258	262	70	100	100	120			
280	278	282	70	100	115	120			
300	398	302	70	100	115	120			
320	317	323		100	115				
330	327	333			115				
340	337	343		100	115				
350	347	353				145			
360	357	363		100	115				
380	377	383		100	115				
400	397	403		100	115	145			
450	447	453		100	115	145			
500	497	503		100	115	145			
550	547	553				145			
600	597	603				145			

Zwischenlängen bei l_s sind möglich

Alle Maße in mm

Mögliche Oberflächenbehandlungen: galvanisch verzinkt, gelb passiviert; galvanisch verzinkt, blau passiviert; Bonuszink

Material: Kohlenstoffstahl

fischer Power-Fast und Holzbauschrauben	Anhang A10 der Europäische Technischen Zulassung ETA-11/0027
Abmessungen und Werkstoff	

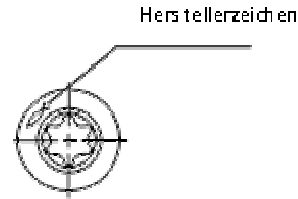
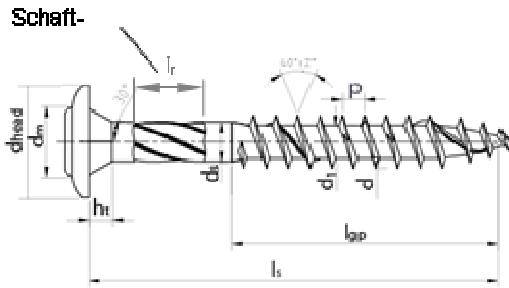

Innenstern
Typ TX

Power-Fast Holzbauschraube (Linsen-Flanschkopfschraube) mit Teilgewinde													
Gewinde-durchmesser		6,0	8,0										
d	Gewindenenn-durchmesser	6,00	8,00										
	Zulässige Abweichung	-0,50 / +0,15											
d1	Kerndurchmesser	4,00	5,40										
	Zulässige Abweichung	-0,35 / +0,15											
dhead	Kopfdurchmesser	13,75	21,00										
	Zulässige Abweichung	+/-0,75	+/-1,00										
ds	Schaftdurchmesser	4,30	5,90										
	Zulässige Abweichung	-0,30 / +0,10											
ht	Kopfhöhe	2,3-2,5	2,5-4,5										
p	Gewindesteigung	4,50	6,00										
	Zulässige Abweichung	±10%											
lr	Länge der Schafttrippen	12,0											
	Zulässige Abweichung	±1,0											
Stern Typ TX		30	40										
Nenngröße	ls	min	max	l _{gp}	Normgewindelänge								
					l _{gp}	l _{gf} = Vollgewinde		l _{gp} = Teilgewinde		Toleranz: ± 2,0			
60	58,50	61,50	36										
80	78,50	81,50	50	50									
90	88,25	91,75	60	50									
100	98,25	101,75	60	50									
120	118,25	121,75	70	75									
140	138	142	70	75									
160	158	162	70	75									
180	178	182	70	75									
200	198	202	70	100									
220	218	222	70	100									
240	238	262	70	100									
260	258	262	70	100									
280	278	282	70	100									
300	398	302	70	100									
320	317	323		100									
330	327	333											
340	337	343		100									
350	347	353											
360	357	363		100									
380	377	383		100									
400	397	403		100									
450	447	453		100									
500	497	503		100									
550	547	553											
600	597	603											

Zwischenlängen bei l_s sind möglich
Werkstoff: Edelstahl

Alle Maße in mm

fischer Power-Fast und Holzbauschrauben Abmessungen und Werkstoff	Anhang A11 der Europäischen Technischen Zulassung ETA-11/0027

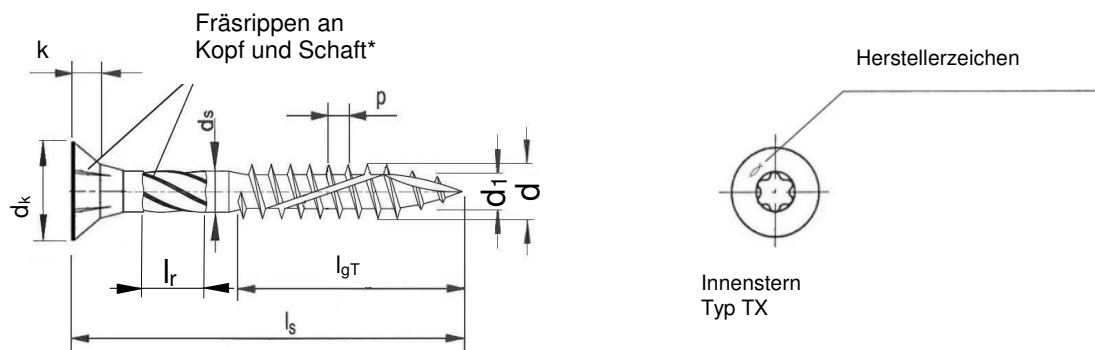

* optional

Selbstbohrende Schraube (Holzbauschraube Senkkopf) mit Voll- oder Teilgewinde												
Nenndurchmesser		8,0	10,0									
d	Gewindegröße	8,00	10,00									
	zul. Abw.	-0,50 / +0,15										
d ₁	Kerndurchmesser	5,40	6,35									
	zul. Abw.	-0,35 / +0,15										
d _k	Kopfdurchmesser	14,80	18,60									
	zul. Abw.	-0,80 / -0,60										
d _s	Schaftdurchmesser	5,90	7,10									
	zul. Abw.	-0,30 / +0,10										
k	Kopfhöhe	6,0-7,0	7,5-8,5									
p	Gewindesteigung	5,20	5,60									
	zul. Abw.	±10%										
l _r	Schaftrippenlänge	12,0										
	zul. Abw.	±1,0										
Innensterngröße TX		40										
l _s			Standardgewindelängen l _{qV} = Vollgewinde l _{qT} = Teilgewinde Toleranz: ± 2,0									
Nennmaß	min	max	l _{qV}	l _{qT}								
80	78,50	81,50	50	52								
90	88,25	91,75	50	52								
100	98,25	101,75	50	52								
110	108,25	111,75	75	80								
120	118,25	121,75	75	80								
130	128,00	132,00	75	80								
140	138,00	142,00	75	80								
150	148,00	152,00	75	80								
160	158,00	162,00	75	80								
180	178,00	182,00	75	80								
bis												
400	398,00	402,00	75	80								

Zwischenlängen bei l_s sind möglich. Alle Maße in mm
 Mögliche Oberflächenbehandlungen: galvanisch verzinkt gelb passiviert; galvanisch verzinkt, blau passiviert.
 Werkstoff: Kohlenstoffstahl

fischer Power-Fast und Holzbauschrauben Abmessungen und Werkstoff	Anhang A12 der Europäische Technischen Zulassung ETA-11/0027
---	---

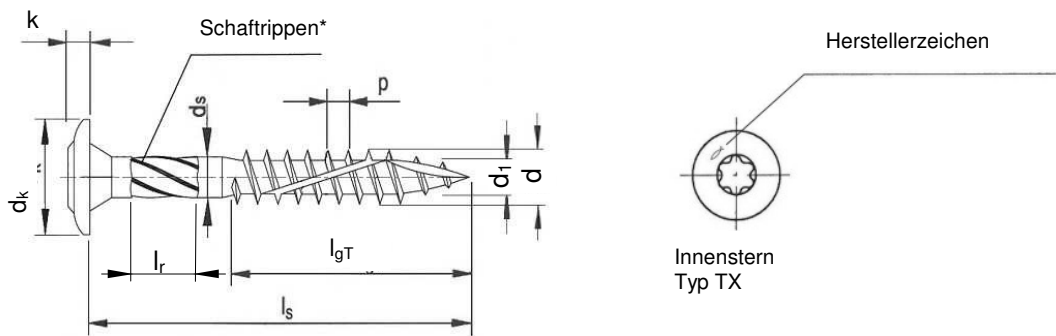

* optional

Selbstbohrende Schraube (Holzbauschraube Tellerkopf) mit Voll- oder Teilgewinde												
Nenndurchmesser		8,0	10,0									
d	Gewindegröße	8,00	10,00									
	zul. Abw.	-0,50 / +0,15										
d1	Kerndurchmesser	5,40	6,35									
	zul. Abw.	-0,35 / +0,15										
dk	Kopfdurchmesser	21,00	27,00									
	zul. Abw.	+/-1,00	-3,00									
ds	Schaftdurchmesser	5,90	7,10									
	zul. Abw.	-0,30 / +0,10										
k	Kopfhöhe	2,5-4,5	3,7-5,7									
p	Gewindesteigung	5,20	5,60									
	zul. Abw.	±10%										
lr	Schaftrippenlänge	12,0										
	zul. Abw.	±1,0										
Innensterngröße TX		40										
ls			Standardgewindelängen				lgv = Vollgewinde		lgt = Teilgewinde		Toleranz: ± 2,0	
Nennmaß	min	max	lgv	lgt	lgv	lgt						
80	78,50	81,50	50	52								
90	88,25	91,75	50	52								
100	98,25	101,75	50	52								
110	108,25	111,75	75	80								
120	118,25	121,75	75	80								
130	128,00	132,00	75	80								
140	138,00	142,00	75	80								
150	148,00	152,00	75	80								
160	158,00	162,00	75	80								
180	178,00	182,00	75	80								
bis												
400	398,00	402,00	75	80								

Zwischenlängen bei ls sind möglich.

Alle Maße in mm

Mögliche Oberflächenbehandlungen: galvanisch verzinkt, gelb passiviert; galvanisch verzinkt, blau passiviert.

Werkstoff: Kohlenstoffstahl

fischer Power-Fast und Holzbauschrauben	Anhang A13 der Europäisch Technischen Zulassung ETA-11/0027
Abmessungen und Werkstoff	

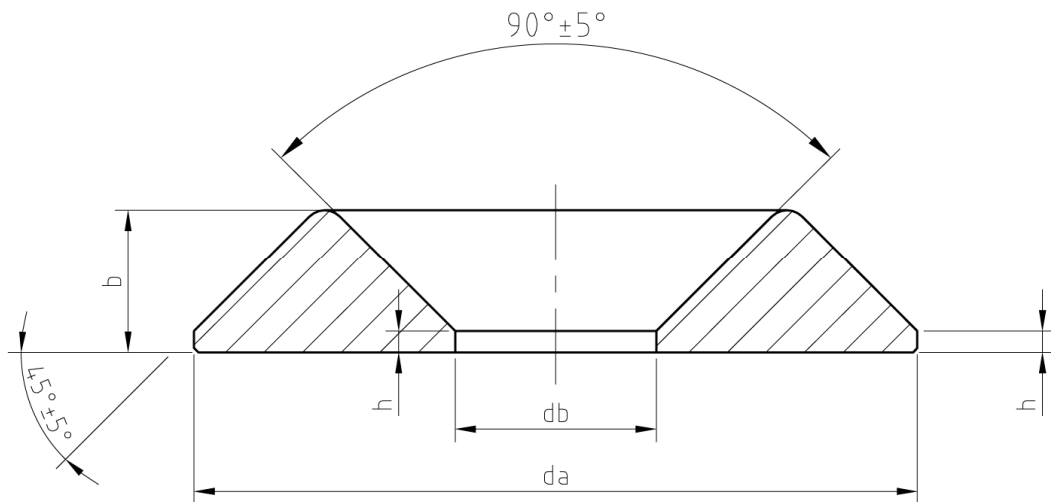

Unterlegscheibe für Power-Fast- und FCS-Schrauben											
Größe		Typ 1				Typ 2					
		6	8	10	12	6	8	10			
d _b	Innendurchmesser	6,7	8,7	11,2	13,2	6,7	8,7	11,2			
	Zulässige Abweichung	-0,4	-0,4	-0,4	-0,4	-0,4	-0,4	-0,4			
d _a	Außendurchmesser	21	30	35	43	21	25,5	30,5			
	Zulässige Abweichung	±2,0									
b	Höhe	4,7	5,2	6,2	8,3	4,7	5,2	6,2			
	Zulässige Abweichung	-0,4	-0,4	-0,4	-0,4	-0,4	-0,4	-0,4			
h	Höhe	1,5	1,8	2,0	2,2	1,5	1,8	2,0			
	Zulässige Abweichung	-0,15	-0,15	-0,15	-0,15	-0,15	-0,15	-0,15			

Alle Maße in mm

Mögliche Oberflächenbehandlungen: galvanisch verzinkt, gelb passiviert; galvanisch verzinkt, blau passiviert.

Werkstoff: Kohlenstoffstahl

fischer Power-Fast und Holzbauschrauben	Anhang A14 der Europäischen Technischen Zulassung ETA-11/0027
Zubehör	

Anhang B1 Befestigung von Aufdach-Dämmsystemen

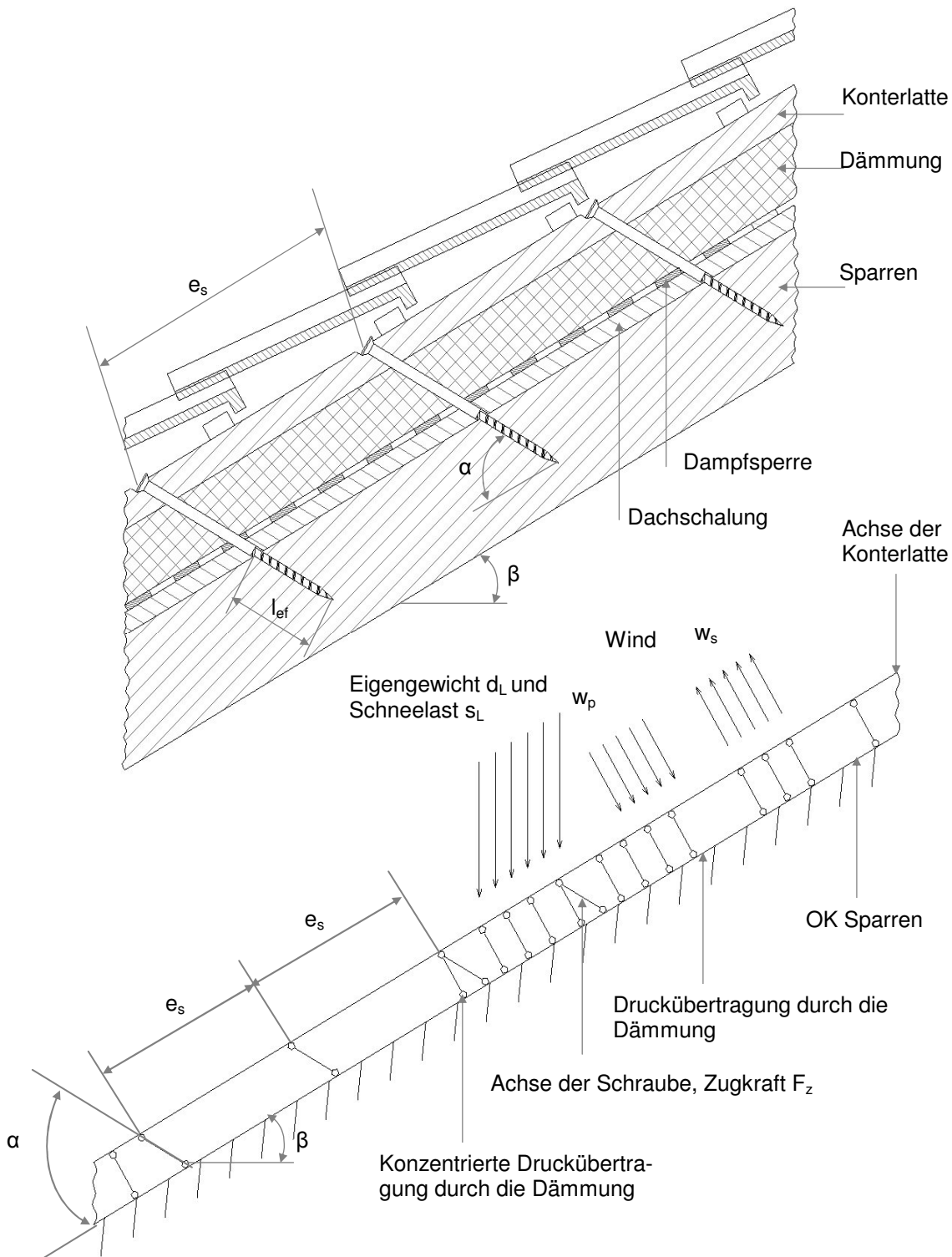

- | | | | |
|-----------|------------------|------------|---|
| w_s = | Windsog | w_p = | Winddruck |
| e_s = | Schraubenabstand | l_{ef} = | Gewindeeinschraubtiefe im Sparren |
| β = | Dachneigung | α = | Winkel zwischen Schrauben- und Sparrenachse |

fischer Power-Fast und Holzbauschrauben	Anhang B1
Befestigung von Aufdach-Dämmsystemen	der Europäische Technischen Zulassung ETA-11/0027

Anhang B2 Befestigung von Aufdach-Dämmsystemen

Punktlasten F_b senkrecht zu den Latten

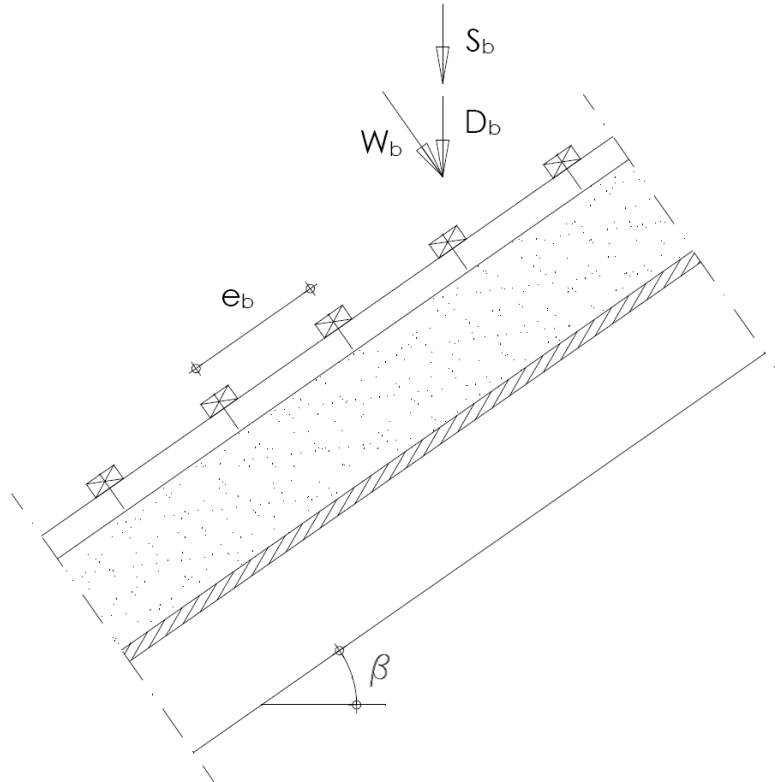

$$D_b = d \cdot e_b \cdot e_r$$

$$S_b = s \cdot e_b \cdot e_r \cdot \cos \beta$$

$$W_b = w_p \cdot e_b \cdot e_r$$

$$F_b = W_b + (D_b + S_b) \cdot \cos \beta$$

Darin sind

D_b = Punktlast aus Eigenlast

S_b = Punktlast aus Schneelast

W_b = Punktlast senkrecht zur Latte aus Windlast (Druck)

e_b = Lattenabstand

e_r = Sparrenabstand (=Konterlattenabstand)

s = Schneelast pro m^2 Grundfläche

w_p = Winddruck auf Dachfläche

d = Eigenlast pro m^2 Dachfläche

β = Dachneigung

fischer Power-Fast und Holzbauschrauben	Anhang B2-1
Befestigung von Aufdach-Dämmsystemen	der Europäischen Technischen Zulassung ETA-11/0027

Punktlasten F_s senkrecht zu den Latten durch die Schrauben

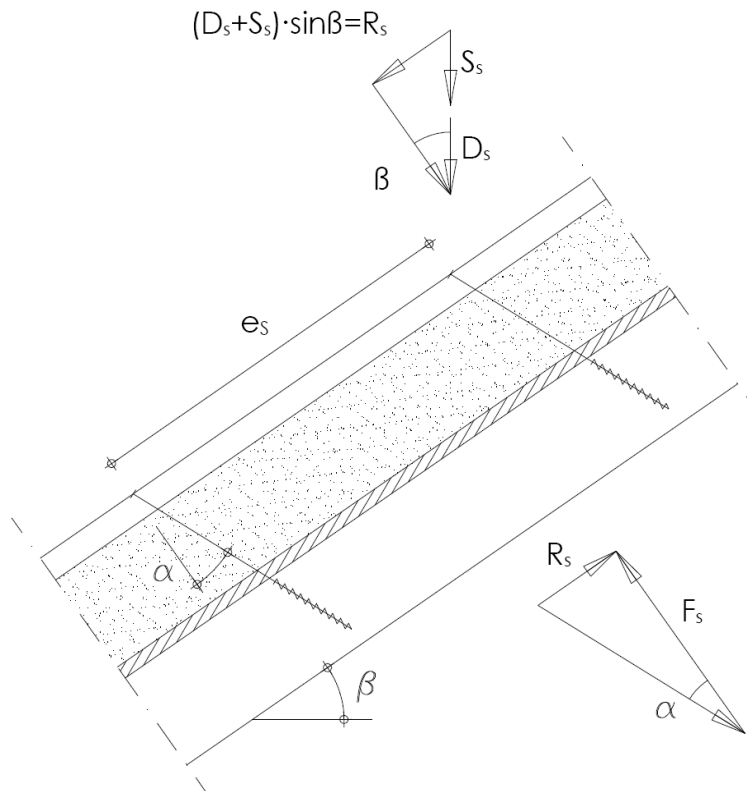

$$D_s = d \cdot e_s \cdot e_r$$

$$S_s = s \cdot e_s \cdot e_r \cdot \cos \beta$$

$$R_s = (D_s + S_s) \cdot \sin \beta$$

$$F_s = R_s / \tan \alpha$$

Darin sind

- D_s = Punktlast aus Eigenlast
- S_s = Punktlast aus Schneelast
- R_s = Schublast des Dachs aus Eigenlast und Schneelast
- e_s = Schraubenabstand
- e_r = Sparrenabstand (=Kontrelattenabstand)
- α = Winkel zwischen Schraubenachse und der Senkrechten zur Sparrenachse

fischer Power-Fast und Holzbauschrauben	Anhang B2-2
Befestigung von Aufdach-Dämmsystemen	der Europäischen Technischen Zulassung ETA-11/0027

Bemessung der Latten

Die Biegespannung errechnet sich aus:

$$M = \frac{(F_b + F_s) \cdot \ell_{\text{char}}}{4}$$

Darin sind:

$$\ell_{\text{char}} = \text{charakteristische Länge } \ell_{\text{char}} = \sqrt[4]{\frac{4 \cdot EI}{w_{\text{ef}} \cdot K}}$$

EI = Biegesteifigkeit der Konterlatte

K = Bettungsziffer

w_{ef} = Effektive Breite des Wärmedämmstoffs

F_b = Punktlasten senkrecht zur Latte

F_s = Punktlasten senkrecht zur Latte, Belastung im Schraubenkopfbereich

Die Bettungsziffer K kann aus dem Elastizitätsmoduls E_{HI} und der Dicke t_{HI} der Wärmedämmung ermittelt werden, sofern die effektive Breite w_{ef} der Wärmedämmung unter Druck bekannt ist. Aufgrund der Lastausbreitung in der Wärmedämmung ist die effektive Breite w_{ef} größer als die Breite der Latte bzw. des Sparrens. Für weitere Berechnungen kann die effektive Breite w_{ef} der Wärmedämmung wie folgt bestimmt werden:

$$w_{\text{ef}} = w + t_{\text{HI}} / 2$$

mit

w = Minimum aus der Breite der Latte bzw. des Sparrens

t_{HI} = Dicke der Wärmedämmung

$$K = \frac{E_{\text{HI}}}{t_{\text{HI}}}$$

Folgende Bedingung muss dabei erfüllt werden:

$$\frac{\sigma_{\text{m,d}}}{f_{\text{m,d}}} = \frac{M_{\text{d}}}{W \cdot f_{\text{m,d}}} \leq 1$$

Bei Berechnung des Widerstandsmoments W ist der Nettoquerschnitt zu berücksichtigen.

Die Beanspruchung aus Schub ist wie folgt zu berechnen:

$$V = \frac{(F_b + F_s)}{2}$$

Folgende Bedingung muss dabei erfüllt werden:

$$\frac{\tau_{\text{d}}}{f_{\text{v,d}}} = \frac{1,5 \cdot V_{\text{d}}}{A \cdot f_{\text{v,d}}} \leq 1$$

Bei Berechnung der Querschnittfläche ist der Nettoquerschnitt zu berücksichtigen.

Bemessung der Wärmedämmung

Die Druckspannung in der Wärmedämmung ist wie folgt zu berechnen:

$$\sigma = \frac{1,5 \cdot F_b + F_s}{2 \cdot \ell_{\text{char}} \cdot w}$$

Der Bemessungswert der Druckspannung soll nicht größer als 110 % der Druckspannung bei 10 % Stauchung sein, berechnet nach EN 826.

fischer Power-Fast und Holzbauschrauben	Anhang B2-3 der Europäischen Technischen Zulassung ETA-11/0027
Befestigung von Aufdach-Dämmsystemen	

Bemessung der Schrauben

Die Schrauben werden vorwiegend in Richtung der Schraubenachse beansprucht. Die axiale Zugkraft in der Schraube kann aus den Schubbeanspruchungen des Daches R_s berechnet werden.

$$T_s = \frac{R_s}{\cos \alpha}$$

Die Tragfähigkeit der in Achsrichtung beanspruchten Schrauben ist das Minimum aus den Bemessungswerten der axialen Tragfähigkeit auf Herausziehen des Schraubengewindes, der Kopfdurchziehtragfähigkeit der Schraube und der Zugtragfähigkeit der Schraube.

Um die Verformung des Schraubenkopfes bei einer Dicke der Wärmedämmung von über 220 mm bzw. einer Druckfestigkeit der Wärmedämmung unter $0,12 \text{ N/mm}^2$ zu begrenzen, ist die axiale Tragfähigkeit der Schrauben auf Herausziehen mit den Faktoren k_1 und k_2 abzumindern:

$$F_{ax,\alpha,Rd} = \min \left\{ \begin{array}{l} k_{ax} \cdot f_{ax,d} \cdot d \cdot l_{ef} \cdot k_1 \cdot k_2 \left(\frac{\rho_k}{350} \right)^{0,8} \\ f_{head,d} \cdot d_h^2 \cdot \left(\frac{\rho_k}{350} \right)^{0,8} \end{array} \right.$$

mit:

$f_{ax,d}$	Bemessungswert der Ausziehtragfähigkeit des Gewindeteils der Schraube
d	Gewindeaußendurchmesser der Schraube
l_{ef}	Einbindetiefe des Gewindeteils der Schraube im Sparren, $l_{ef} \geq 40 \text{ mm}$
α	Winkel zwischen Faserrichtung und Schraubenachse ($\alpha \geq 30^\circ$)
ρ_k	Charakteristische Rohdichte des Holzbauteils [kg/m^3]
$f_{head,d}$	Bemessungswert der Kopfdurchziehtragfähigkeit der Schraube
d_h	Kopfdurchmesser
k_1	$\min \{1; 220/t_{H1}\}$
k_2	$\min \{1; \sigma_{10\%}/0,12\}$
t_{H1}	Dicke der Wärmedämmung [mm]
$\sigma_{10\%}$	Druckspannung der Wärmedämmung unter 10 % Stauchung [N/mm^2]

Wenn in o.e. Formel die Faktoren k_1 und k_2 erfüllt sind, braucht die Verformung der Latten bei der Bemessung der Tragfähigkeit der Schrauben nicht berücksichtigt werden. Als Alternative zu den Latten können auch Platten mit einer Dicke von 20 mm aus Sperrholz gemäß EN 636 oder Europäischer Technischer Zulassung oder nationalen jeweils am Einbauort geltenden Vorschriften, Spanplatten gemäß EN 312 oder ETA Europäischer Technischer Zulassung oder nationalen, jeweils am Einbauort geltenden Vorschriften, OSB-Platten gemäß EN 300 oder Europäischer Technischer Zulassung oder nationalen, jeweils am Einbauort geltenden Vorschriften sowie Vollholzplatten gemäß EN 13353 oder Europäischer Technischer Zulassung oder nationalen, jeweils am Einbauort geltenden Vorschriften oder aus Brettsperrholz gemäß einer Europäischen Technischen Zulassung verwendet werden.

fischer Power-Fast und Holzbauschrauben	Anhang B2-4
Befestigung von Aufdach-Dämmsystemen	der Europäischen Technischen Zulassung ETA-11/0027

Anhang C Mindestrand und Achsabstände

In Seiten- bzw. Stirnflächen von Bauteilen aus Brettsperrholz eingedrehte axial oder lateral beanspruchte Schrauben

Der Achsabstand, der Abstand zur Stirnfläche senkrecht bzw. in Faserrichtung der Decklage wird, sofern in der technischen Spezifikation (ETA oder hEN) für Brettsperrholz nicht anderslautend vorgegeben, wie folgt ermittelt:

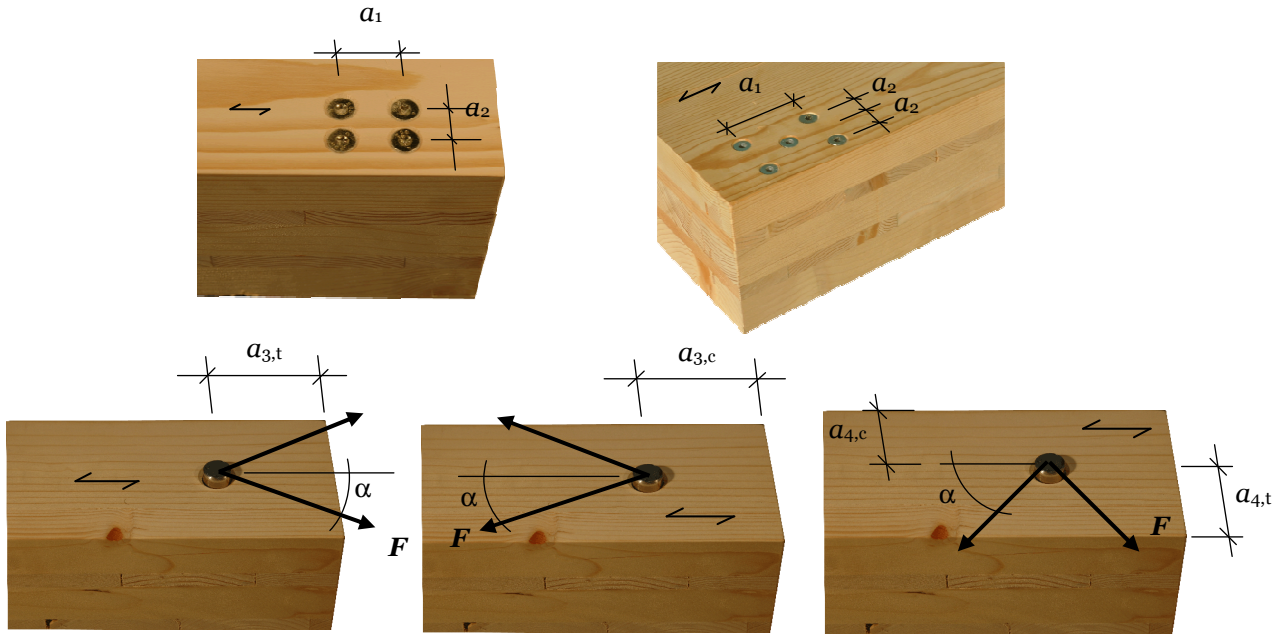

fischer Power-Fast und Holzbauschrauben Mindestrand- und Achsabstände in Brettsperrholz	Anhang C1 der Europäischen Technischen Zulassung ETA-11/0027
---	---

Der Achsabstand, der Abstand zur Stirnfläche Hirnholzende bzw. zur Stirnfläche wird, sofern in der technischen Spezifikation (ETA oder hEN) für Brettsper Holz nicht anderslautend vorgegeben, wie folgt ermittelt:

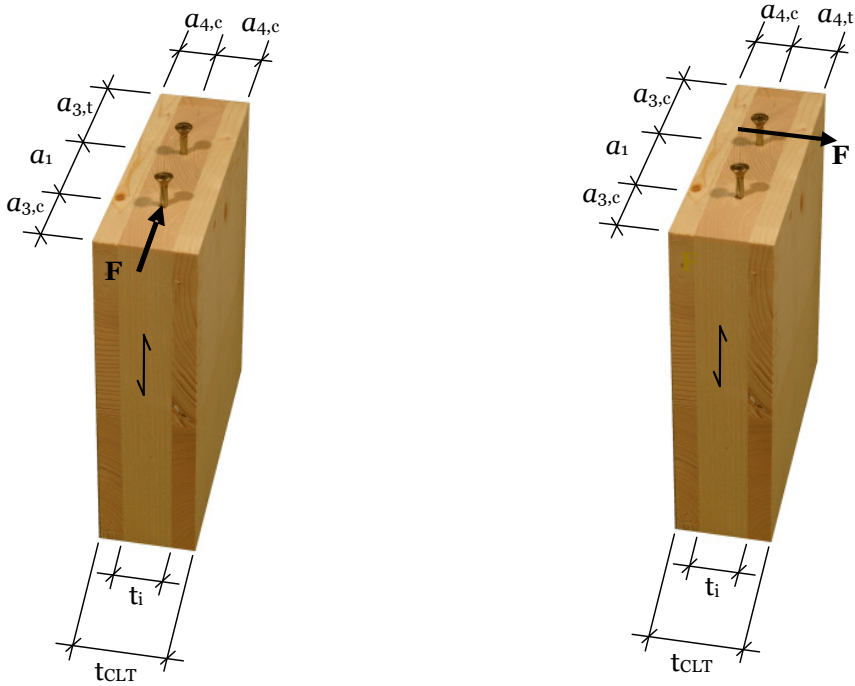

<p>fischer Power-Fast und Holzbauschrauben</p>	<p>Anhang C2</p>
<p>Mindestrand- und Achsabstände in Brettsper Holz</p>	<p>der Europäisch Technischen Zulassung ETA-11/0027</p>